

Features

- TPW3188-TS3R-S: Qualified for Automotive Applications with AEC-Q100 Reliability Test
- Injection Current Control
- Analog Switch Voltage: 1.8 V, 2.5 V, 3.3 V, 5 V
- Low ON-State Resistance:
 - Typical 75 Ω at $V_s = 5\text{ V}$
 - Typical 120 Ω at $V_s = 3.3\text{ V}$
 - Typical 650 Ω at $V_s = 1.8\text{ V}$
- Bandwidth: 250 MHz
- Break-before-Make Switching
- Operation Temperature Range: -40°C to 125°C

Applications

- Body Control Module
- Battery-Powered Systems
- Audio Signal Routing
- Instrumentation

Description

The TPW3188 is a single-pole octal-throw analog switch (SP8T) suitable for analog or digital 8:1 multiplexer/demultiplexer applications. The switch features three digital select inputs (S0, S1, and S2), eight independent inputs/outputs (An), a common input/output (A), and a digital enable input ($\overline{\text{EN}}$). When $\overline{\text{EN}}$ is HIGH, the switches are turned off.

The device is designed on an enhanced process that provides lower power dissipation and gives high switching speeds. These devices can operate equally well as either multiplexers or de-multiplexers and have an input range that extends to the supplies. All channels exhibit break-before-make switching action, preventing momentary shorting when switching channels.

The TPW3188 is available in the TSSOP-16, SOP-16 and QFN2.5X3.5-16L package, and is characterized from -40°C to $+125^\circ\text{C}$.

Typical Application Circuit

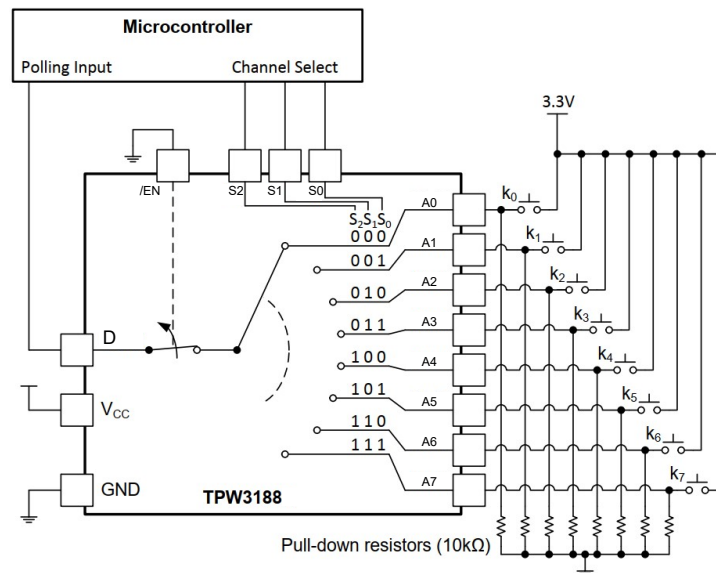

Table of Contents

Features	1
Applications	1
Description	1
Typical Application Circuit	1
Revision History	3
Pin Configuration and Functions	4
Specifications	6
Absolute Maximum Ratings ⁽¹⁾	6
ESD, Electrostatic Discharge Protection.....	6
Recommended Operating Conditions ⁽¹⁾	6
Thermal Information.....	7
Electrical Characteristics.....	8
Typical Performance Characteristics.....	11
Test Circuits and Waveforms.....	14
Detailed Description	17
Overview.....	17
Functional Block Diagram.....	17
Feature Description.....	17
Application and Implementation	18
Application Information	18
Typical Application.....	18
Layout	20
Layout Example.....	20
Tape and Reel Information	21
Package Outline Dimensions	22
TSSOP16.....	22
QFN2.5X3.5-16.....	23
SOP16.....	24
Order Information	25
IMPORTANT NOTICE AND DISCLAIMER	26

Revision History

Date	Revision	Notes
2025-04-01	Rev.A.0	Initial version.

Pin Configuration and Functions

TPW3188
TSSOP16 and SOP16 Package
Top View

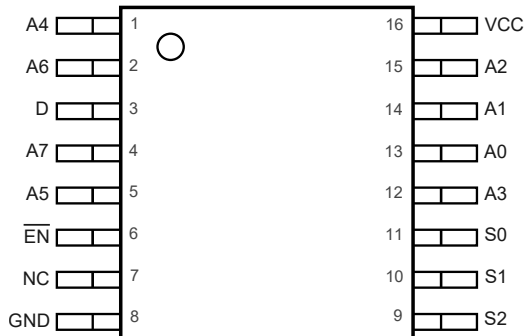

TPW3188
QFN2.5x3.5-16 Package
Top View

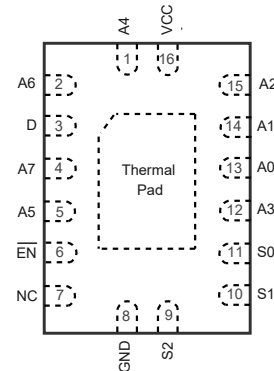

The thermal pad of the QFN package is recommended to be left float or connected to GND.

Table 1. Pin Functions: TPW3188

Pin No.	Name	I/O	Description
1	A4	I/O	Channel 4 input or output
2	A6	I/O	Channel 6 input or output
3	D	I/O	Common input or output
4	A7	I/O	Channel 7 input or output
5	A5	I/O	Channel 5 input or output
6	$\overline{\text{EN}}$	I	Enable switches, active low
7	NC		Not Connected
8	GND		Ground
9	S2	I	Control Input
10	S1	I	Control Input
11	S0	I	Control Input
12	A3	I/O	Channel 3 input or output
13	A0	I/O	Channel 0 input or output
14	A1	I/O	Channel 1 input or output
15	A2	I/O	Channel 2 input or output
16	V _{CC}		Positive Power Input

5-V General Purpose Analog Switch**Table 2. Functional Table**

$\overline{\text{EN}}$, Enable	S2	S1	S0	ON Channel
L	L	L	L	A0
L	L	L	H	A1
L	L	H	L	A2
L	L	H	H	A3
L	H	L	L	A4
L	H	L	H	A5
L	H	H	L	A6
L	H	H	H	A7
H	X	X	X	None

(1) X = Don't care

Specifications

Absolute Maximum Ratings ⁽¹⁾

Parameter		Min	Max	Unit
V _{CC}	Supply Voltage	-0.5	6	V
V _{SD}	Analog Switch Voltage, V _S =Voltage of Ax, V _D =Voltage of D	-0.5	V _{CC} +0.5	V
I _{CC}	Analog Switch Current	-25	+25	mA
I _{CCI}	Digital Input Current, \overline{EN} , S2, S1, S0	-30	+30	mA
V _{DI}	Digital Input Voltage, \overline{EN} , S2, S1, S0	GND	V _{CC} +0.5	V
I _{GND}	Continuous Current through GND	-100	+100	mA
I _{OK}	Current per input into source or drain pins when signal voltage exceeds recommended operating voltage	-50	50	mA
P _{tot}	Total Power Dissipation		500	mW
T _C	Maximum Junction Temperature		150	°C
T _S	Storage Temperature Range	-65	150	°C
T _L	Lead Temperature (Soldering, 10 sec)		260	°C

(1) Stresses beyond those listed under Absolute Maximum Ratings may cause permanent damage to the device. Exposure to any Absolute Maximum Rating condition for extended periods may affect device reliability and lifetime.

ESD, Electrostatic Discharge Protection

Symbol	Parameter	Condition	Minimum Level	Unit
HBM	Human Body Model ESD	ANSI/ESDA/JEDEC JS-001 ⁽¹⁾	±2	kV
CDM	Charged Device Model ESD	ANSI/ESDA/JEDEC JS-002 ⁽²⁾	±1	kV

(1) JEDEC document JEP155 states that 500-V HBM allows safe manufacturing with a standard ESD control process.

(2) JEDEC document JEP157 states that 250-V CDM allows safe manufacturing with a standard ESD control process.

Recommended Operating Conditions ⁽¹⁾

Parameter		Min	Max	Unit
V _{CC}	Supply Voltage, V _{CC}	1.65	5.5	V
V _S or V _D	Analog Switch Voltage, V _S = Voltage of Ax, V _D = Voltage of D	0	V _{CC}	V
V _I	Select Input Voltage	0	V _{CC}	V
T _{R/F}	Input Transition Rise and Fall Rate		100	ns/V
V _{IO}	Switch I/O Port Voltage	0	V _{CC}	V
T _A	Operating Temperature Range	-40	125	°C

(1) Input select must be held HIGH or LOW and it shouldn't float.

Thermal Information

Package Type	θ_{JA}	θ_{JC}	Unit
TSSOP16	150	70	°C/W
SOP16	100	50	°C/W
QFN2.5X3.5-16L	70	69	°C/W

Electrical Characteristics

 All test conditions: $T_A = -40^{\circ}\text{C}$ to 125°C , unless otherwise noted.

Parameter		Test Conditions	VCC	Min	Typ	Max	Units
Analog Switch							
R_{ON}	On-state Switch Resistance	$V_{IS} = 0\text{ V to }V_{CC}$ $I_{OS} = 0.5\text{ mA}$	1.8 V		650	2100	Ω
			2.5 V ⁽¹⁾		230	900	
			3.3 V		120	370	
			5 V ⁽¹⁾		75	270	
ΔR_{ON}	On-state Switch Resistance Matching between Inputs	$V_{IS} = V_{CC} / 2$ $I_{OS} = 0.5\text{ mA}$	1.8 V		10	45	Ω
			2.5 V ⁽¹⁾		3	22	
			3.3 V		2	15	
			5 V ⁽¹⁾		1	14	
$I_{A(OFF)}$	Source Off State Leakage Current	Switch Off $V_{OS} = 0.8 \times V_{CC} / 0.2 \times V_{CC}$ $V_{IS} = 0.2 \times V_{CC} / 0.8 \times V_{CC}$	1.8 V	-800	± 1	800	nA
			2.5 V	-800	± 1	800	
			3.3 V	-800	± 1	800	
			5 V	-800	± 1	800	
$I_{D(OFF)}$	Drain Off State Leakage Current (Common Drain Pin)	Switch Off $V_{OS} = 0.8 \times V_{CC} / 0.2 \times V_{CC}$ $V_{IS} = 0.2 \times V_{CC} / 0.8 \times V_{CC}$	1.8 V	-800	± 1	800	nA
			2.5 V	-800	± 1	800	
			3.3 V	-800	± 1	800	
			5 V	-800	± 1	800	
$I_{D(ON)}$ $I_{A(ON)}$	Channel On State Leakage Current	Switch On $V_{OS} = V_{IS} = 0.8 \times V_{CC}$ or $V_{OS} = V_{IS} = 0.2 \times V_{CC}$	1.8 V	-800	± 1	800	nA
			2.5 V	-800	± 1	800	
			3.3 V	-800	± 1	800	
			5 V	-800	± 1	800	
C_{AOFF}	Source off Capacitance ⁽¹⁾	$V_{IS} = V_{CC} / 2$ $f = 1\text{ MHz}$	1.8 V		4.5	14	pF
			2.5 V		4.5	14	
			3.3 V		4	14	
			5 V		5	14	
C_{DOFF}	Drain off Capacitance ⁽¹⁾	$V_{IS} = V_{CC} / 2$ $f = 1\text{ MHz}$	1.8 V		15	37	pF
			2.5 V		15	37	
			3.3 V		14	37	
			5 V		14	37	
C_{AON} C_{DON}	On Capacitance ⁽¹⁾	$V_{IS} = V_{CC} / 2$ $f = 1\text{ MHz}$	1.8 V ~ 5 V		20	40	pF

5-V General Purpose Analog Switch

Parameter		Test Conditions	VCC	Min	Typ	Max	Units
Power Supply							
I _{CC}	V _{CC} Supply Current	Logic inputs = 0 V or V _{CC}	1.8 V			1.2	uA
			2.5 V			1.5	
			3.3 V			2	
			5 V			3	
Logic Inputs							
V _{IH}	Input Logic High		1.8 V	1.05		5.5	V
			2.5 V	1.12		5.5	
			3.3 V	1.18		5.5	
			5V	1.25		5.5	
V _{IL}	Input Logic Low		1.8V	0		0.6	V
			2.5 V	0		0.65	
			3.3 V	0		0.7	
			5 V	0		0.75	
I _{IH}	Logic High Input Leakage Current	V _{LOGIC} = 1.8 V or V _{CC}	all			1	uA
I _{IL}	Logic Low Input Leakage Current	V _{LOGIC} = 0 V	all	-1			uA
C _{IN}	Logic Input Capacitance	V _{LOGIC} = 0 V, 1.8 V, V _{CC} f = 1 MHz	all		2		pF
Dynamic Characteristics							
Q _{INJ}	Charge Injection	V _{IS} = V _{CC} / 2 R _S = 0 Ω, C _L = 100 pF	1.8 V		8		pC
			2.5 V		8		
			3.3 V		10		
			5 V		15		
O _{ISO}	OFF-Isolation	V _{BIAS} = V _{CC} / 2 V _{IS} = 200 mVpp R _L = 50 Ω, C _L = 5 pF f = 100 kHz	1.8 V		-110		dB
			2.5 V		-110		
			3.3 V		-110		
			5 V		-110		
O _{ISO}	OFF-Isolation	V _{BIAS} = V _{CC} / 2 V _{IS} = 200 mVpp R _L = 50 Ω, C _L = 5 pF f = 1 MHz	1.8 V		-90		dB
			2.5 V		-90		
			3.3 V		-90		
			5 V		-90		
X _{TALK}	Crosstalk	V _{BIAS} = V _{CC} / 2 V _{IS} = 200 mVpp R _L = 50 Ω, C _L = 5 pF f = 100 kHz	1.8 V		-110		dB
			2.5 V		-110		
			3.3 V		-110		
			5 V		-110		
X _{TALK}	Crosstalk	V _{BIAS} = V _{CC} / 2	1.8 V		-90		dB

5-V General Purpose Analog Switch

Parameter		Test Conditions	VCC	Min	Typ	Max	Units
		$V_{IS} = 200 \text{ mVpp}$ $R_L = 50 \Omega, C_L = 5 \text{ pF}$ $f = 1 \text{ MHz}$	2.5 V		-90		
			3.3 V		-90		
			5 V		-90		
BW	Bandwidth	$V_{BIAS} = V_{CC} / 2$ $V_{IS} = 200 \text{ mVpp}$ $R_L = 50 \Omega, C_L = 5 \text{ pF}$	1.8 V		250		MHZ
			2.5V		250		
			3.3 V		250		
			5 V		250		
Switching Characteristics (Timing Characteristics) ⁽¹⁾							
t _{PD}	Propagation Delay	$C_L = 50 \text{ pF}$ Ax to D, D to Ax	1.8 V		15	30	ns
			2.5 V		8	20	
			3.3 V		5	15	
			5 V		4	10	
				$C_L = 15 \text{ pF}$	5 V		1.5
t _{TRAN}	Transition-time between Inputs	$R_L = 10 \text{ k}\Omega, C_L = 50 \text{ pF}$ Sx to D, Sx to Ax	1.8 V		44	103	ns
			2.5 V		30	67	
			3.3 V		23	54	
t _{TRAN}	Transition-time between Inputs	$R_L = 10 \text{ k}\Omega, C_L = 50 \text{ pF}$ Sx to D, Sx to Ax	5 V		18	46	ns
					$R_L = 10 \text{ k}\Omega, C_L = 15 \text{ pF}$	5 V	
t _{ON(EN)}	Turn on-time from Enable	$R_L = 10 \text{ k}\Omega, C_L = 50 \text{ pF}$ EN to D, EN to Ax	1.8 V		39	75	ns
			2.5 V		30	50	
			3.3 V		26	42	
			5 V		24	37	
				$R_L = 10 \text{ k}\Omega, C_L = 15 \text{ pF}$	5 V		22
t _{OFF(EN)}	Turn off Time from Enable	$R_L = 10 \text{ k}\Omega, C_L = 50 \text{ pF}$ EN to D, EN to Ax	1.8 V		58	85	ns
			2.5 V		21	72	
			3.3 V		15	70	
			5 V		11	45	
				$R_L = 10 \text{ k}\Omega, C_L = 15 \text{ pF}$	5		8
t _{BBM}	Break-before-make Time	$R_L = 10 \text{ k}\Omega, C_L = 15 \text{ pF}$ Ax to D, D to Ax	1.8 V	1	16		ns
			2.5 V	1	22		
			3.3 V	1	24		
			5 V	1	33		

(1) Provided by bench test and design simulation.

Typical Performance Characteristics

All test conditions: $T_A = 25^\circ\text{C}$, $V_{CC} = 5\text{ V}$, unless otherwise noted.

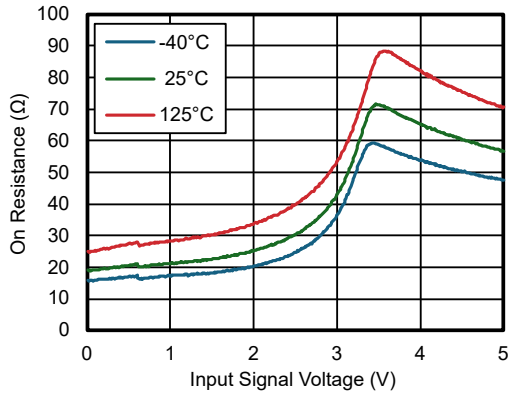

Figure 1. On-Resistance ($V_{CC} = 5\text{ V}$) vs. Temperature

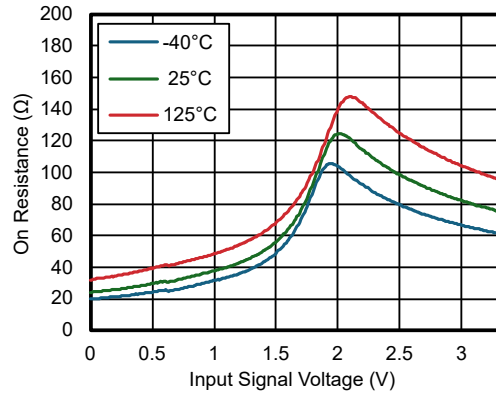

Figure 2. On-Resistance ($V_{CC} = 3.3\text{ V}$) vs. Temperature

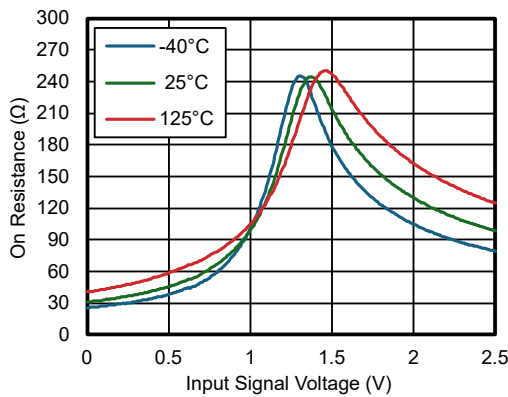

Figure 3. On-Resistance ($V_{CC} = 2.5\text{ V}$) vs. Temperature

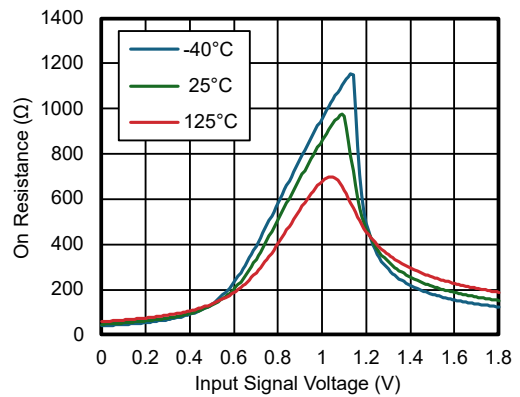

Figure 4. On-Resistance ($V_{CC} = 1.8\text{ V}$) vs. Temperature

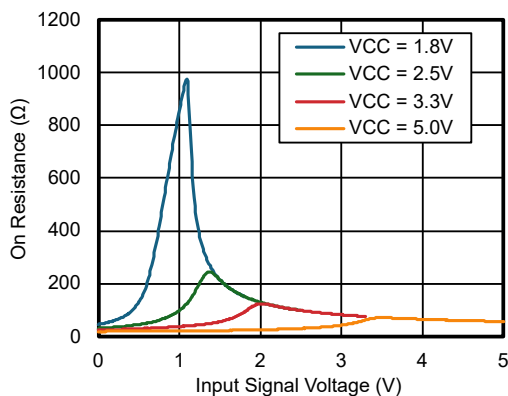

Figure 5. On-Resistance vs. Input Signal Voltage ($T_A = 25^\circ\text{C}$)

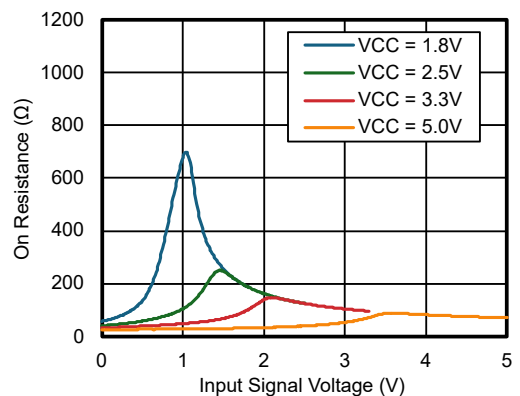

Figure 6. On-Resistance vs. Input Signal Voltage ($T_A = 125^\circ\text{C}$)

5-V General Purpose Analog Switch

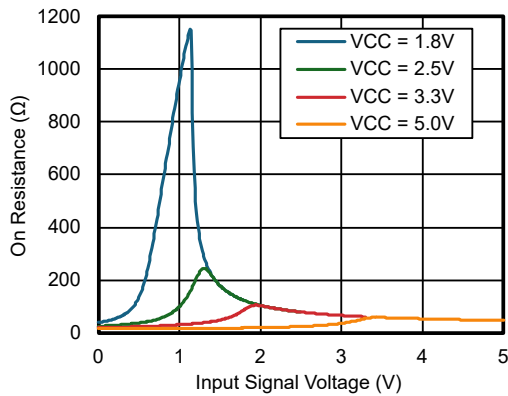

Figure 7. On-Resistance vs. Input Signal Voltage ($T_A = -40^{\circ}\text{C}$)

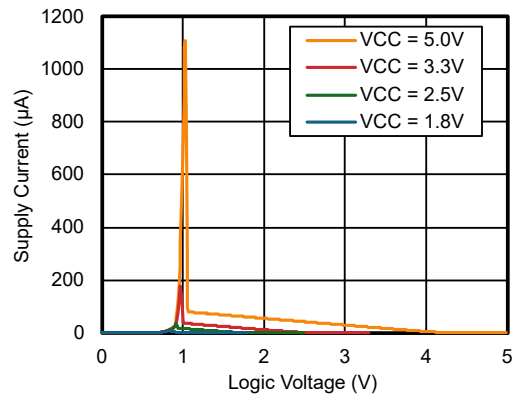

Figure 8. Supply Current vs. Logic Voltage

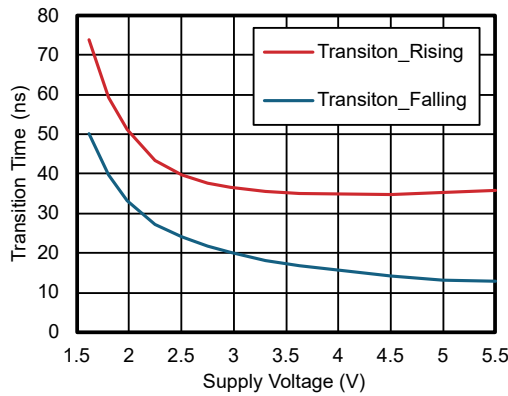

Figure 9. $T_{\text{TRANSITION}}$ vs. Supply Voltage

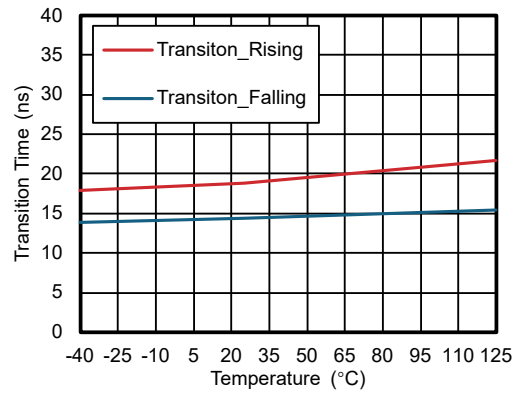

Figure 10. $T_{\text{TRANSITION}}$ vs. Temperature

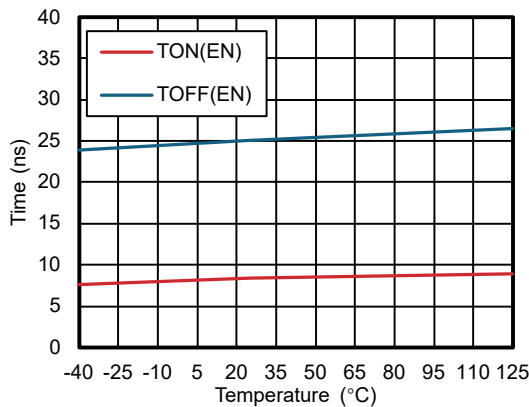

Figure 11. $T_{\text{ON(EN)}}$ and $T_{\text{OFF(EN)}}$ vs. Temperature

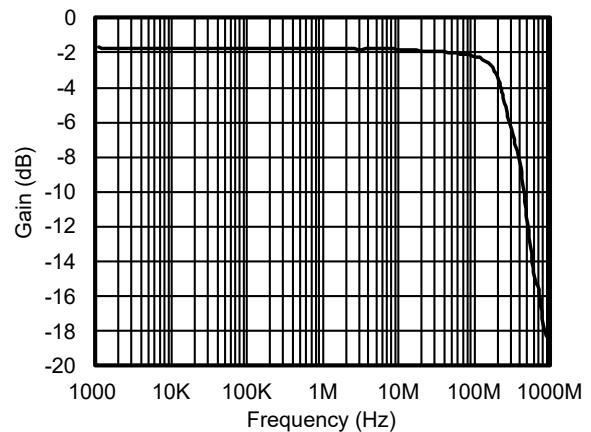

Figure 12. On Response vs. Frequency

5-V General Purpose Analog Switch

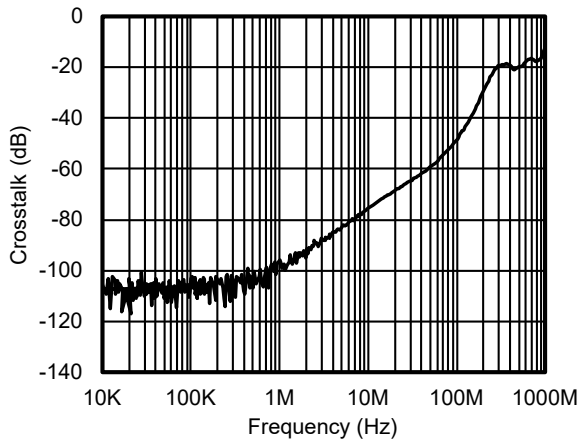

Figure 13. Xtalk vs. Frequency

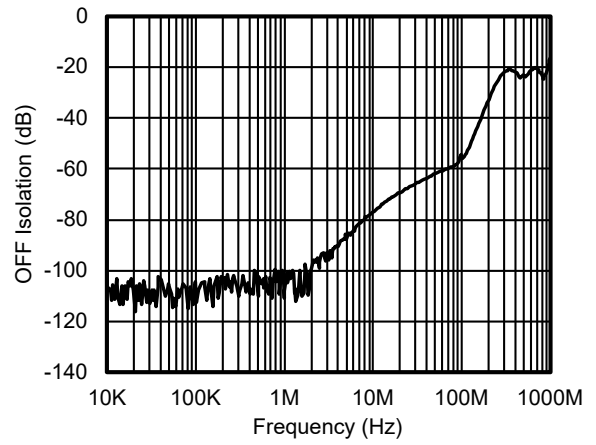

Figure 14. Off-Isolation vs. Frequency

Test Circuits and Waveforms

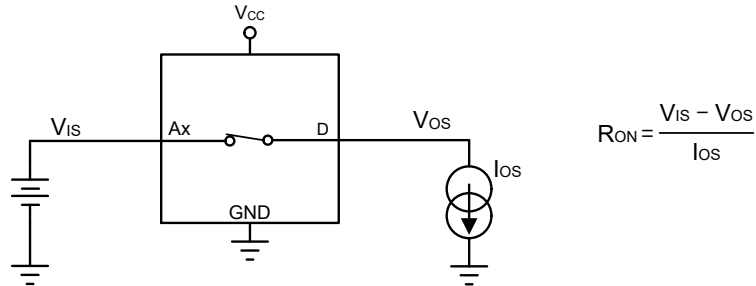

Figure 15. On-Resistance Measurement Setup

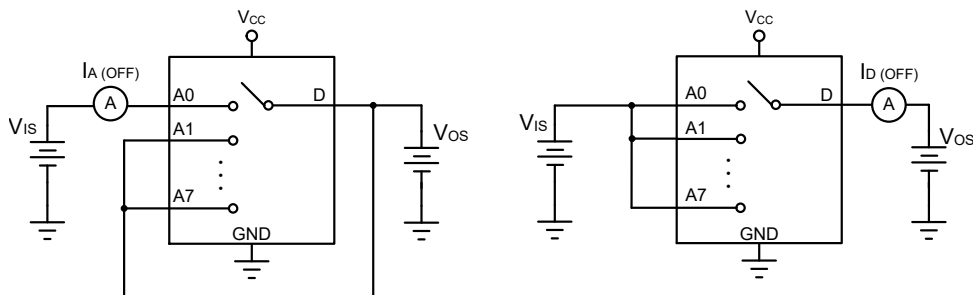

Figure 16. Off-Leakage Measurement Setup

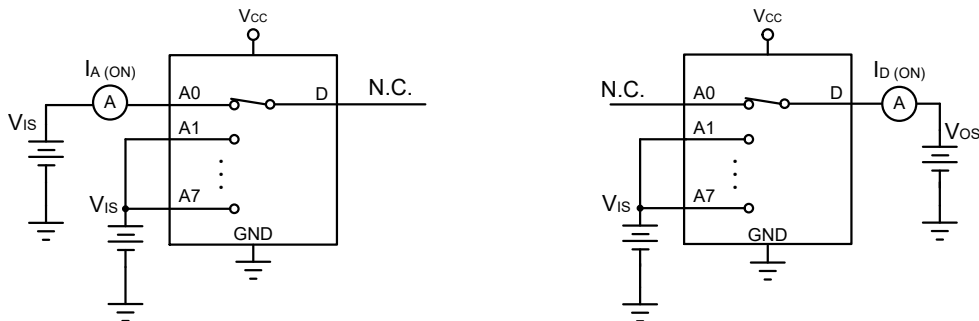

Figure 17. On-Leakage Measurement Setup

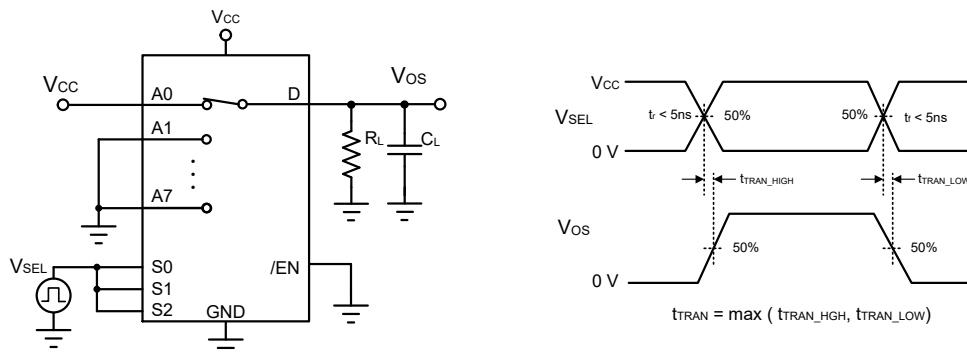

Figure 18. Transition-Time Measurement Setup

5-V General Purpose Analog Switch

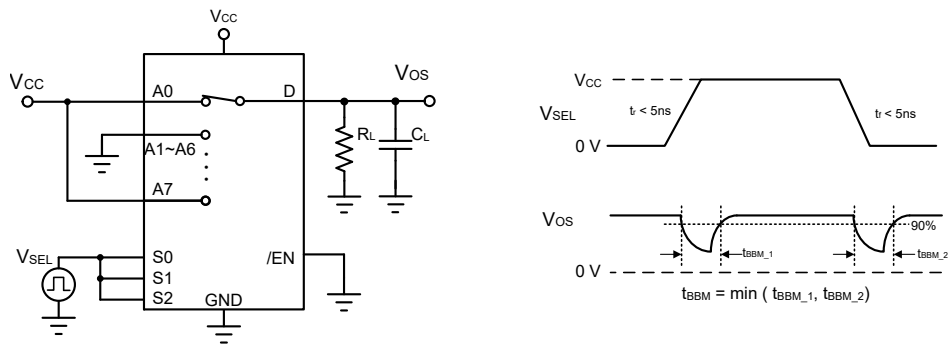

Figure 19. Break-Before-Make Delay Measurement Setup

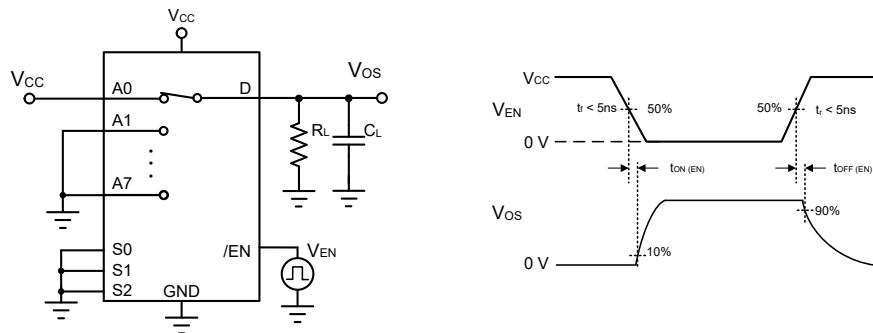

Figure 20. Turn-On and Turn-Off Time Measurement Setup

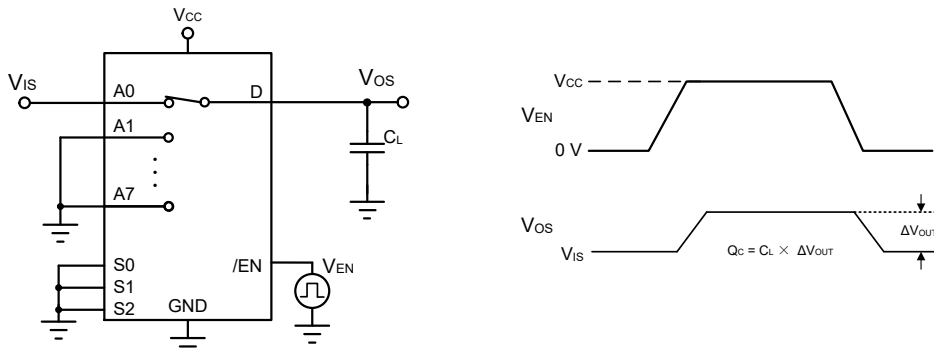

Figure 21. Charge-Injection Measurement Setup

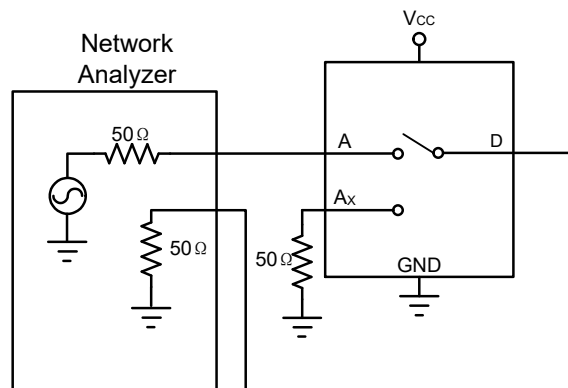

Figure 22. Off Isolation Measurement Setup

5-V General Purpose Analog Switch

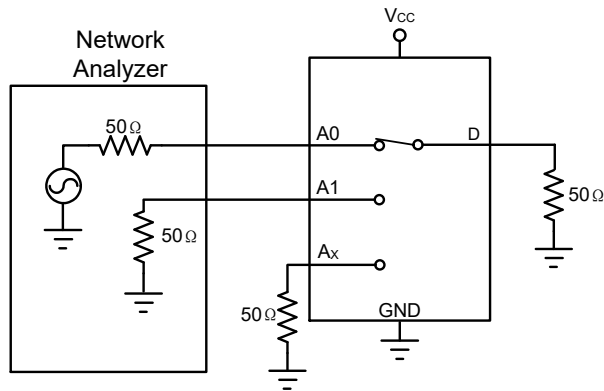

Figure 23. Channel-to-Channel Crosstalk Measurement Setup

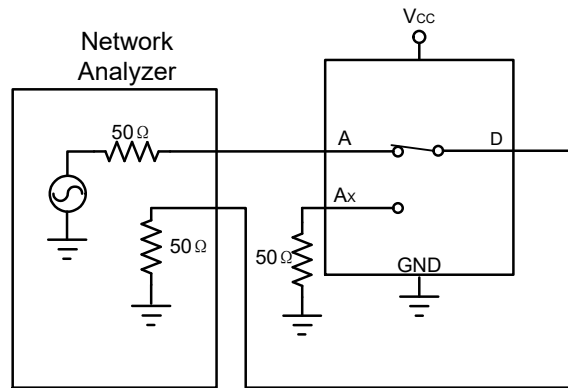

Figure 24. Bandwidth Measurement Setup

Detailed Description

Overview

The TPW3188 is a single-pole octal-throw analog switch (SP8T) suitable for analog or digital 8:1 multiplexer/demultiplexer applications. The switch features three digital select inputs (S0, S1, and S2), eight independent inputs/outputs (An), a common input/output (A), and a digital enable input ($\overline{\text{EN}}$). When EN is HIGH, the switches are turned off.

Functional Block Diagram

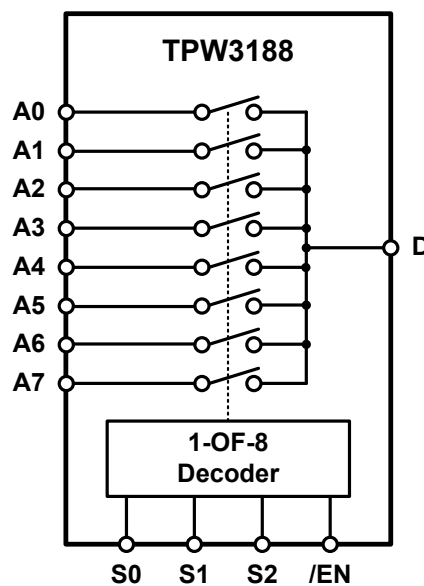

Figure 25. Functional Block Diagram

Feature Description

The TPW3188 is the automotive analog switch qualified as AEC Q100 - automotive grade 1. The VCC voltage range is 1.8 V, 2.5 V, 3.3 V, and 5 V. The Ron resistance is very low, such as typical 75 Ω at Vs = 5 V, typical 120 Ω at Vs = 3.3 V, typical 650 Ω at Vs = 1.8 V. The TPW3188 bandwidth is 250 MHz, it is in break state before the switch operation. The switching time is very fast, which is 22 ns in the ON state, and 8 ns in the OFF time. The TPW3188 is available in the TSSOP16 package and is characterized from -40°C to +125°C.

Application and Implementation

Note

Information in the following application sections is not part of the 3PEAK's component specification and 3PEAK does not warrant its accuracy or completeness. 3PEAK's customers are responsible for determining suitability of components for their purposes. Customers should validate and test their design implementation to confirm system functionality.

Application Information

The TPW3188 line of multiplexers and demultiplexers can be used for a wide variety of applications.

A 0.1- μ F bypass capacitor on V_{CC} is recommended to prevent power disturbance.

The Current per Input into Source or Drain Pin when Input Signal Voltage Exceeds V_{CC}

As the input signal voltage is higher than the V_{CC} voltage, the current per input into source or drain can be very large and close to 50 mA, which may damage the device. Therefore, the input signal is not recommended to exceed V_{CC} .

Input Signal Voltage should be Less Than $V_{CC} + 0.5$ V

The TPW3188 has an internal ESD diode to the GND pin, which is around 20 mA as the diode is turned on. The input signal voltage should NOT be lower than GND-0.5V. A series of resistor is suggested to be added to limit the current. The device requires the input signal voltage be less than $V_{CC} + 0.5$ V. Otherwise, the current increases in exponential magnitude as the input signal voltage rises higher than $V_{CC} + 0.5$ V. Thus, the function cannot be guaranteed in the application and the device may be damaged.

In some special cases, if the input signal voltage exceeds V_{CC} as the channel is in OFF status, the voltage is clamped to $V_{CC}+0.7$ V approximately. The input current may be as large as tens of mA and introduces coupling to other channels, so the device is not recommended in this case.

Typical Application

One application of the TPT3188 device is used in conjunction with a microcontroller to poll a keypad. [Figure 26](#) shows the basic schematic for such a polling system.

The microcontroller uses channel-select pins to cycle through different channels while reading the input to see if a user is pressing any of the keys. This is a very robust setup that allows for simultaneous key presses with very little power consumption. It also uses very few pins on the microcontroller. The down side of polling is that the microcontroller must frequently scan the keys for a press.

5-V General Purpose Analog Switch

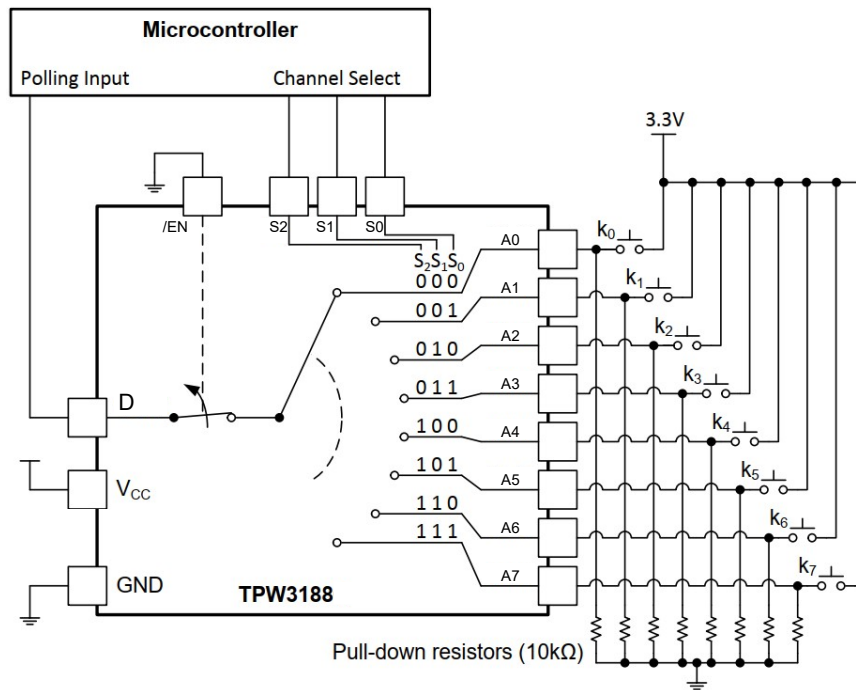

Figure 26. Typical Application Circuit

Layout

Layout Example

Reflections and matching are closely related to loop antenna theory, but different enough to warrant their own discussion. When a PCB trace turns a corner at a 90° angle, a reflection can occur. This is primarily due to the change in width of the trace. At the apex of the turn, the trace width is increased to 1.414 times its width. This change in the width upsets the transmission line characteristics, especially the distributed capacitance and self-inductance of the trace, thus resulting in the reflection. Not all PCB traces can be straight, so they have to turn corners. Figure 27 shows progressively better techniques of rounding corners. Only the last example (BEST) maintains constant trace width and minimizes reflections.

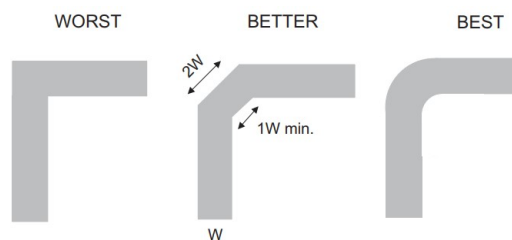

Figure 27. Trace Example

Route high-speed signals using a minimum of vias and corners which reduces signal reflections and impedance changes. When a via must be used, increase the clearance size around it to minimize its capacitance. Each via introduces discontinuities in the signal's transmission line and increases the chance of picking up interference from the other layers of the board. Be careful when designing test points, through-hole pins are not recommended at high frequencies.

Figure 28 illustrates an example of a PCB layout with the TPW3188. Some key considerations are:

- Decouple the VDD pin with a 0.1- μ F capacitor, and place as close to the pin as possible. Make sure that the capacitor voltage rating is sufficient for the VDD supply.
- Decouple the VDD pin with a 0.1- μ F capacitor, and place as close to the pin as possible. Make sure that the capacitor voltage rating is sufficient for the VDD supply.
- Keep the input lines as short as possible.
- Use a solid ground plane to help reduce electromagnetic interference (EMI) noise pickup.
- Do not run sensitive analog traces in parallel with digital traces. Avoid crossing digital and analog traces if possible, and only make perpendicular crossings when necessary.

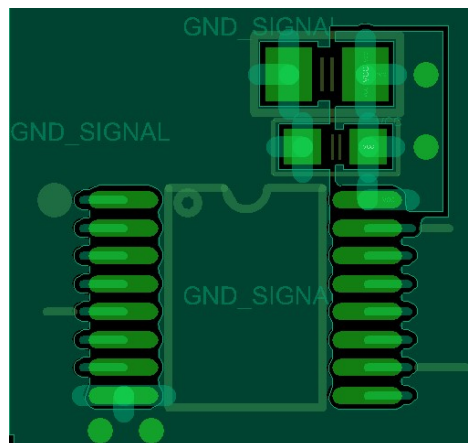
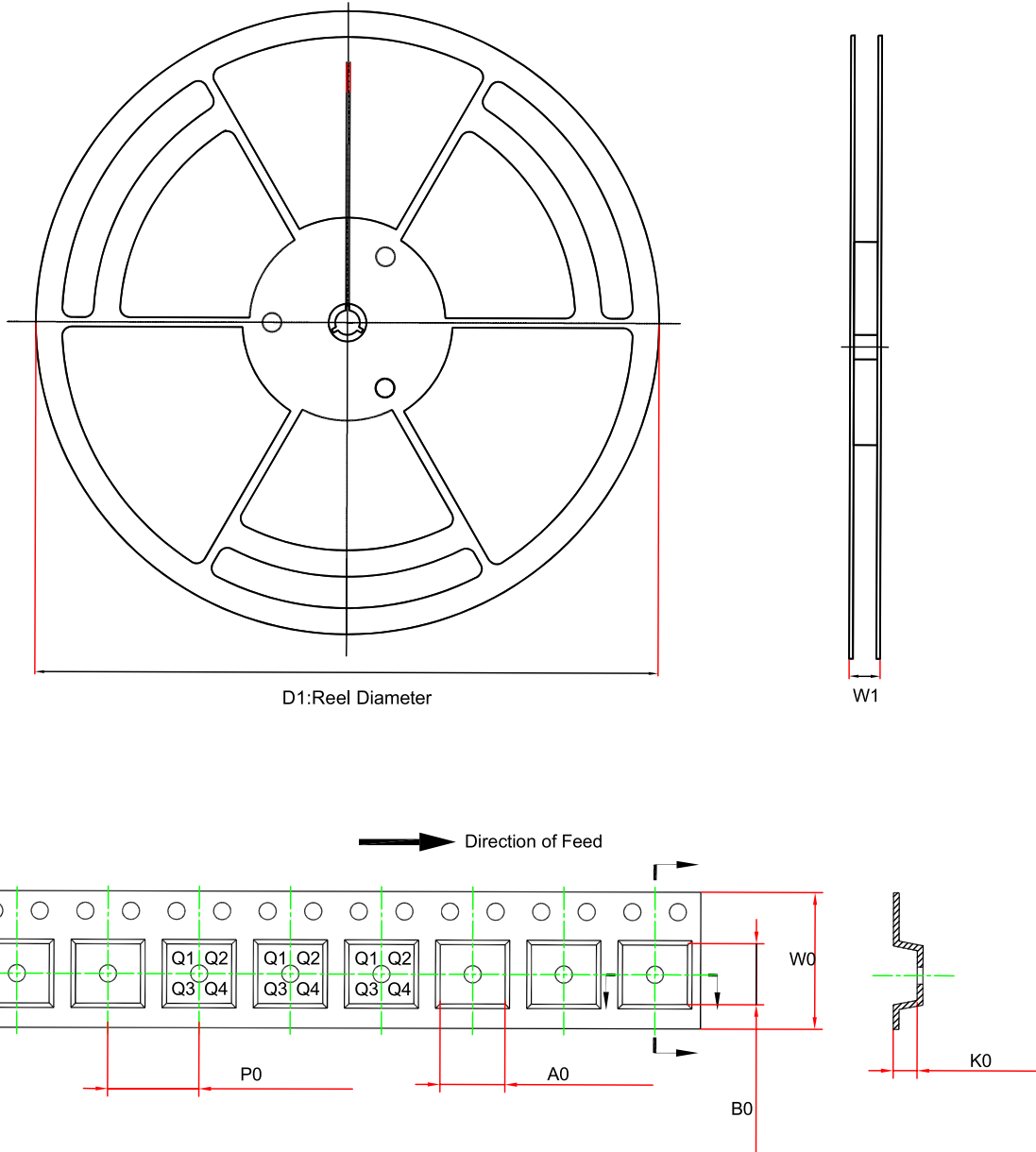

Figure 28. TPW3188 Layout Example

Tape and Reel Information



Order Number	Package	D1 (mm)	W1 (mm)	A0 (mm) ⁽¹⁾	B0 (mm) ⁽¹⁾	K0 (mm) ⁽¹⁾	P0 (mm)	W0 (mm)	Pin1 Quadrant
TPW3188-TS3R-S	TSSOP16	330	17.6	6.8	5.5	1.5	8	12	Q1
TPW3188-TS3R	TSSOP16	330	17.6	6.8	5.5	1.5	8	12	Q1

(1) The value is for reference only. Contact the 3PEAK factory for more information.

Package Outline Dimensions

TSSOP16

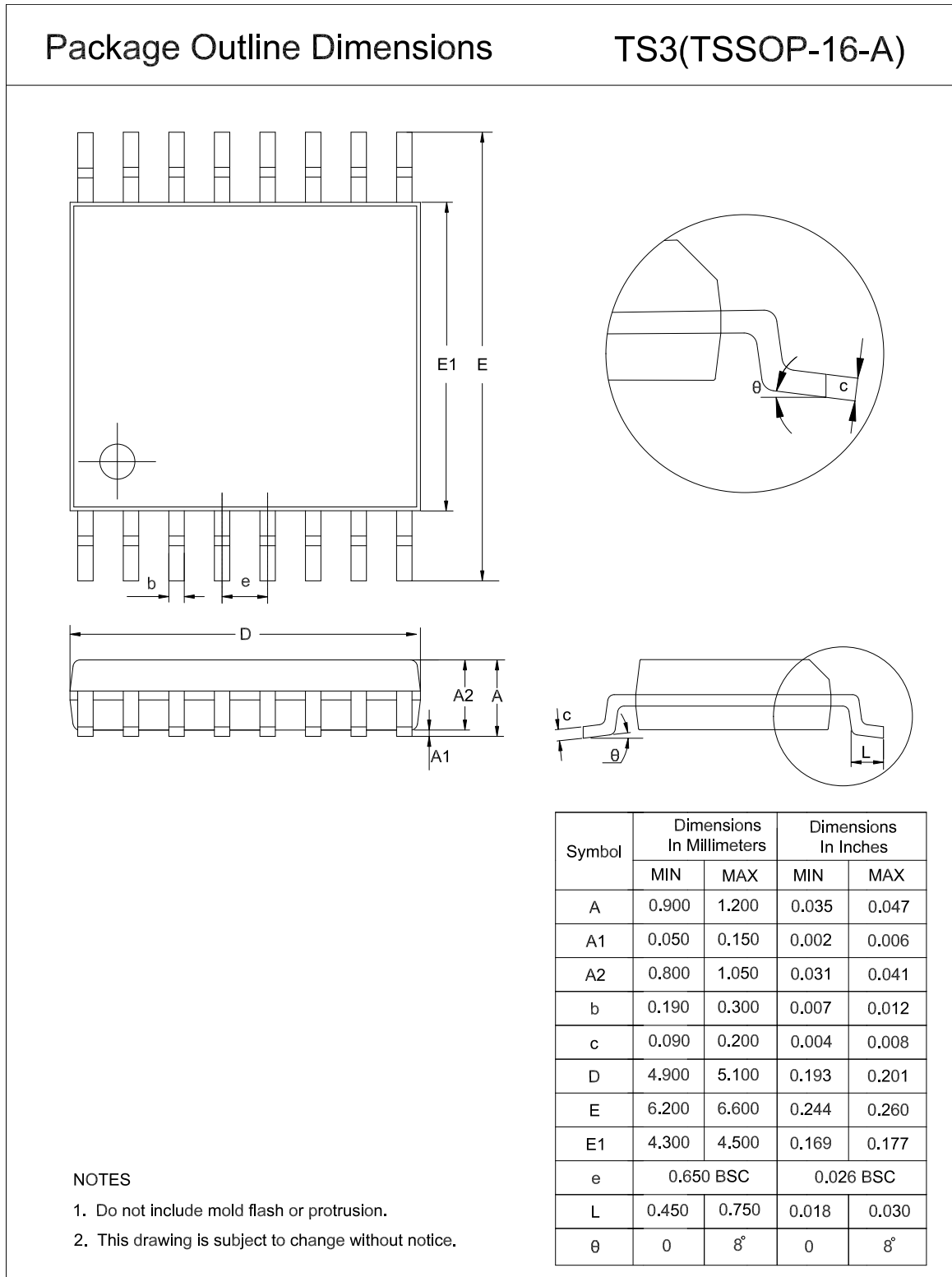

QFN2.5X3.5-16

Package Outline Dimensions QN4(QFN2.5X3.5-16-WET-B)

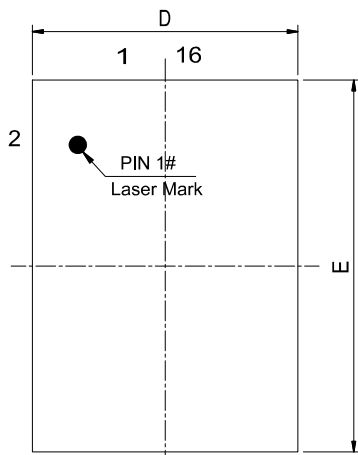

TOP VIEW

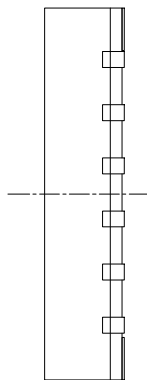

SIDE VIEW

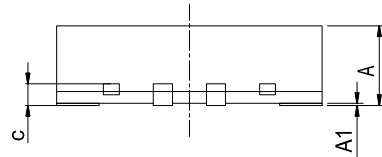

SIDE VIEW

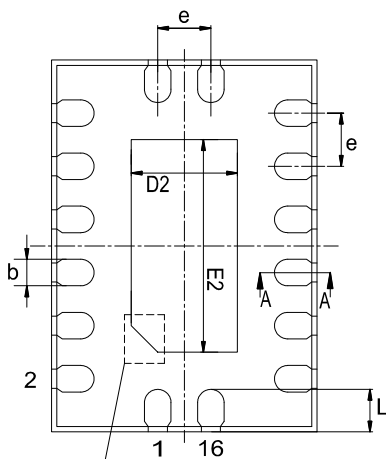

BOTTOM VIEW

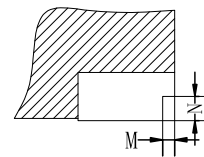

Section A-A



NOTES

1. Do not include mold flash or protrusion.
2. This drawing is subject to change without notice.
3. The many types of E-pad Pin1 signs may appear in the product.

Symbol	Dimensions In Millimeters		Dimensions In Inches	
	MIN	MAX	MIN	MAX
A	0.700	0.800	0.028	0.031
A1	0.000	0.050	0.000	0.002
b	0.200	0.300	0.008	0.012
c	0.203 TYP		0.008 TYP	
D	2.400	2.600	0.094	0.102
E	3.400	3.600	0.134	0.142
e	0.500 BSC		0.020 BSC	
D2	0.900	1.100	0.035	0.043
E2	1.900	2.100	0.075	0.083
L	0.300	0.500	0.012	0.020
M	0.010	0.090	0.000	0.004
N	0.080	0.180	0.003	0.007

SOP16

Package Outline Dimensions

SO3(SOP-16-A)

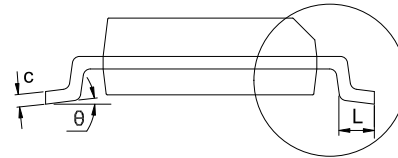
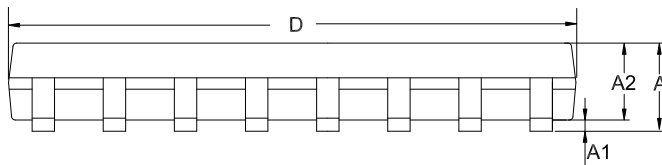
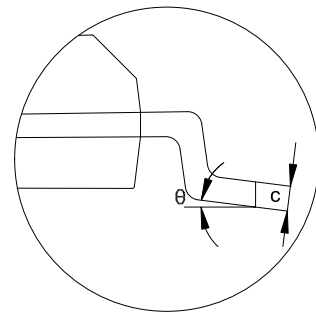
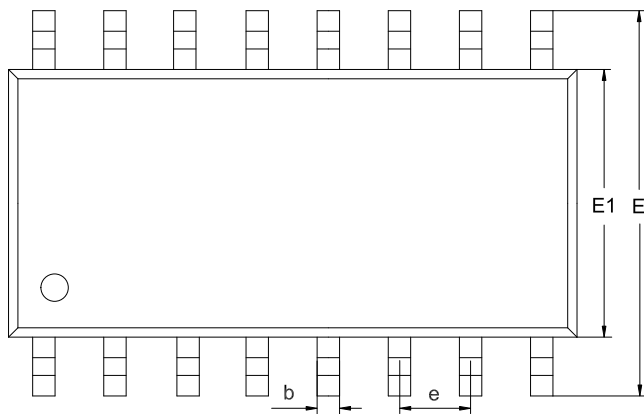

Symbol	Dimensions In Millimeters		Dimensions In Inches	
	MIN	MAX	MIN	MAX
A	1.350	1.750	0.053	0.069
A1	0.050	0.250	0.002	0.010
A2	1.300	1.600	0.051	0.063
b	0.330	0.510	0.013	0.020
c	0.170	0.250	0.007	0.010
D	9.800	10.000	0.386	0.394
E	5.800	6.200	0.228	0.244
E1	3.800	4.000	0.150	0.157
e	1.270 BSC		0.050 BSC	
L	0.400	1.000	0.016	0.039
θ	0	8°	0	8°

NOTES

1. Do not include mold flash or protrusion.
2. This drawing is subject to change without notice.

Order Information

Order Number	Operating Temperature Range	Package	Marking Information	MSL	Transport Media, Quantity	Eco Plan
TPW3188-TS3R-S ⁽¹⁾	-40 to 125°C	TSSOP16	3188O	MSL3	Tape and Reel, 3000	Green
TPW3188-TS3R	-40 to 125°C	TSSOP16	3188O	MSL3	Tape and Reel, 3000	Green
TPW3188-QN4R ⁽²⁾	-40 to 125°C	QFN2.5X3.5-16	3188O	MSL3	Tape and Reel, 4000	Green
TPW3188-SO3R ⁽²⁾	-40 to 125°C	SOP16	3188O	MSL3	Tape and Reel, 2500	Green

(1) Qualified for Automotive Applications with AEC-Q100 Reliability Test.

(2) For future products, contact the 3PEAK factory for more information and samples.

Green: 3PEAK defines "Green" to mean RoHS compatible and free of halogen substances.

IMPORTANT NOTICE AND DISCLAIMER

Copyright© 3PEAK 2012-2025. All rights reserved.

Trademarks. Any of the 思瑞浦 or 3PEAK trade names, trademarks, graphic marks, and domain names contained in this document /material are the property of 3PEAK. You may NOT reproduce, modify, publish, transmit or distribute any Trademark without the prior written consent of 3PEAK.

Performance Information. Performance tests or performance range contained in this document/material are either results of design simulation or actual tests conducted under designated testing environment. Any variation in testing environment or simulation environment, including but not limited to testing method, testing process or testing temperature, may affect actual performance of the product.

Disclaimer. 3PEAK provides technical and reliability data (including data sheets), design resources (including reference designs), application or other design recommendations, networking tools, security information and other resources "As Is". 3PEAK makes no warranty as to the absence of defects, and makes no warranties of any kind, express or implied, including without limitation, implied warranties as to merchantability, fitness for a particular purpose or non-infringement of any third-party's intellectual property rights. Unless otherwise specified in writing, products supplied by 3PEAK are not designed to be used in any life-threatening scenarios, including critical medical applications, automotive safety-critical systems, aviation, aerospace, or any situations where failure could result in bodily harm, loss of life, or significant property damage. 3PEAK disclaims all liability for any such unauthorized use.