

Features

- Exceeds Requirements of EIA-485 Standard
- Hot Plug Circuitry - Tx and Rx Outputs Remain Three-State During Power-up/Power-down
- Supply Voltage: 3.0 V ~ 5.5 V
- Data Rate: 500-kbps Isolated RS485
- Full Fail-safe Receiver (Open, Short, Terminated)
- Up to 5-kV RMS Isolation Rating
- $\pm 200\text{-kV}/\mu\text{s}$ typ Static CMTI, $\pm 150\text{-kV}/\mu\text{s}$ typ Dynamic CMTI
- Latch-up Performance Exceeds 600 mA
- Bus-Pin Protection (Between Bus pins and GNDB)
 - $\pm 15\text{-kV}$ IEC 61000-4-2 Contact Discharge
 - $\pm 20\text{-kV}$ IEC 61000-4-2 Air Discharge
- Safety-Related Certifications:
 - VDE Certification according to DIN VDE V 0884-17(IEC60747-17)
 - 5000-VRMS Isolation Rating per UL 1577
 - CQC Certification per GB 4943.1
 - CSA, TUV, and CB Certifications

Applications

- Home Appliance
- Motor Drives
- Industrial Control
- Communication Infrastructure

Description

The TPT7487 is a $\pm 15\text{-kV}$ IEC61000 ESD protected, 3.0-V ~ 5.5-V isolated RS485 transceivers that meet the RS-485 and RS-422 standards for Half Duplex communication. The TPT7488 is isolated Full Duplex RS485.

The TPT748x features a fail-safe receiver, which supports the output of the receiver to be logic high when the differential input (bus pin A/B) of the receiver is open, short, or idle.

Transmitters in this family deliver exceptional differential output voltages into the RS-485 required 54- Ω load. The 500-kbps device has very low bus currents, so they present a true “1/8 unit load” to the RS-485 bus. This allows up to 256 transceivers on the network without using repeaters. Receiver (Rx) inputs feature a “Full Fail-Safe” design, which ensures a logic-high Rx output if Rx inputs are floating, shorted, or on a terminated but undriven bus.

The TPT748x is available in the WSOP16 package and is characterized from -40°C to $+125^{\circ}\text{C}$.

Functional Block Diagram

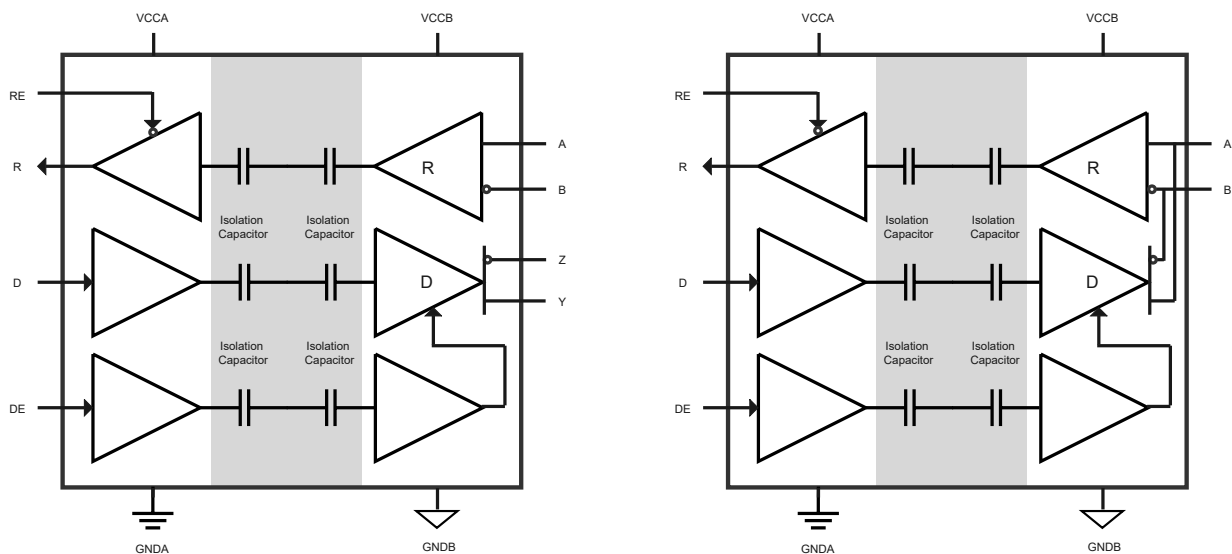

Table of Contents

Features	1
Applications	1
Description	1
Functional Block Diagram	1
Revision History	3
Pin Configuration and Functions	4
Specifications	6
Absolute Maximum Ratings ⁽¹⁾	6
ESD, Electrostatic Discharge Protection.....	6
Recommended Operating Conditions.....	6
Thermal Information.....	7
Insulation Specifications.....	7
Safety-Related Certifications.....	9
Electrical Characteristics.....	10
Electrical Characteristics (continued)	11
Switching Characteristics.....	12
Test Circuits and Waveforms.....	13
Detailed Description	15
Overview.....	15
Functional Block Diagram.....	15
Feature Description.....	16
Tape and Reel Information	17
Package Outline Dimensions	18
WSOP16.....	18
Order Information	19
IMPORTANT NOTICE AND DISCLAIMER	20

Revision History

Date	Revision	Notes
2022-03-10	Rev.Pre.0	Initial Version
2022-09-08	Rev.A.0	Released Version
2023-11-15	Rev.A.1	Updated new format and EC table

Pin Configuration and Functions

TPT7487
WSOP16
Top View

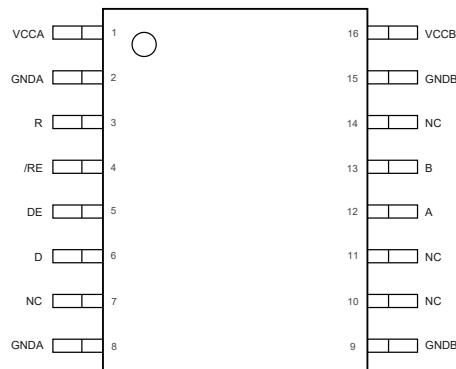

Table 1. Pin Functions: TPT7487

Pin No.	Name	I/O	Description
1	VCCA	–	Logic-side power supply
2	GNDA	–	Ground connection for VCCA
3	R	O	Receiver output
4	/RE	I	Receiver enable. This pin disables the receiver output when high or open and enables the receiver output when low.
5	DE	I	Driver enable. This pin enables the driver output when high and disables the driver output when low or open.
6	D	I	Driver input
7	NC	–	Not Connected
8	GNDA	–	Ground connection for VCCA
9	GNDB	–	Ground connection for VCCB
10	NC	–	Not Connected
11	NC	–	Not Connected
12	A	I/O	Transceiver non-inverting input or output (I/O) on the bus side
13	B	I/O	Transceiver inverting input or output (I/O) on the bus side
14	NC	–	Not Connected
15	GNDB	–	Ground connection for VCCB
16	VCCB	–	Transceiver-side power supply

Isolated Full- and Half-Duplex RS485 Transceiver

TPT7488
WSOP16
Top View

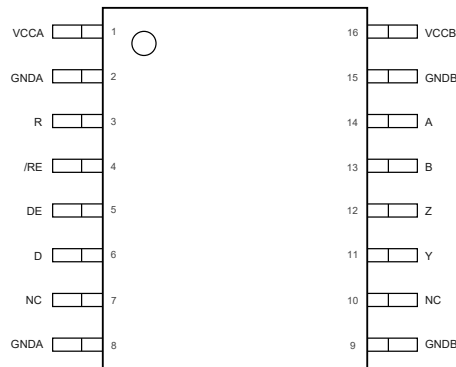

Table 2. Pin Functions: TPT7488

Pin No.	Name	I/O	Description
1	VCCA	—	Logic-side power supply
2	GNDA	—	Ground connection for VCCA
3	R	O	Receiver output
4	/RE	I	Receiver enable. This pin disables the receiver output when high or open and enables the receiver output when low.
5	DE	I	Driver enable. This pin enables the driver output when high and disables the driver output when low or open.
6	D	I	Driver input
7	NC	—	Not Connected
8	GNDA	—	Ground connection for VCCA
9	GNDB	—	Ground connection for VCCB
10	NC	—	Not Connected
11	Y	O	Driver non-inverting output
12	Z	O	Driver inverting output
13	B	I	Receiver inverting input on the bus side
14	A	I	Receiver non-inverting input on the bus side
15	GNDB	—	Ground connection for VCCB
16	VCCB	—	Transceiver-side power supply

Specifications

Absolute Maximum Ratings ⁽¹⁾

Parameter		Min	Max	Unit
V _{CC}	Supply Voltage, V _{CCA} , V _{CCB}	-0.5	6	V
V _{IO}	Voltage at Logic Pin: D, DE, /RE, R	-0.5	6	V
V _{BUS}	Voltage at Bus Pin: A, B	-15	15	V
T _A	Operating Temperature Range	-40	125	°C
T _J	Maximum Junction Temperature	-40	150	°C
T _S	Storage Temperature Range	-65	150	°C
T _{Lead}	Lead Temperature (Soldering, 10 sec)	-	260	°C

(1) Stresses beyond those listed under Absolute Maximum Ratings may cause permanent damage to the device. Exposure to any Absolute Maximum Rating condition for extended periods may affect device reliability and lifetime.

(2) This data was taken with the JEDEC low effective thermal conductivity test board.

(3) This data was taken with the JEDEC standard multilayer test boards.

ESD, Electrostatic Discharge Protection

Parameter		Condition	Value	Unit
IEC	IEC-61000-4-2, Contact Discharge	Bus pin to GNDB	±15	kV
	IEC-61000-4-2, Air-Gap Discharge	Bus pin to GNDB	±20	kV
HBM	HBM, per ANSI/ESDA/JEDEC JS-001 ⁽¹⁾	Bus pin to GNDB	±18	kV
		All Pins except bus pin	±7	kV
CDM	CDM, per ANSI/ESDA/JEDEC JS-002 ⁽²⁾	All pins	±1.5	kV
LU	Latch up, per JESD78	All pins	±600	mA

(1) JEDEC document JEP155 states that 500-V HBM allows safe manufacturing with a standard ESD control process.

(2) JEDEC document JEP157 states that 250-V CDM allows safe manufacturing with a standard ESD control process.

Recommended Operating Conditions

Parameter		Min	Max	Unit
V _{CC}	Supply Voltage	3.0	5.5	V
V _I	Input Voltage at any Bus Terminal	-7	12	V
V _{IH}	High-level Input Voltage (driver, driver enable, and receiver enable inputs)	2	V _{CC}	V
V _{IL}	Low-level Input Voltage (driver, driver enable, and receiver enable inputs)	0	0.8	V
V _{ID}	Differential Input Voltage	-7	12	V

Isolated Full- and Half-Duplex RS485 Transceiver

Parameter		Min	Max	Unit
R _L	Differential Load Resistance	54	-	Ω

Thermal Information

Package Type	θ _{JA}	θ _{JC}	Unit
WSOP16	75	41	°C/W

Insulation Specifications

Parameter		Conditions	Value	Unit
			WSOP16	
CLR	External clearance	Shortest terminal-to-terminal distance through air	> 8.0	mm
CPG	External creepage	Shortest terminal-to-terminal distance across the package surface	> 8.0	mm
DTI	Distance through the insulation	Minimum internal gap (internal clearance)	> 22	μm
DTC	Distance through the Molding compound	Minimum internal distance across the conductors inside the package	0.8	mm
CTI	Comparative tracking index		> 600	V
	Material group		I	-
	Over-voltage category	For Rated Mains Voltage ≤ 150 V _{RMS}	I-IV	-
		For Rated Mains Voltage ≤ 300 V _{RMS}	I-IV	-
		For Rated Mains Voltage ≤ 600 V _{RMS}	I-IV	-
		For Rated Mains Voltage ≤ 1000 V _{RMS}	I-III	-
	Climatic category		40/125/21	-
	Pollution degree		2	-

DIN V VDE V 0884-17 ⁽¹⁾⁽²⁾

V _{IORM}	Maximum repetitive isolation voltage	AC voltage	1414	V _{PK}
V _{IOWM}	Maximum working isolation voltage	AC voltage; TDDB Test	1000	V _{RMS}
		DC voltage	1414	V _{DC}
V _{IOTM}	Maximum transient isolation voltage	V _{TEST} = V _{IOTM} , t = 60 s (qualification); V _{TEST} = 1.2 × V _{IOTM} , t = 1 s (100% production)	7070	V _{PK}
V _{IOSM}	Maximum surge isolation voltage ⁽³⁾	Test method per IEC 62368-1, 1.2/50 μs waveform, V _{TEST} = 1.3 × V _{IOSM} (qualification)	6500	V _{PK}
q _{pd}	Apparent charge	Method a, After Input/Output safety test subgroup 2/3, V _{ini} = V _{IOTM} , t _{ini} = 60 s; V _{pd(m)} = 1.2 × V _{IORM} , t _m = 10 s	≤ 5	pC

Isolated Full- and Half-Duplex RS485 Transceiver

Parameter		Conditions	Value	Unit
			WSOP16	
		Method a, After environmental tests subgroup 1, $V_{ini} = V_{IOTM}$, $t_{ini} = 60$ s; $V_{pd(m)} = 1.6 \times V_{IORM}$, $t_m = 10$ s	≤ 5	
		Method b1; At routine test (100% production) and preconditioning (type test), $V_{ini} = 1.2 \times V_{IOTM}$, $t_{ini} = 1$ s; $V_{pd(m)} = 1.875 \times V_{IORM}$, $t_m = 1$ s	≤ 5	
C_{IO}	Isolation capacitance	$V_{IO} = 0.4 \times \sin(2\pi ft)$, $f = 1$ MHz	~ 0.5	pF
R_{IO}	Isolation resistance	$V_{IO} = 500$ V, $T_A = 25^\circ\text{C}$	$> 10^{12}$	Ω
		$V_{IO} = 500$ V, $100^\circ\text{C} \leq T_A \leq 125^\circ\text{C}$	$> 10^{11}$	Ω
		$V_{IO} = 500$ V at $T_S = 150^\circ\text{C}$	$> 10^9$	Ω
UL 1577				
V_{ISO}	Withstanding isolation voltage	$V_{TEST} = V_{ISO}$, $t = 60$ s (qualification); $V_{TEST} = 1.2 \times V_{ISO}$, $t = 1$ s (100% production)	5000	V_{RMS}

- (1) All pins on each side of the barrier are tied together creating a two-terminal device.
- (2) This coupler is suitable for safe electrical insulation only within the safety operating ratings. Compliance with the safety ratings shall be ensured by means of suitable protective circuits.
- (3) Testing must be carried out in oil.

Isolated Full- and Half-Duplex RS485 Transceiver
Safety-Related Certifications

VDE	UL	TUV	CQC	CSA	CB
Certified according to DIN VDE V 0884-17	Certified according to UL 1577 and CSA Component Acceptance Notice 5A	Certified according to EN IEC 62368-1 and EN IEC 61010-1	Certified according to GB 4943.1	Certified CSA C22.2 No. 62368-1 and CAN/CSA-C22.2 No. 60601-1	Certified according to EN IEC 62368-1
Basic insulation (WSOP) VIORM= 1414 VIOSM= 6500 (SOP, QSOP) VIORM= 637 VIOSM= 5980	(WSOP)Single protection, 5000Vrms (SOP, QSOP)Single protection, 3750Vrms	6400Vrms reinforced insulation (WSOP), 800Vrms maximum work voltage 4000Vrms basic insulation (SOP, QSOP), 400V rms maximum work voltage	Reinforced insulation (WSOP), Altitude<=5000m, 800V rms maximum work voltage. Basic insulation (SOP, QSOP), Altitude<=5000m, 400V rms maximum work voltage.	400Vrms basic insulation (SOP, QSOP) and 600V rms reinforced insulation (WSOP) working voltage per CSA C22.2 No. 62368-1:19 3rd, IEC 62368-1:2018 Ed. 3(in pollution degree 2, material group I) 2 MOPP (Means of Patient Protection) insulation requirements for 250Vrms (WSOP) in CAN/CSA-C22.2 No. 60601-1:14, IEC 60601-1:2005 + AMD1:2012	Reinforced insulation (WSOP), Altitude<=5000m, 800V rms maximum work voltage. Basic insulation (SOP, QSOP), Altitude<=5000m, 400V rms maximum work voltage.
Certificate No. 40054570	Report Reference E524241	Customer Number : 2332359	Certificate No. CQC22001356658	Master contract: 302375	Ref. Certif. No. CN57658

Electrical Characteristics

All test conditions: $V_{CCA} = 2.25\text{ V to }5.5\text{ V}$, $V_{CCB} = 3\text{ V to }5.5\text{ V}$, $T_A = -40^\circ\text{C to }125^\circ\text{C}$, unless otherwise noted.

Parameter		Test Conditions	Min	Typ	Max	Unit
V _{Od}	Driver Differential Output Voltage Magnitude	R _L = 54 Ω, V _{CCB} = 3.3 V	1.5	2.2	-	V
		R _L = 54 Ω, V _{CCB} = 5.0 V	2.0	3.3	-	V
		R _L = 100 Ω, V _{CCB} = 3.3 V	1.5	2.6	-	V
		R _L = 100 Ω, V _{CCB} = 5.0 V	2.0	3.9	-	V
Δ V _{Od}	Change in Magnitude of Driver Differential Output Voltage		-200	-	200	mV
V _{Oc(ss)}	Steady-state Common-mode Output Voltage	Center of two 27-Ω load resistors	1	V _{CC} /2	3	V
ΔV _{Oc}	Change in Differential Driver Output Common-mode Voltage		-200	-	200	mV
C _{OD}	Differential Output Capacitance ⁽¹⁾		-	15	-	pF
V _{IT+}	Positive-going Receiver Differential Input Voltage Threshold		-	-110	-50	mV
V _{IT-}	Negative-going Receiver Differential Input Voltage Threshold		-200	-130	-	mV
V _{HYS}	Receiver Differential Input Voltage threshold Hysteresis (V _{IT+} – V _{IT-}) ⁽¹⁾		-	50	-	mV
V _{OH}	Receiver High-level Output Voltage	V _{CCA} = 3.3 V, I _{OH} = -2 mA	2.7	3.2	-	V
		V _{CCA} = 5 V, I _{OH} = -4 mA	4.1	4.8	-	
V _{OL}	Receiver Low-level Output Voltage	V _{CCA} = 3.3 V, I _{OL} = 2 mA	-	0.09	0.3	V
		V _{CCA} = 5 V, I _{OL} = 4 mA	-	0.17	0.4	
V _{IH}	Input High Logic Level	D, DE, /RE	2.0	-	-	V
V _{IL}	Input Low Logic Level	D, DE, /RE	-	-	0.8	V
I _{IN}	Driver Input, driver enable, and receiver enable input current ⁽¹⁾	D, DE, /RE	-	3	-	μA
I _{OZ}	Driver Output high-Z current	V _O = -7 V	-100	-	-	μA
		V _O = 12 V		-	125	μA
I _{OZ}	Receiver high-Z current ⁽¹⁾	V _O = 0 V or V _{CCA}	-	0.1	-	μA
I _{OS}	Driver Short-circuit Output Current	V _{DE} = V _{CCA} , V _{CCB} = 3.0 ~ 5.5 V	-250	-	250	mA

(1) Parameters are provided by lab bench test and design simulation.

Isolated Full- and Half-Duplex RS485 Transceiver
Electrical Characteristics (continued)

 All test conditions: $V_{CCA} = 2.25\text{ V to }5.5\text{ V}$, $V_{CCB} = 3\text{ V to }5.5\text{ V}$, $T_A = -40^\circ\text{C to }125^\circ\text{C}$, unless otherwise noted.

Parameter		Test Conditions		Min	Typ	Max	Unit
$I_{IA/B}$	Bus input current (disabled driver)	DE = 0 V, /RE = V_{CCA}	$V_I = 12\text{ V}$,	-	55	125	μA
			$V_I = -7\text{ V}$,	-100	-50	-	μA
I_{CCA}	Supply current, DC	Driver and Receiver enabled	$V_{CCA} = 5\text{ V}$, No load	-	6.9	9.8	mA
			$V_{CCA} = 3.3\text{ V}$, No load	-	6.8	9.8	mA
		Driver enable and Receiver disabled	$V_{CCA} = 5\text{ V}$, No load	-	6.9	9.8	mA
			$V_{CCA} = 3.3\text{ V}$, No load	-	6.8	9.8	mA
		Driver disable and Receiver enabled	$V_{CCA} = 5\text{ V}$, No load	-	3.4	5	mA
			$V_{CCA} = 3.3\text{ V}$, No load	-	3.4	5	mA
		Driver and receiver disabled	$V_{CCA} = 5\text{ V}$, No load	-	3.4	5	mA
			$V_{CCA} = 3.3\text{ V}$, No load	-	3.4	5	mA
I_{CCA}	Supply current, 500kbps	Driver and Receiver enabled	$V_{CCA} = 5\text{ V}$, No load	-	9	14	mA
			$V_{CCA} = 3.3\text{ V}$, No load	-	8.9	14	mA
		Driver enable and Receiver disabled	$V_{CCA} = 5\text{ V}$, No load	-	8.9	14	mA
			$V_{CCA} = 3.3\text{ V}$, No load	-	8.9	14	mA
		Driver disable and Receiver enabled	$V_{CCA} = 5\text{ V}$, No load	-	3.4	6.8	mA
			$V_{CCA} = 3.3\text{ V}$, No load	-	3.3	6.8	mA
I_{CCB}	Supply current, DC	Driver enabled	$V_{CCB} = 5\text{ V}$, No load	-	3.9	6.5	mA
			$V_{CCB} = 3.3\text{ V}$, No load	-	3.8	6.3	mA
		Driver and Receiver enabled	$V_{CCB} = 5\text{ V}$, RL=54 Ω	-	73	93	mA
			$V_{CCB} = 3.3\text{ V}$, RL=54 Ω	-	48	61	mA
		Driver disabled	$V_{CCB} = 5\text{ V}$, No load	-	3.9	6.3	mA
			$V_{CCB} = 3.3\text{ V}$, No load	-	3.8	6.2	mA
I_{CCB}	Supply current, 500kbps	Driver and Receiver enabled	$V_{CCB} = 5\text{ V}$, RL=54 Ω	-	108.8	160	mA
			$V_{CCB} = 3.3\text{ V}$, RL=54 Ω	-	57.5	95	mA
CMTI	Common-mode transient immunity	$V_{CM} = 1200\text{ V}$	-	100	150	-	kV/ μs

(1) Parameters are provided by lab bench test and design simulation.

Switching Characteristics

All test conditions: $V_{CCA} = 2.25\text{ V TO } 5.5\text{ V}$, $V_{CCB} = 3\text{ V to } 5.5\text{ V}$, $T_A = -40^\circ\text{C to } 125^\circ\text{C}$, 500Kbps, unless otherwise noted.

Parameter	Conditions	Min	Typ	Max	Units		
Driver							
t_r, t_f	Driver Differential-Output Rise and fall times ⁽¹⁾	-	470	700	ns		
t_{PHL}, t_{PLH}	Driver Propagation Delay	-	460	700			
$t_{SK(P)}$	Driver Pulse Skew, $ t_{PHL} - t_{PLH} $ ⁽¹⁾	-	6				
t_{PHZ}, t_{PLZ}	Driver disable time	/RE = 0 or V_{CCA}		-	75	200	ns
t_{PZH}, t_{PZL}	Driver Enable Time	-	350	1000	ns		
Receiver							
t_r, t_f	Driver Differential-Output Rise and Fall Times ⁽¹⁾	-	2	4	ns		
t_{PHL}, t_{PLH}	Receiver Propagation Delay Time	$C_L = 15\text{ pF}$		-	115	220	ns
$t_{SK(P)}$	Receiver Pulse Skew, $ t_{PHL} - t_{PLH} $ ⁽¹⁾	-	5				
t_{PHZ}, t_{PLZ}	Receiver Disable Time	DE = 0 or V_{CCA}		-	35	60	ns
t_{PZH}, t_{PZL}	Receiver Enable Time	-	30	60	ns		

(1) Parameters are provided by lab bench test and design simulation.

Test Circuits and Waveforms

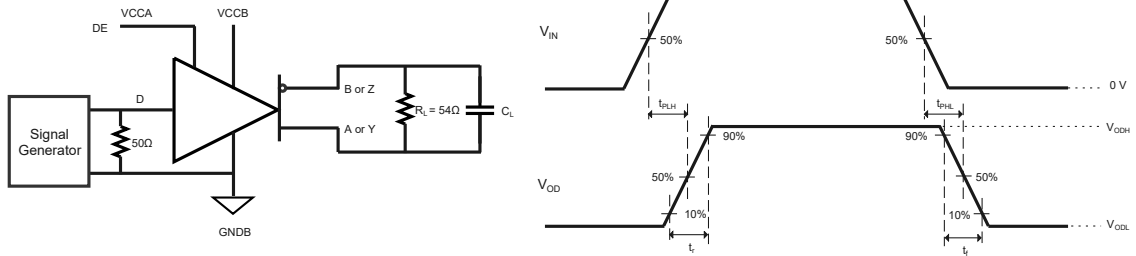

Figure 1. Driver Switching Test Circuit and Waveforms

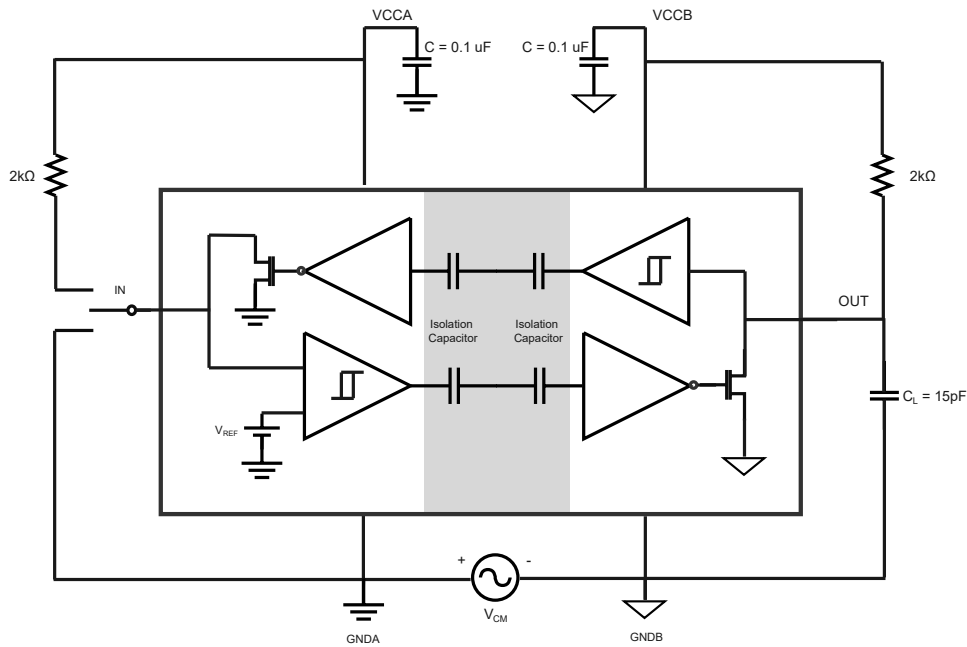

Figure 2. Common Mode Transient Immunity Test Circuit

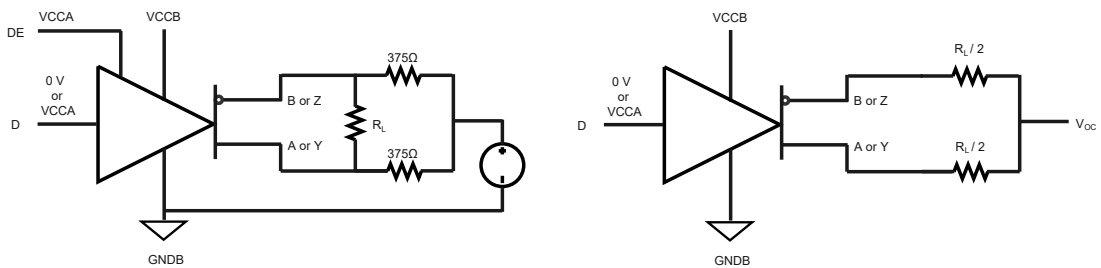

Figure 3. Driver Test Circuit

Isolated Full- and Half-Duplex RS485 Transceiver

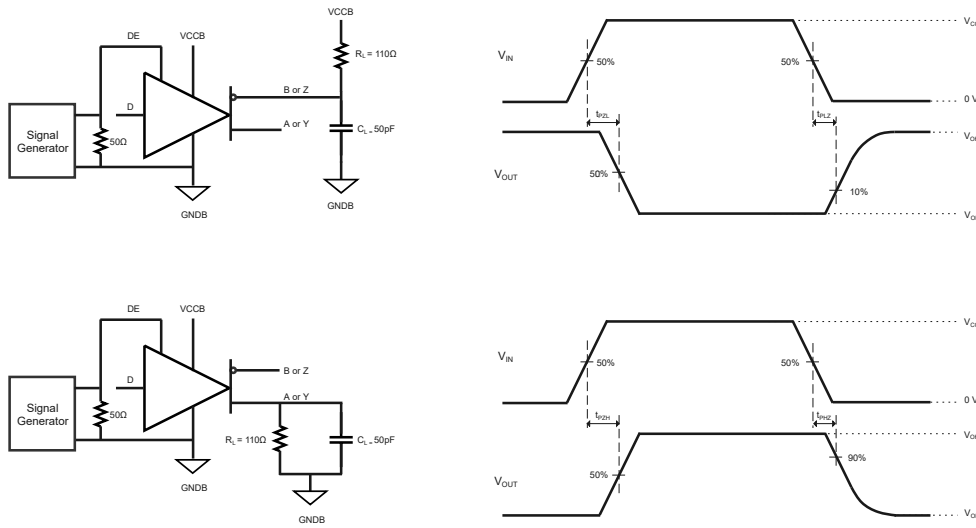

Figure 4. Driver Enable: Disable Propagation Delay Test Circuit and Waveforms

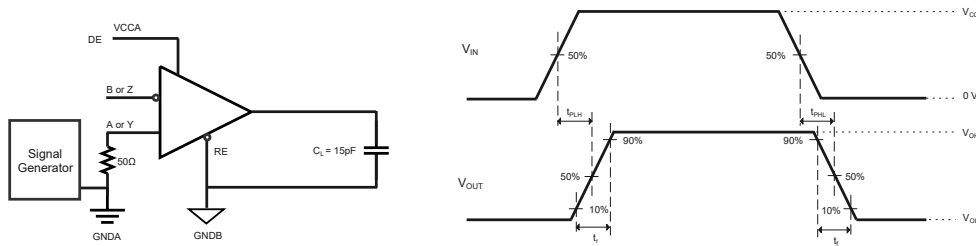

Figure 5. Receiver Switching Test Circuit and Waveforms

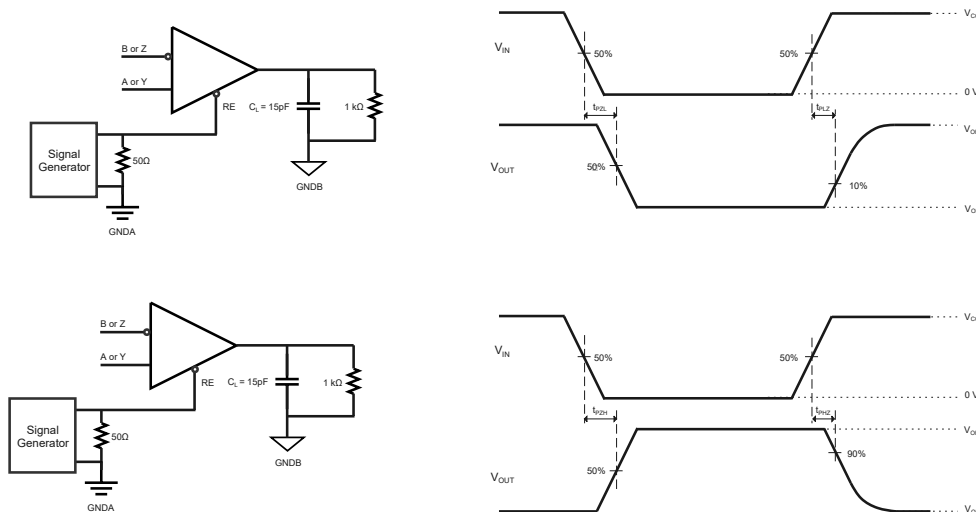

Figure 6. Receiver Enable: Disable Propagation Delay Test Circuit and Waveforms

Isolated Full- and Half-Duplex RS485 Transceiver

Detailed Description

Overview

The TPT748x features a fail-safe receiver, which supports the output of the receiver to be logic high when the differential input (bus pin A/B) of the receiver is open, short, or idle when $RXP = 0\text{ V}$.

Transmitters in this family deliver exceptional differential output voltages into the RS-485 required $54\text{-}\Omega$ load. The 500-kbps device has very low bus currents, so they present a true “1/8 unit load” to the RS-485 bus. This allows up to 256 transceivers on the network without using repeaters. Receiver (Rx) inputs feature a “Full Fail-Safe” design, which ensures a logic-high Rx output if Rx inputs are floating, shorted, or on a terminated but undriven bus.

Functional Block Diagram

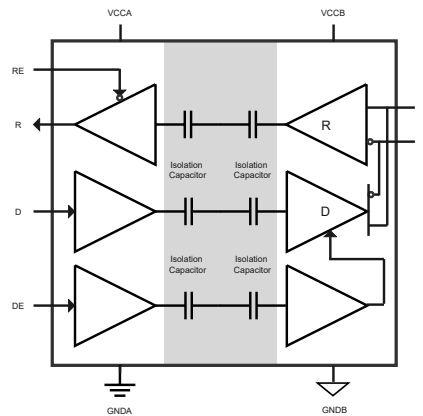

Figure 7. TPT7487 Block Diagram

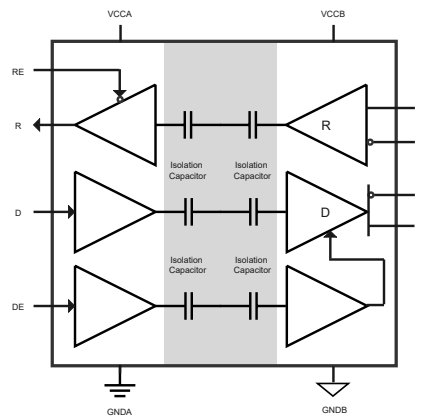

Figure 8. TPT7488 Block Diagram

Feature Description
Table 3. Driver Function Table

Input	Enable	Output	Output	Description
D	DE	A	B	
H	H	H	L	Actively drives bus High
L	H	L	H	Actively drives bus Low
X	L	Z	Z	Driver disabled
X	OPEN	Z	Z	Driver disabled by default
Open	H	H	L	Actively drives bus High by default

(1) X = don't care

(2) Z = high impedance

Table 4. Receiver Function Table

Input	Input	Output	Description
A-B	/RE	R	
> -50mV	L	H	Receive valid bus High
-200 mV < Input < -50 mV	L	?	Indeterminate bus state
< -200 mV	L	L	Receive valid bus Low
X	H	Z	Receiver disabled
X	OPEN	Z	Receiver disabled in default
Open	L	H	Fail-safe high output
Short	L	H	Fail-safe high output
Idle (Terminated)	L	H	Fail-safe high output

(1) X = don't care

(2) Z = high impedance

Tape and Reel Information

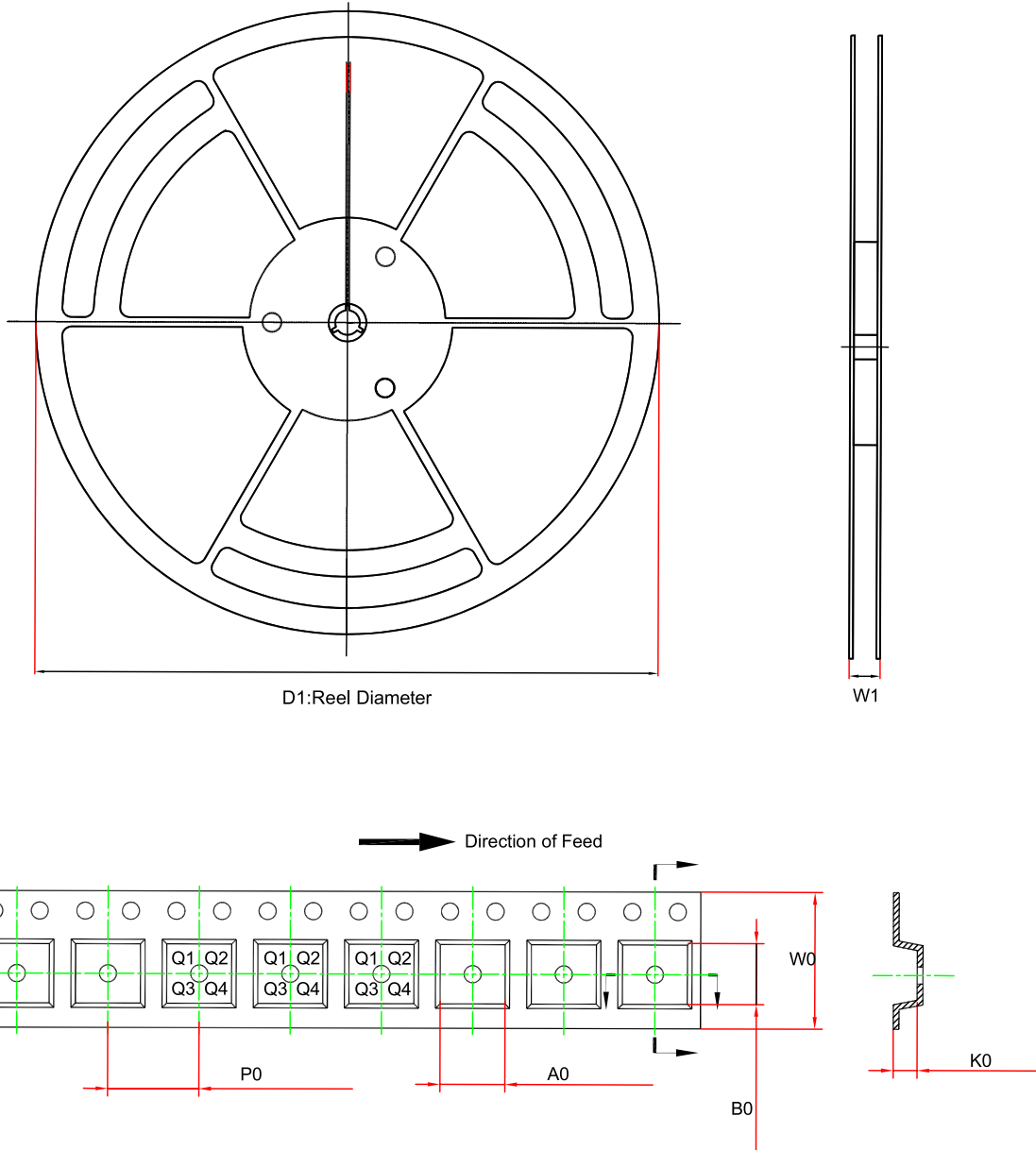

Order Number	Package	D1 (mm)	W1 (mm)	A0 (mm)	B0 (mm)	K0 (mm)	P0 (mm)	W0 (mm)	Pin1 Quadrant
TPT7487-SOBR	WSOP16	330	21.6	10.9	10.8	3.0	12.0	16.0	Q1
TPT7488-SOBR	WSOP16	330	21.6	10.9	10.8	3.0	12.0	16.0	Q1

Package Outline Dimensions

WSOP16

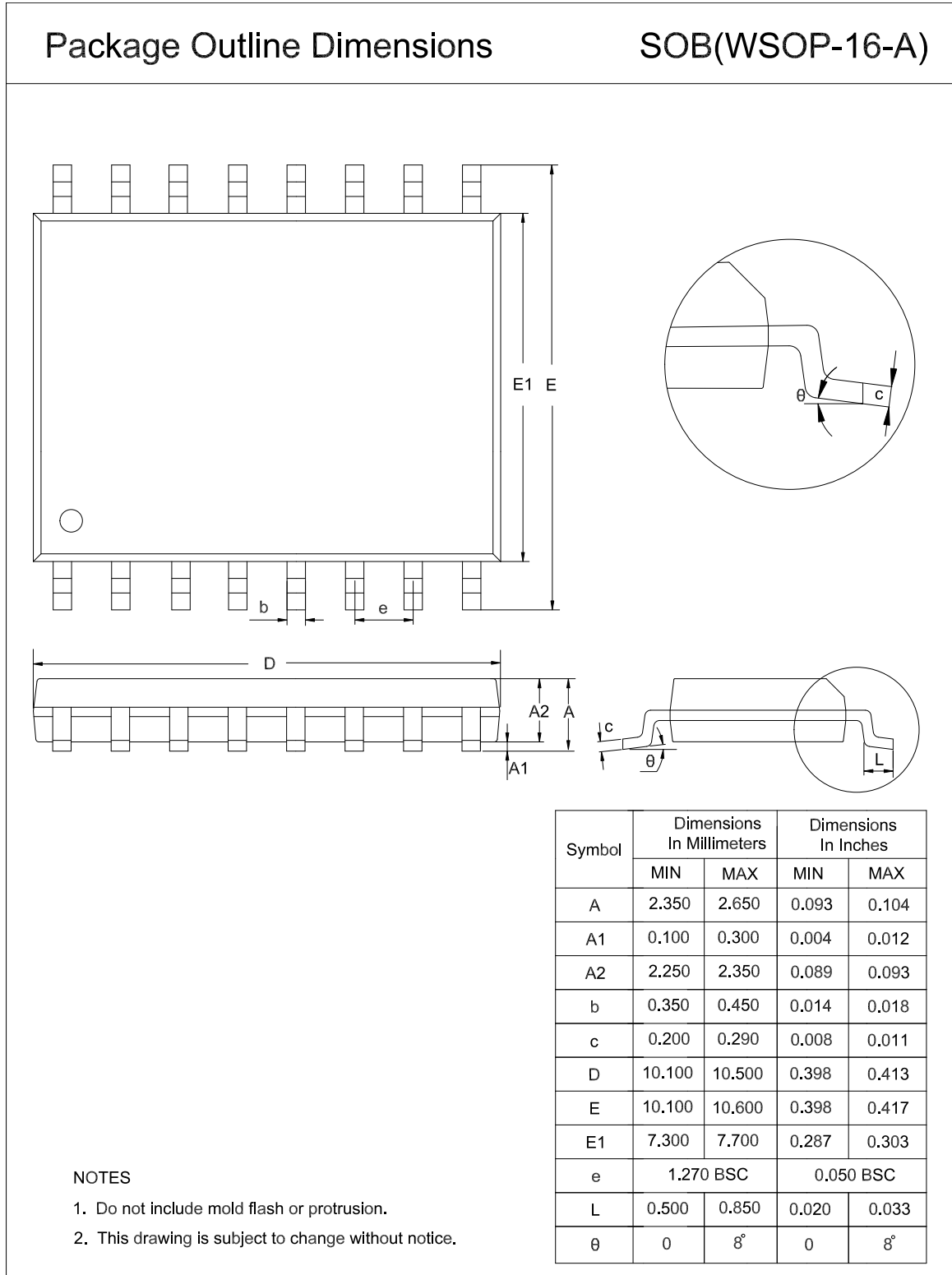

Order Information

Order Number	Operating Temperature Range	Package	Marking Information	MSL	Transport Media, Quantity	Eco Plan
TPT7487-SOBR	-40 to 125°C	WSOP16	T7487	MSL3	Tape and Reel, 1500	Green
TPT7488-SOBR	-40 to 125°C	WSOP16	T7488	MSL3	Tape and Reel, 1500	Green

Green: 3PEAK defines "Green" to mean RoHS compatible and free of halogen substances.

IMPORTANT NOTICE AND DISCLAIMER

Copyright© 3PEAK 2012-2023. All rights reserved.

Trademarks. Any of the 思瑞浦 or 3PEAK trade names, trademarks, graphic marks, and domain names contained in this document /material are the property of 3PEAK. You may NOT reproduce, modify, publish, transmit or distribute any Trademark without the prior written consent of 3PEAK.

Performance Information. Performance tests or performance range contained in this document/material are either results of design simulation or actual tests conducted under designated testing environment. Any variation in testing environment or simulation environment, including but not limited to testing method, testing process or testing temperature, may affect actual performance of the product.

Disclaimer. 3PEAK provides technical and reliability data (including data sheets), design resources (including reference designs), application or other design recommendations, networking tools, security information and other resources "As Is". 3PEAK makes no warranty as to the absence of defects, and makes no warranties of any kind, express or implied, including without limitation, implied warranties as to merchantability, fitness for a particular purpose or non-infringement of any third-party's intellectual property rights. Unless otherwise specified in writing, products supplied by 3PEAK are not designed to be used in any life-threatening scenarios, including critical medical applications, automotive safety-critical systems, aviation, aerospace, or any situations where failure could result in bodily harm, loss of life, or significant property damage. 3PEAK disclaims all liability for any such unauthorized use.