

Features

- Bidirectional Translator of 1:4 I²C Switch
- Active-Low Reset Input
- Two Address Terminals, Allowing up to Four Devices on the I²C Bus
- Operating Power-Supply Voltage Range of 2.3 to 5.5V
- Allow Voltage-Level Translation among 2.5V, 3.3V, and 5V Buses
- Support Standard Mode and Fast Mode I²C Devices, 0 to 400 kHz Clock Frequency
- Low RON Switches
- Latch-Up Performance Exceeds 200 mA per JESD 78
- ESD Protection Exceeds JESD 22
 - ±4000V Human-Body Model
 - ±1500V Charged-Device Model

Applications

- Servers/Storages
- Routers (Telecom Switching Equipment)
- Factory Automation
- Products with I²C Slave Address Conflicts (e.g. Multiple, Identical Temp Sensors)

Description

The TPT29546 is a 1:4 bidirectional translating I²C switch. The SCL/SDA upstream pair fans out to four downstream channels. Any single SCn/SDn channel or combination of channels can be selected, determined by the programmable control register.

If one of the downstream I²C buses is stuck in a low state, then an active-low reset ($\overline{\text{RESET}}$) input helps the TPT29546 to recover. Pulling $\overline{\text{RESET}}$ low resets the I²C state machine and causes all the channels to be deselected, as does the internal power-on reset function.

The pass gates of the switches are constructed such that the VCC terminal can be used to limit the maximum high voltage, which will be passed by the TPT29546. This allows the use of different bus voltages on each pair, so that 2.5V, or 3.3V parts can communicate with 5V parts, without any additional protection. External pull-up resistors pull the bus up to the desired voltage level for each channel. All I/O terminals are 5.5 V tolerant.

TPT29546 is available in the TSSOP16 and SOP16 package, and is characterized from -40°C to +85°C.

Typical Application Circuit

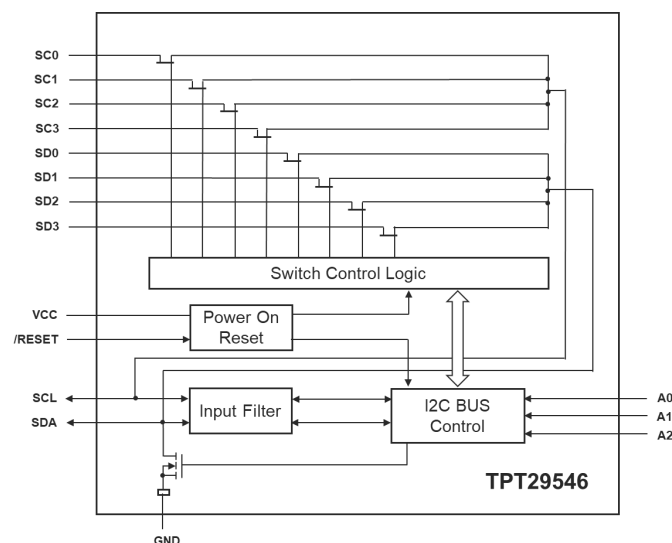

Table of Contents

Features	1
Applications	1
Description	1
Typical Application Circuit	1
Revision History	3
Pin Configuration and Functions	4
Specifications	5
Absolute Maximum Ratings ⁽¹⁾	5
Recommended Operating Conditions	5
ESD Electrostatic Discharge Protection	5
Thermal Information	5
Electrical Characteristics – DC Parameters	6
Electrical Characteristics – AC Parameters	8
Switching Characteristics	9
Parameter Measurement Waveforms	9
Detailed Description	10
Overview.....	10
Functional Block Diagram	10
Application and Implementation	11
Application Information	11
Tape and Reel Information	13
Package Outline Dimensions	14
Order Information	16
IMPORTANT NOTICE AND DISCLAIMER	17

Revision History

Date	Revision	Notes
2022/06/10	Rev. Pre. 0	Initial Version
2022/09/18	Rev. Pre. 1	Preliminary version; added typical electrical data
2022/12/06	Rev. A.0	Released version

Pin Configuration and Functions

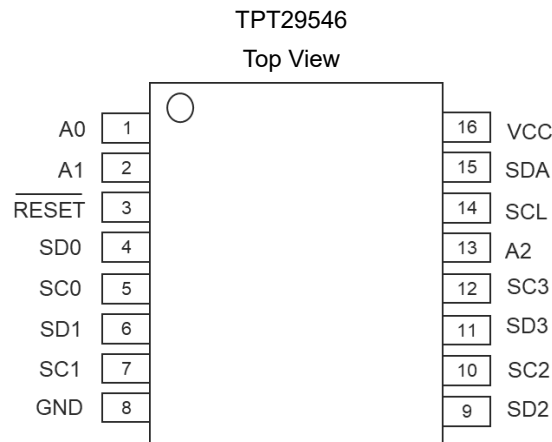

Table 1. Pin Functions: TPT29546

Pin	Name	I/O	Description
1	A0	Input	Address input 0. Connect directly to V _{CC} or ground.
2	A1	Input	Address input 1. Connect directly to V _{CC} or ground.
3	$\overline{\text{RESET}}$	Input	Active-low reset input. Connect to V _{CC} through a pull-up resistor if not used.
4	SD0	I/O	Serial data 0. Connect to the power of slave channel 0 through a pull-up resistor
5	SC0	I/O	Serial clock 0. Connect to the power of slave channel 0 through a pull-up resistor
6	SD1	I/O	Serial data 1. Connect to the power of slave channel 1 through a pull-up resistor
7	SC1	I/O	Serial clock 1. Connect to the power of slave channel 1 through a pull-up resistor
8	GND	GND	Ground
9	SD2	I/O	Serial data 2. Connect to the power of slave channel 0 through a pull-up resistor
10	SC2	I/O	Serial clock 2. Connect to the power of slave channel 0 through a pull-up resistor
11	SD3	I/O	Serial data 3. Connect to the power of slave channel 0 through a pull-up resistor
12	SC3	I/O	Serial clock 3. Connect to the power of slave channel 0 through a pull-up resistor
13	A2	Input	Address input 2. Connect directly to V _{CC} or ground.
14	SCL	I/O	Clock bus. Connect to V _{CC} through a pull-up resistor
15	SDA	I/O	Data bus. Connect to V _{CC} through a pull-up resistor
16	VCC	Supply	Supply power

Specifications

Absolute Maximum Ratings⁽¹⁾

Parameters		Condition	Min	Max	Unit
V _{CC}	Supply Voltage		-0.5	7	V
V _I	Input Voltage		-0.5	7	V
I _{IK}	Input Clamp Current	V _I < 0		±20	mA
I _{OK}	Output Clamp Current	V _O < 0		±25	mA
I _{CC}	Continuous Current through GND			±100	mA
T _J	Maximum Junction Temperature			125	°C
T _A	Operating Temperature Range		-45	85	°C
T _{stg}	Storage Temperature		-60	150	°C

(1) Stresses beyond those listed under Absolute Maximum Ratings may cause permanent damage to the device. Exposure to any Absolute Maximum Rating condition for extended periods may affect device reliability and lifetime.

Recommended Operating Conditions

Parameters		Condition	Min	Max	Unit
V _{CC}	Supply Voltage		2.3	5.5	V
V _{IH}	High-level Input Voltage	SCL, SDA	0.7 × V _{CC}	5.5	V
		A1,A0, /RESET	0.7 × V _{CC}	5.5	V
V _{IL}	Low-level Input Voltage	SCL, SDA	-0.5	0.3 × V _{CC}	mA
		A1,A0, /RESET	-0.5	0.3 × V _{CC}	mA
T _A	Operating Temperature Range		-40	85	°C

ESD Electrostatic Discharge Protection

Parameter		Condition	Minimum Level	Unit
HBM	Human Body Model ESD	ANSI/ESDA/JEDEC JS-001	±4	kV
CDM	Charged Device Model ESD	ANSI/ESDA/JEDEC JS-002	±1.5	kV

Thermal Information

Package Type	θ _{JA}	θ _{JC}	Unit
TSSOP16	125	61	°C/W
TSSOP16	97	55	°C/W

Electrical Characteristics – DC Parameters

All test condition is VCC = 2.3V~3.6V, TA = -40 ~ +85°C, unless otherwise noted.

Parameter	Conditions	Min	Typ	Max	Unit	
Supply						
IDD	Supply Current in Operating Mode	VCC= 3.6 V; no load; VI = VCC or GND; f _{SCL} = 100 kHz	-	2.4	20	uA
		VCC= 3.6 V; no load; VI = VCC or GND; f _{SCL} = 400 kHz	-	6.5	30	uA
Istb	Standby Current	VCC = 3.6 V; no load; VI = VCC or GND	-	0.9	3.0	uA
V _{POR}	Power-on Reset Voltage, VCC rising	no load; VI = VCC or GND	-	1.2	1.45	V
	Power-on Reset Voltage, VCC falling		0.8	1.2		V
Input SCLx; Input/output SDAx						
VIL	Low-level Input Voltage	VCC=2.3V			0.3VCC	V
VIH	High-level Input Voltage	VCC=2.3V	0.7VCC			V
IOL	Low-level Output Current	VCC=2.3V, VOL = 0.4 V	3	10		mA
	Low-level Output Current	VCC=2.3V, VOL = 0.6 V	6	13		mA
IL	Leakage Current	VCC=2.3V, VI = VCC or GND	-1	0.1	1	uA
C _i	Input Capacitance ⁽¹⁾	VI = GND		15		pF
Select Inputs A0,A1, /RESET						
VIL	Low-level Input Voltage	VCC=2.3V			0.3VCC	V
VIH	High-level Input Voltage	VCC=2.3V	0.7VCC			V
ILI	Input Leakage Current	VCC=2.3V, pin at VCC or GND	-1	0.1	1	uA
C _i	Input Capacitance ⁽¹⁾	VI = GND		3		pF
Pass Gate						
Ron	ON-state Resistance	VCC = 3.0 V to 3.6 V; VO = 0.4V; IO = 15 mA	0	4.8	25	Ω
		VCC = 2.3 V to 2.7 V; VO = 0.4V; IO = 10 mA	0	6.5	30	Ω
Vo(sw)	Switch Output Voltage ⁽¹⁾	Vi(sw) = VCC = 3.0 V to 3.6 V; Io(sw) = -100 uA	1.6	2.1	2.8	V
		Vi(sw) = VCC = 2.3 V to 2.7 V; Io(sw) = -100 uA	1.0	1.5	2.0	V
IL	Leakage Current	VI = VCC or GND	-1	0.1	1	uA
Cio	Input/output Capacitance ⁽¹⁾	VI = GND		3		pF

(1) Parameters are provided by lab bench test and design simulation

Electrical Characteristics – DC Parameters (Continued)

All test condition is VCC = 4.5V~5.5V, TA = -40 ~ +85°C, unless otherwise noted.

Parameter	Conditions	Min	Typ	Max	Unit	
Supply						
IDD	Supply Current in Operating Mode	VCC= 5.5 V; no load; VI = VCC or GND; f _{SCL} = 100 kHz	-	5	20	uA
		VCC= 5.5 V; no load; VI = VCC or GND; f _{SCL} = 400 kHz		14	30	uA
Istb	Standby Current	VCC = 5.5 V; no load; VI = VCC or GND	-	1.8	3.0	uA
V _{POR}	Power-on Reset Voltage rising	no load; VI = VCC or GND	-	1.25	1.45	V
	Power-on Reset Voltage falling		0.8	1.2		V
Input SCL; Input/output SDA						
V _{IL}	Low-level Input Voltage ⁽¹⁾	VCC=5.5V			0.3VCC	V
V _{IH}	High-level Input Voltage	VCC=5.5V	0.7VCC			V
I _{OL}	Low-level Output Current	VCC=5.5V, VOL = 0.4 V	3	22		mA
	Low-level Output Current	VCC=5.5V, VOL = 0.6 V	6	32		mA
I _L	Leakage Current	VI = VCC or GND	-1	0.1	1	uA
C _i	Input Capacitance ⁽¹⁾	VI = GND		15		pF

(1) Parameters are provided by lab bench test and design simulation

Electrical Characteristics – DC Parameters (Continued)

All test condition is VCC = 4.5V~5.5V, TA = -40 ~ +85°C, unless otherwise noted.

Parameter	Conditions	Min	Typ	Max	Unit	
Select inputs A0 to A2, /RESET						
V _{IL}	Low-level Input Voltage	VCC=5.5V			0.3VCC	V
V _{IH}	High-level Input Voltage	VCC=5.5V	0.7VCC			V
I _{LI}	Input Leakage Current	pin at VCC or GND	-1	0.1	1	uA
C _i	Input Capacitance ⁽¹⁾	VI = GND		3		pF
Pass gate						
R _{on}	ON-state Resistance	VCC = 4.5 V to 5.5 V; VO = 0.4 V; IO = 15 mA	1	3.3	20	Ω
V _{o(sw)}	Switch Output Voltage ⁽¹⁾	Vi(sw) = VCC = 4.5 V to 5.5 V; Io(sw) = -100 uA	2.6	3.55	4.5	V
I _L	Leakage Current	VI = VCC or GND	-1	0.1	1	uA
C _{io}	Input/output Capacitance ⁽¹⁾	VI = GND		3		pF

(1) Parameters are provided by lab bench test and design simulation

Electrical Characteristics – AC Parameters

I²C Interface Timing Requirements

Over recommended operating free-air temperature range (unless otherwise noted)

Parameter		Condition	Min	Max	Unit
I ² C BUS—Fast Mode					
fscL	I ² C Clock Frequency		0	400	kHz
tsch	I ² C Clock High Time		0.6		μs
tscl	I ² C Clock Low Time		1.3		μs
tsp	I ² C Spike Time			50	ns
tsds	I ² C Serial Data Setup Time		100		ns
tsdh	I ² C Serial Data Hold Time		0		ns
ticr	I ² C Input Rise Time		20	300	ns
ticf	I ² C Input Fall Time		20+0.1Cb	300	ns
toCF	I ² C Output Fall Time ⁽¹⁾	10-pF to 400-pF bus	20+0.1Cb	300	ns
tbuf	I ² C bus free time between stop and start		1.3		μs
tsts	I ² C start or repeated start condition setup		0.6		μs
tsth	I ² C start or repeated start condition hold		0.6		μs
tspS	I ² C Stop Condition Setup		0.6		μs
tvD(data)	Valid Data Time	SCL low to SDA output valid		0.9	μs
tvD(ack)	Valid Data Time of ACK Condition	ACK signal from SCL low to SDA (out) low		0.9	μs
tSP	pulse width of spikes that must be suppressed by the input filter			50	ns
tPD	Propagation Delay ⁽¹⁾	from SDA to SDx, or SCL to SCx		0.3	ns
C _b	I ² C Bus Capacitive Load			400	pF

(1) The propagation delay is calculated from the 20 typical Ron and the 15 pF load capacitance.

Switching Characteristics

Over recommended operating free-air temperature range, $C_L \leq 100$ pF (unless otherwise noted)

Parameter	Condition	Min	Max	Unit
T _{vd} ; DAT Data Valid Time	HIGH to LOW		1	μs
	LOW to HIGH		0.55	μs
T _{vd} ; DAT Data Valid Time Acknowledge Time			1	ns
/RESET				
t _{w(rst)L} Low-level Reset Time		4		ns
t _{rst} Reset Time	SDA clear		500	ns
t _{REC;STA} Recovery Time to START Condition		0		ns

(1) Parameters are provided by lab bench test and design simulation.

Parameter Measurement Waveforms

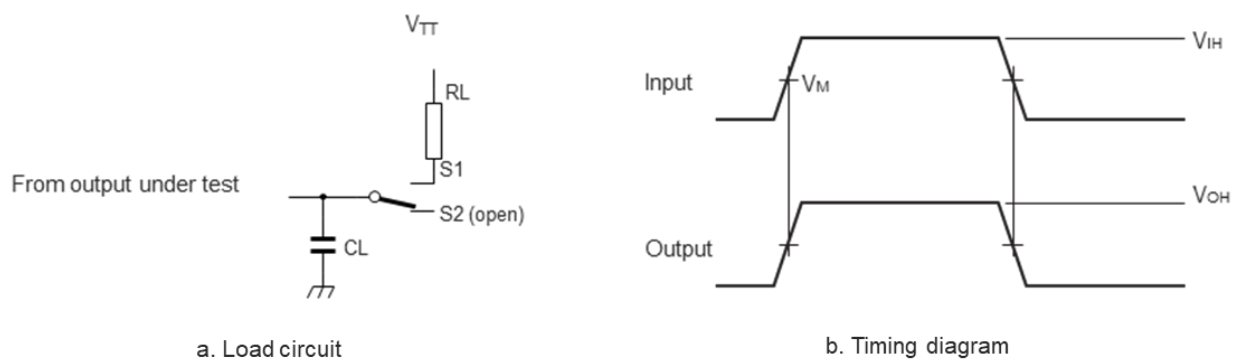

Figure 1. Load Circuit for Outputs

Detailed Description

Overview

The TPT29546 is a 1:4 bidirectional translating I²C switch. The SCL/SDA upstream pair fans out to four downstream channels. Any single SCn/SDn channel or combination of channels can be selected, determined by the programmable control register.

If one of the downstream I²C buses is stuck in a low state, then an active-low reset ($\overline{\text{RESET}}$) input helps the TPT29546 to recover. Pulling $\overline{\text{RESET}}$ low resets the I²C state machine and causes all the channels to be deselected, as does the internal power-on reset function.

Functional Block Diagram

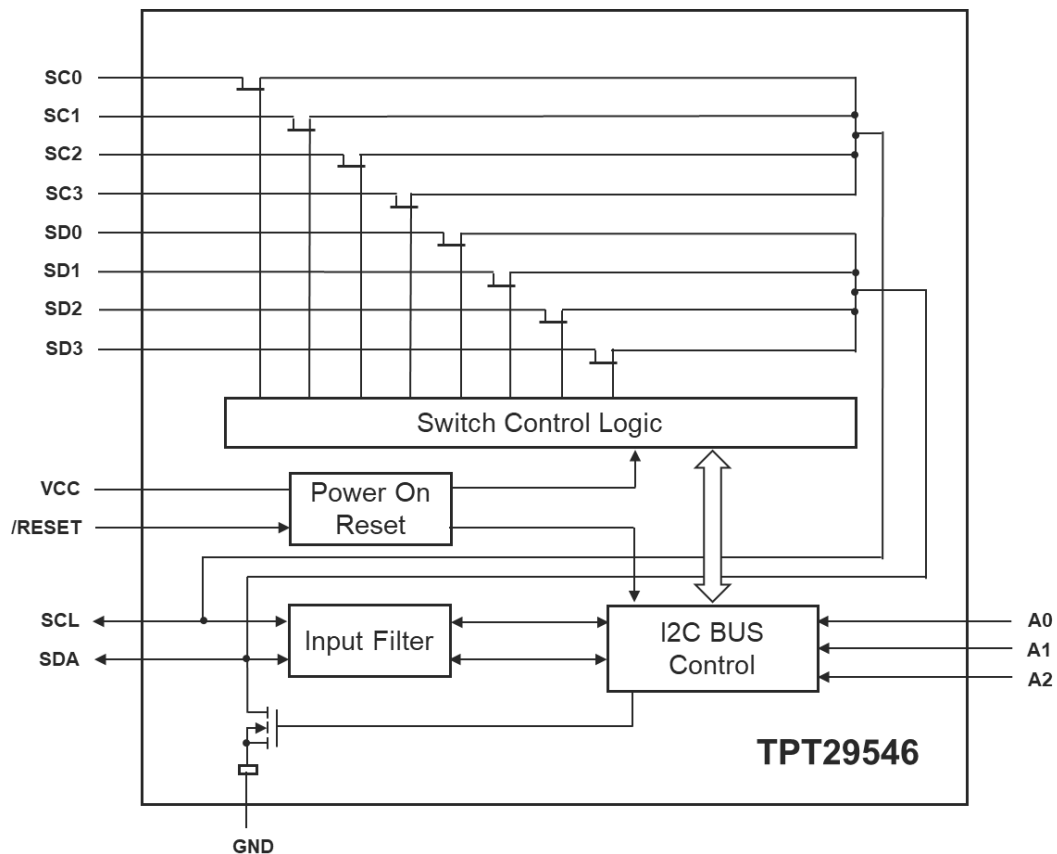

Figure 2. Functional Block Diagram

Application and Implementation

NOTE

Information in the following applications sections is not part of the 3PEAK's component specification and 3PEAK does not warrant its accuracy or completeness. 3PEAK's customers are responsible for determining suitability of components for their purposes. Customers should validate and test their design implementation to confirm system functionality.

Application Information

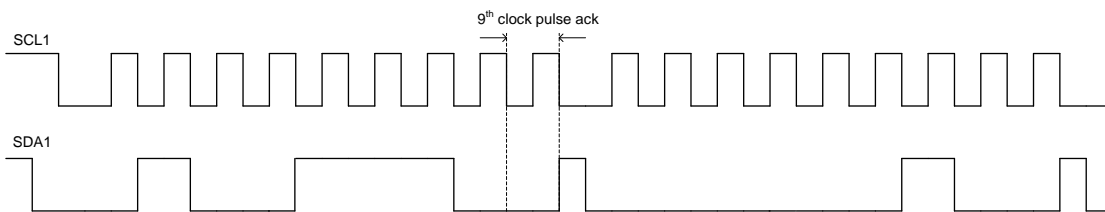

Figure 3. I²C BUS (2.3V~5.5V) Waveform

Device Address

Following a START condition, the bus master must output the address of the slave when it is accessing. To conserve power, no internal pull-up resistor is incorporated on the hardware selectable address pins and they must be pulled HIGH or LOW. The address of the TPT29546 is shown below.

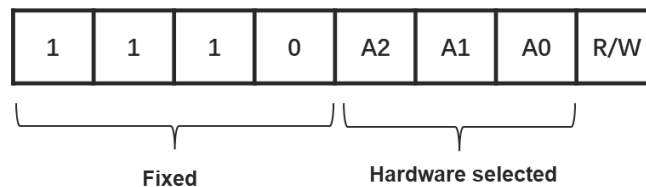

Figure 4. Slave Device Address

Control Register

Following the successful acknowledgement of the slave address, the bus master will send a byte to the TPT29546, which will be stored in the control register. If multiple bytes are received by the TPT29546, it will save the last byte received. This register can be written and read via the I²C -bus.

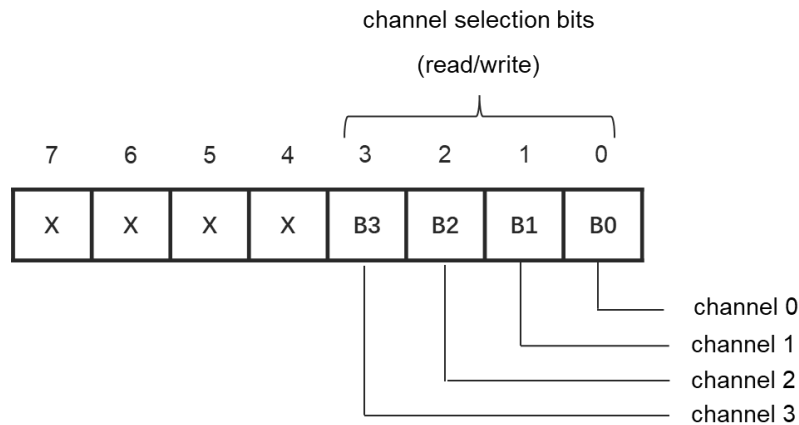

Figure 5. Control Register

Control Register Definition

One or several SCx/SDx downstream pair, or channel, is selected by the contents of the control register. This register is written after the TPT29546. The 4 LSBs of the control byte are used to determine which channel is to be selected. When a channel is selected, the channel will become active after a STOP condition has been placed on the I²C-bus. This ensures that all SCx/SDx lines are in a HIGH state when the channel is made active so that no false conditions are generated at the time of connection.

Control register: Write—channel selection; Read—channel status

B7	B6	B5	B4	B3	B2	B1	B0	Command
x	x	x	x	x	x	x	0	Channel 0 disable
x	x	x	x	x	x	x	1	Channel 0 enable
x	x	x	x	x	x	0	x	Channel 1 disable
x	x	x	x	x	x	1	x	Channel 1 enable
x	x	x	x	x	0	x	x	Channel 2 disable
x	x	x	x	x	1	x	x	Channel 2 enable
x	x	x	x	0	x	x	x	Channel 3 disable
x	x	x	x	1	x	x	x	Channel 3 enable
0	0	0	0	0	0	0	0	no channel selected; power-up/reset default state

Remark: Multiple channels can be enabled at the same time. Example: B3 = 0, B2 = 1, B1 = 1, B0 = 0, means that channel 0 and channel 3 are disabled and channel 1 and channel 2 are enabled. Care should be taken not to exceed the maximum bus capacitance.

Tape and Reel Information

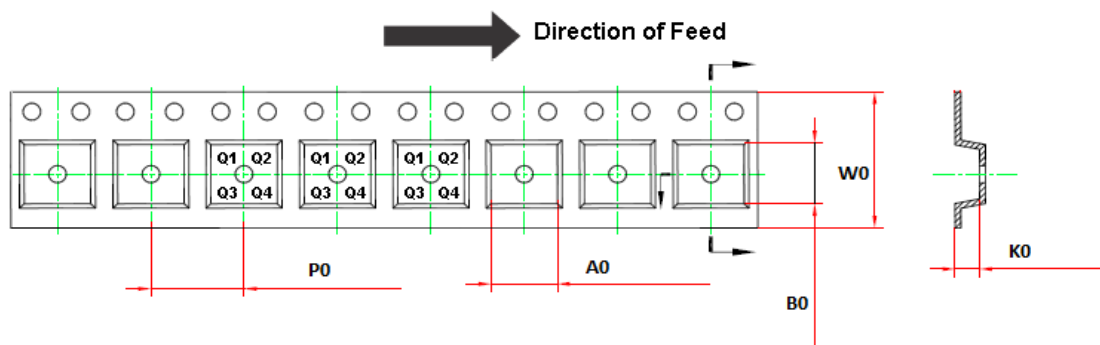
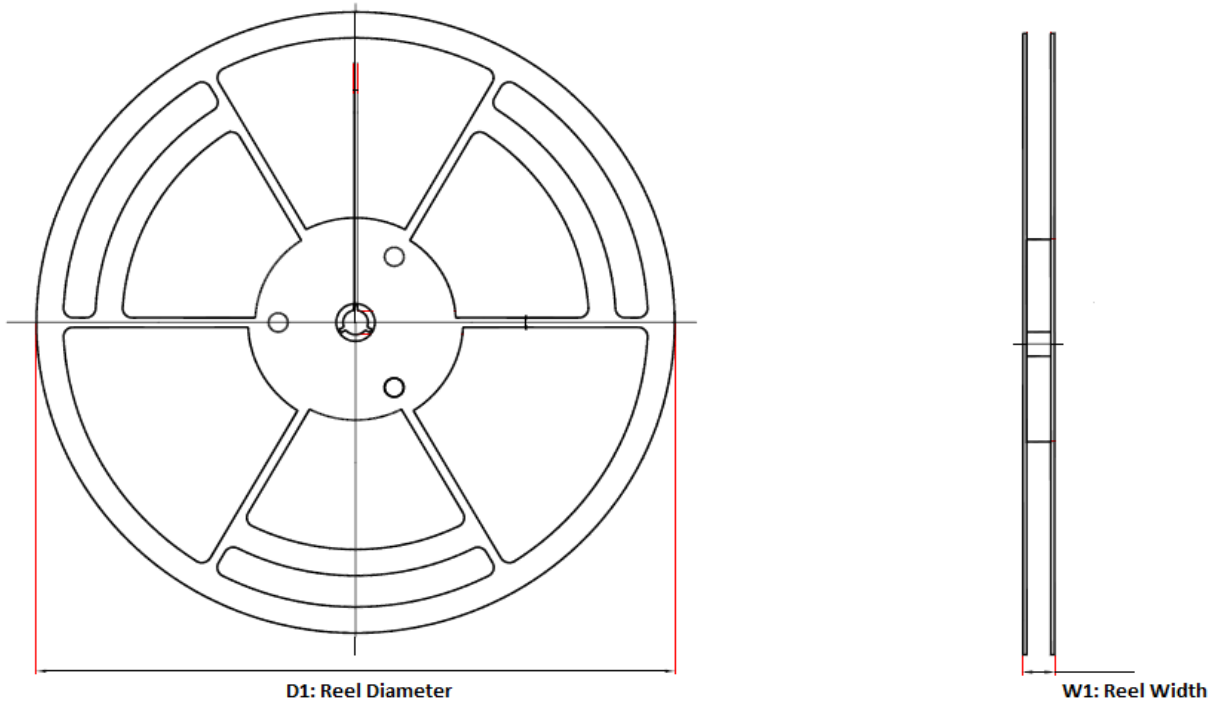

Order Number	Package	D1 (mm)	A0 (mm)	K0 (mm)	W0 (mm)	W1 (mm)	B0 (mm)	P0 (mm)	Pin1 Quadrant
TPT29546A-TS3R	TSSOP16	330	6.8	1.3	12	17.6	5.4	8	Q1
TPT29546A-SO3R	SOP16	330	6.7	2.1	16	21.6	10.4	8	Q1

Package Outline Dimensions

TSSOP16 (-TS3R)

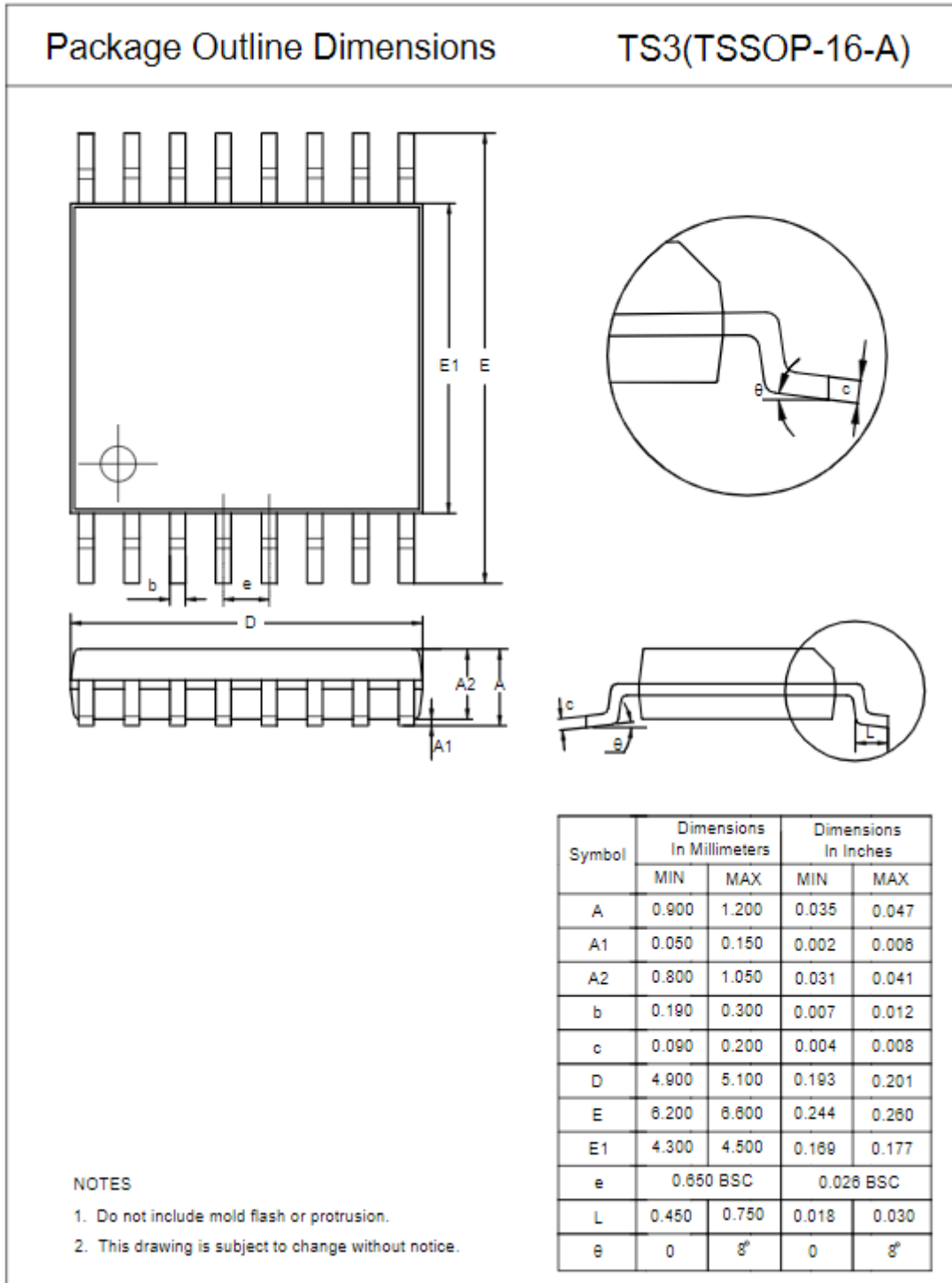

Package Outline Dimensions

SOP16 (-SO3R)

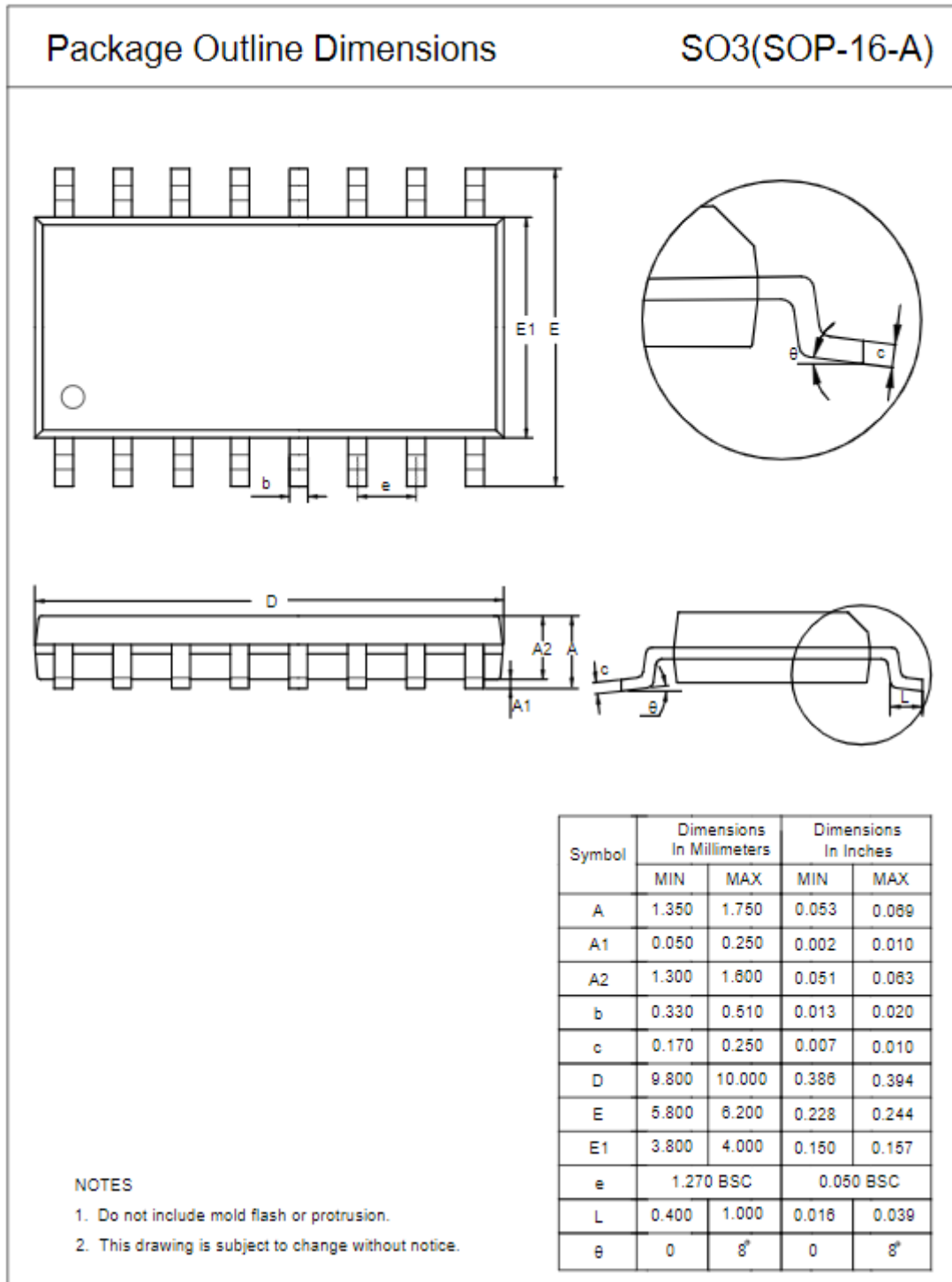

Order Information

Order Number	Operating Temperature Range	Package	Marking Information	MSL	Transport Media, Quantity	Eco Plan
TPT29546A-TS3R	-40 to 85°C	16-Pin TSSOP	9546A	MSL3	3,000	Green
TPT29546A-SO3R ⁽²⁾	-40 to 85°C	16-Pin SOP	9546A	MSL3	2,500	Green

(1) Green: 3PEAK defines "Green" to mean RoHS compatible and free of halogen substances.

(2) Future product, contact 3PEAK factory for more information and sample

IMPORTANT NOTICE AND DISCLAIMER

Copyright© 3PEAK 2012-2023. All rights reserved.

Trademarks. Any of the 思瑞浦 or 3PEAK trade names, trademarks, graphic marks, and domain names contained in this document /material are the property of 3PEAK. You may NOT reproduce, modify, publish, transmit or distribute any Trademark without the prior written consent of 3PEAK.

Performance Information. Performance tests or performance range contained in this document/material are either results of design simulation or actual tests conducted under designated testing environment. Any variation in testing environment or simulation environment, including but not limited to testing method, testing process or testing temperature, may affect actual performance of the product.

Disclaimer. 3PEAK provides technical and reliability data (including data sheets), design resources (including reference designs), application or other design recommendations, networking tools, security information and other resources "As Is". 3PEAK makes no warranty as to the absence of defects, and makes no warranties of any kind, express or implied, including without limitation, implied warranties as to merchantability, fitness for a particular purpose or non-infringement of any third-party's intellectual property rights. Unless otherwise specified in writing, products supplied by 3PEAK are not designed to be used in any life-threatening scenarios, including critical medical applications, automotive safety-critical systems, aviation, aerospace, or any situations where failure could result in bodily harm, loss of life, or significant property damage. 3PEAK disclaims all liability for any such unauthorized use.