

Features

- Qualified for Automotive Applications
 - AEC-Q100 Grade 1, T_A : -40°C to $+125^{\circ}\text{C}$
 - Junction Temperature, T_J : -40°C to $+150^{\circ}\text{C}$
- Wide Input Voltage Range
 - 3.2 V to 60 V, with 65 V Maximum Rating
 - -60 V Reverse Polarity Input Voltage, with -65 V Maximum Rating
- External NMOS Driver
 - Charge Pump with External Capacitor
 - Gate Driver for External N-Channel MOSFET
 - 20-mV V_{AK} for Regulated Conduction Mode
 - -11 -mV V_{AK} for Reverse Current Blocking
 - 2.3-A Peak Sink Current to Turn-off NMOS
- Low Quiescent Current
 - 0.4- μA Low Shutdown Current (EN = LOW)
 - 60- μA Operating Current (EN = HIGH)
- Protection
 - Input Reverse Polarity Protection
 - Fast Reverse Current Blocking: 700 ns Maximum
- Meets Automotive ISO 7637 Transient Requirements with a Suitable TVS Diode
- SOT23-6 Package

Applications

- Automotive Infotainment, Navigation, Telematics
- Automotive ADAS, Surround-View Cameras
- Automotive Cluster, Head Unit, HUD
- Industry Control, Factory Automation
- Enterprise Power Supply

Description

The TPS65R01Q is an ideal diode controller that operates with an external N-channel MOSFET for reverse protection in automotive. The forward voltage drop is controlled at as low as 20 mV, which could significantly reduce power loss compared to an ordinary Schottky Diode.

The TPS65R01Q supports a wide operating voltage range from 3.2 V to 60 V, with an absolute maximum rating of 65 V. The support for a 3.2-V input voltage is particularly suitable to meet the severe cold crank requirement in automotive systems. Moreover, this device can withstand a -60 V reverse voltage, with an absolute maximum rating of -65 V.

The TPS65R01Q integrates a charge pump to drive the external N-channel MOSFET. The device provides a precise gate control to regulate the voltage drop between the source and drain at 20 mV. When it detects a reverse voltage of -11 mV from ANODE (A) to CATHODE (K), the TPS65R01Q will turn off the external MOSFET within 700 ns maximum to ensure no reverse current flows.

The above features make the TPS65R01Q suitable for different conditions in various automotive applications.

The TPS65R01Q provides a small SOT23-6 package, and it is qualified with AEC-Q100 Grade 1 to operate within the ambient temperature range from -40°C to $+125^{\circ}\text{C}$.

Typical Application Circuit

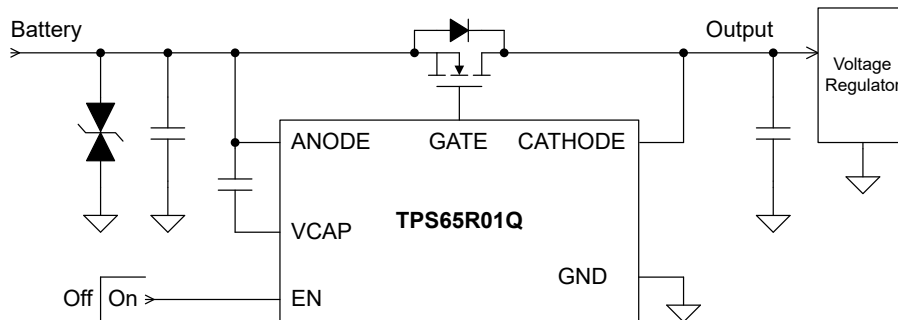

Table of Contents

Features	1
Applications	1
Description	1
Typical Application Circuit	1
Product Family Table	3
Revision History	3
Pin Configuration and Functions	4
Specifications	5
Absolute Maximum Ratings ⁽¹⁾	5
ESD, Electrostatic Discharge Protection.....	5
Recommended Operating Conditions.....	5
Thermal Information.....	6
Electrical Characteristics.....	7
Typical Performance Characteristics.....	9
Detailed Description	13
Overview.....	13
Functional Block Diagram.....	13
Feature Description.....	14
Application and Implementation	16
Application Information	16
Typical Application.....	16
Layout	19
Layout Guideline.....	19
Layout Example.....	19
Tape and Reel Information	20
Package Outline Dimensions	21
SOT23-6.....	21
Order Information	22
IMPORTANT NOTICE AND DISCLAIMER	23

Product Family Table

Order Number	Maximum Voltage Range (V)	Operating Voltage Range (V)	Package
TPS65R01Q-S6TR-S	-65 to 65	3.2 to 60	SOT23-6

Revision History

Date	Revision	Notes
2023-09-30	Rev.Pre.0	Preliminary datasheet.
2024-03-31	Rev.Pre.1	Added Typical Performance Characteristics , Functional Block Diagram , and Feature Description .
2024-05-31	Rev.A.0	Initial Released.

Pin Configuration and Functions

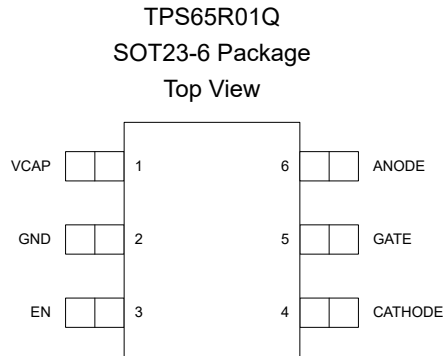

Table 1. Pin Functions: TPS65R01Q

Pin No.	Pin Name	I/O	Description
6	ANODE	I	Anode pin of the diode. Connect this pin to the source of the external N-channel MOSFET.
4	CATHODE	I	Cathode pin of the diode. Connect this pin to the drain of the external N-channel MOSFET.
3	EN	I	Enable pin. Connect this pin to HIGH for normal operation, and connect this pin to LOW to enter the standby mode.
5	GATE	O	Gate drive output pin. Connect this pin to the gate of the external N-channel MOSFET.
2	GND	-	Ground reference pin.
1	VCAP	O	Charge pump output pin. Connect this pin to the ANODE pin through an external capacitor.

Automotive 65-V Reverse Protection Ideal Diode Controller

Specifications

Absolute Maximum Ratings ⁽¹⁾

Parameter		Min	Max	Unit
ANODE to GND		-65	65	V
EN to GND, VANODE > 0 V		-0.3	65	V
EN to GND, VANODE ≤ 0 V		V _{ANODE}	65 + V _{ANODE}	V
GATE to ANODE		-0.3	15	V
VCAP to ANODE		-0.3	15	V
CATHODE to ANODE		-5	75	V
T _J	Junction Temperature Range	-40	150	°C
T _A	Ambient Temperature Range	-40	125	°C
T _{STG}	Storage Temperature Range	-65	150	°C
T _L	Lead Temperature (Soldering 10 sec)		260	°C

(1) Stresses beyond those listed under Absolute Maximum Ratings may cause permanent damage to the device. Exposure to any Absolute Maximum Rating condition for extended periods may affect device reliability and lifetime.

(2) All voltage values are with respect to GND.

(3) Not subject to production test, specified by design.

ESD, Electrostatic Discharge Protection

Parameter		Condition	Minimum Level	Unit
HBM	Human Body Model ESD	AEC Q100-002	±2	kV
CDM	Charged Device Model ESD	AEC Q100-011	±2	kV

Recommended Operating Conditions

Parameter		Min	Max	Unit
V _{ANODE}	ANODE to GND	-60	60	V
V _{CATHODE}	CATHODE to GND		60	V
V _{EN}	EN to GND	-60	60	V
V _{AK}	ANODE (A) to CATHODE (K)	-70		V
V _{GA}	GATE to ANODE	15		V
C _{ANODE}	ANODE Input Capacitor	22		nF
C _{CATHODE}	CATHODE Output Capacitor	0.1		μF
C _{VA}	VCAP to ANODE Capacitor	0.1		μF
T _J	Junction Temperature Range	-40	150	°C

Thermal Information

Package Type	θ_{JA}	θ_{JB}	$\theta_{JC, TOP}$	Unit
SOT23-6	153.7	47.8	81	°C/W

Automotive 65-V Reverse Protection Ideal Diode Controller
Electrical Characteristics

All test conditions: $T_A = -40^{\circ}\text{C}$ to $+125^{\circ}\text{C}$; typical values at $T_A = 25^{\circ}\text{C}$, $V_{\text{ANODE}} = 12\text{ V}$, $C_{\text{VCAP}} = 0.1\ \mu\text{F}$, $V_{\text{EN}} = 3.3\text{ V}$, over operating free-air temperature range (unless otherwise noted)

Parameter	Conditions	Min	Typ	Max	Unit	
Supply Voltage and Current						
V_{ANODE}	Operating Input Voltage	4		60	V	
$V_{\text{ANODE_UV}}$	ANODE Under-Voltage Lockout Threshold	V_{ANODE} rising		3.9	V	
		V_{ANODE} falling	2.2	2.4	3.0	V
I_{LO}	ANODE Under-Voltage Lockout Hysteresis	0.44		1.08	V	
I_{SD}	Shutdown Current	$V_{\text{EN}} = 0\text{ V}$, $T_A = -40^{\circ}\text{C}$ to $+85^{\circ}\text{C}$		0.4	1.9	μA
		$V_{\text{EN}} = 0\text{ V}$, $T_A = -40^{\circ}\text{C}$ to $+125^{\circ}\text{C}$			6	μA
I_{Q}	Quiescent Current		60	100	μA	
Enable Input						
$V_{\text{IL_EN}}$	Enable Input Low Threshold	0.5	0.8	1.1	V	
$V_{\text{IH_EN}}$	Enable Input High Threshold	1.1	1.6	2.2	V	
$V_{\text{HYST_EN}}$	Enable Hysteresis	0.52		1.35	V	
I_{EN}	Enable Pin Sink Current	$V_{\text{EN}} = 12\text{ V}$		1	2	μA
ANODE (A) to CATHODE (K) Voltage						
$V_{\text{AK_REG}}$	Regulated Forward Threshold	13	20	29	mV	
V_{AK}	V_{AK} Threshold for Full Conduction Mode ⁽¹⁾	34	50	57	mV	
$V_{\text{AK_REV}}$	V_{AK} Threshold for Reverse Current Blocking	-17	-11	-2	mV	
GM	Regulation Error AMP Transconductance ⁽¹⁾	1200	1800	3100	$\mu\text{A/V}$	
Gate Drive						
I_{GATE}	Peak Source Current	$V_{\text{ANODE}} - V_{\text{CATHODE}} = 100\text{ mV}$, $V_{\text{GATE}} - V_{\text{ANODE}} = 5\text{ V}$	3	13		mA
	Peak Sink Current ⁽¹⁾	$V_{\text{ANODE}} - V_{\text{CATHODE}} = -20\text{ mV}$, $V_{\text{GATE}} - V_{\text{ANODE}} = 5\text{ V}$		2370		mA
	Regulation Max Sink Current	$V_{\text{ANODE}} - V_{\text{CATHODE}} = 0\text{ V}$, $V_{\text{GATE}} - V_{\text{ANODE}} = 5\text{ V}$	6	26		μA
R_{DIS}	Discharge Switch Resistance	$V_{\text{ANODE}} - V_{\text{CATHODE}} = -20\text{ mV}$, $V_{\text{GATE}} - V_{\text{ANODE}} = 100\text{ mV}$	0.4		2	Ω
Charge Pump						
I_{VCAP}	Charge Pump Source Current (Charge Pump On)	$V_{\text{VCAP}} - V_{\text{ANODE}} = 7\text{ V}$	162	285	600	μA

Automotive 65-V Reverse Protection Ideal Diode Controller

Parameter		Conditions	Min	Typ	Max	Unit
	Charge Pump Sink Current (Charge Pump Off)	$V_{VCAP} - V_{ANODE} = 14\text{ V}$		4	10	μA
$V_{VCAP} - V_{ANODE}$	Charge Pump Voltage at $V_{ANODE} = 3.2\text{ V}$	$I_{VCAP} \leq 30\ \mu\text{A}$	8			V
	Charge Pump Turn ON Voltage		9.8	11.1	12.5	V
	Charge Pump Turn OFF Voltage		10.7	12.1	13.5	V
	Charge Pump Enable Comparator Hysteresis		0.6	0.97	1.2	V
V_{VCAP_UVLO}	$V_{VCAP} - V_{ANODE}$ UV Release at Rising Edge	$V_{ANODE} - V_{CATHODE} = 100\text{ mV}$	5.4	6.2	7	V
	$V_{VCAP} - V_{ANODE}$ UV Threshold at Falling Edge	$V_{ANODE} - V_{CATHODE} = 100\text{ mV}$	4.4	5.2	5.9	V
CATHODE						
$I_{CATHODE}$	CATHODE Sink Current	$V_{ANODE} = 12\text{ V}, V_{ANODE} - V_{CATHODE} = -100\text{ mV}$		1.7	2.5	μA
		$V_{ANODE} - V_{CATHODE} = 100\text{ mV}$		0.57	1.5	μA
		$V_{ANODE} = -12\text{ V}, V_{CATHODE} = 12\text{ V}$			1	μA
Switching Characteristics						
t_{EN_DLY}	Delay Time from Enable (LOW to HIGH) to Gate Turn On	$V_{VCAP} > V_{VCAP_UVLO}$		75	110	μs
t_{REV_DLY}	Delay Time from Reverse Voltage Detection to Gate Turn OFF	$V_{ANODE} - V_{CATHODE} = 100\text{ mV}$ to -100 mV		0.39	0.70	μs
t_{FAW_DLY}	Delay Time from Forward Voltage Detection to Gate Turn ON	$V_{ANODE} - V_{CATHODE} = -100\text{ mV}$ to 700 mV		1.5	2.5	μs

(1) Not subject to production test, specified by design.

Automotive 65-V Reverse Protection Ideal Diode Controller

Typical Performance Characteristics

All test conditions: $T_A = 25^\circ\text{C}$, $V_{\text{ANODE}} = 12\text{ V}$, $C_{\text{VCAP}} = 0.1\ \mu\text{F}$, $V_{\text{EN}} = 3.3\text{ V}$, over operating free-air temperature range (unless otherwise noted).

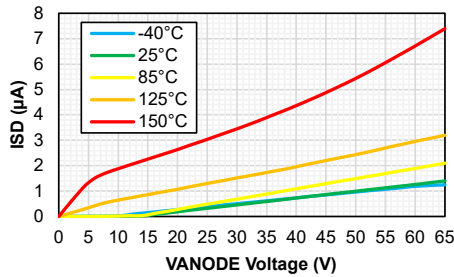

Figure 1. Shutdown Supply Current vs Supply Voltage

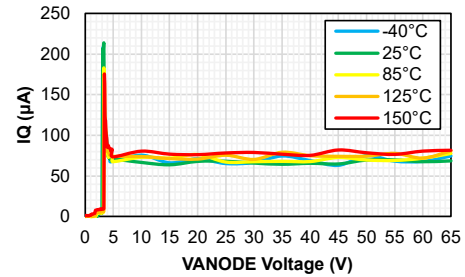

Figure 2. Operating Quiescent Current vs Supply Voltage

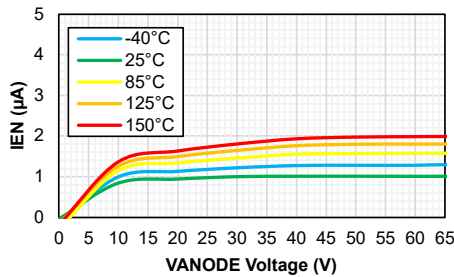

Figure 3. Enable Sink Current vs Supply Voltage

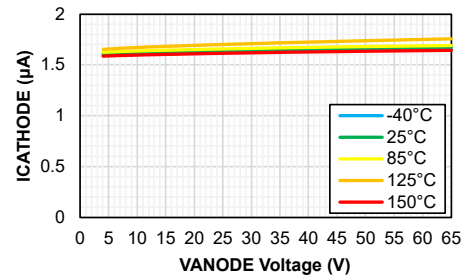

Figure 4. CATHODE Sink Current vs Supply Voltage

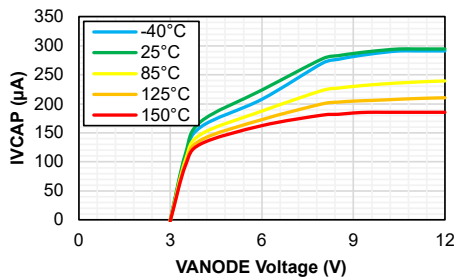

Figure 5. Charge Pump Current vs Supply Voltage at $V_{\text{VCAP}} = 6\text{ V}$

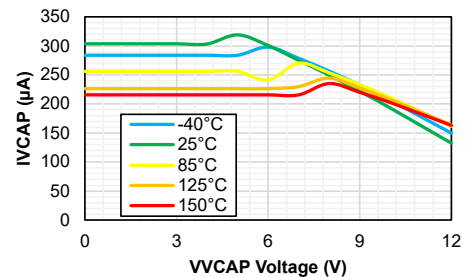

Figure 6. Charge Pump V-I Characteristics at $V_{\text{ANODE}} = 12\text{ V}$

Automotive 65-V Reverse Protection Ideal Diode Controller

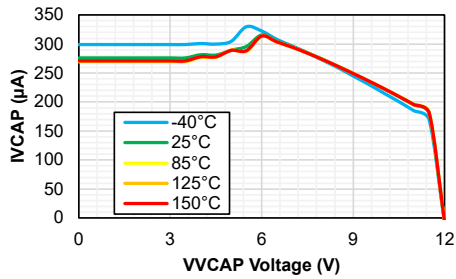

Figure 7. Charge Pump V-I Characteristics at $V_{ANODE} = 65$ V

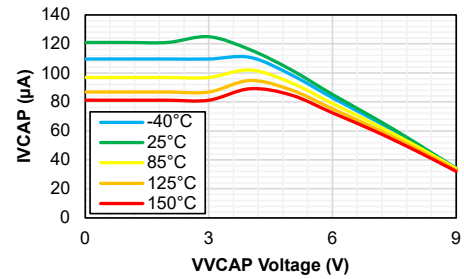

Figure 8. Charge Pump V-I Characteristics at $V_{ANODE} = 3.2$ V

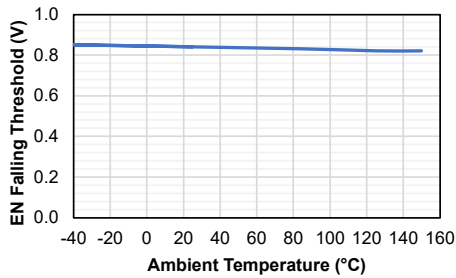

Figure 9. Enable Falling Threshold vs Temperature

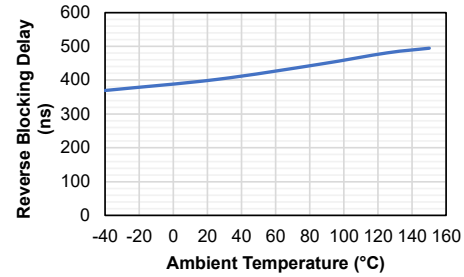

Figure 10. Reverse Current Blocking Delay vs Temperature

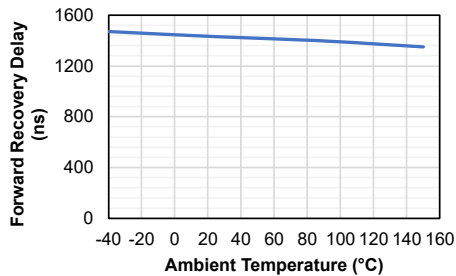

Figure 11. Forward Recovery Delay vs Temperature

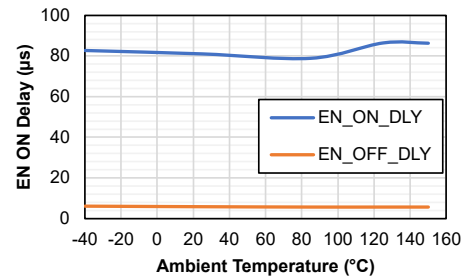

Figure 12. Enable to Gate Delay vs Temperature

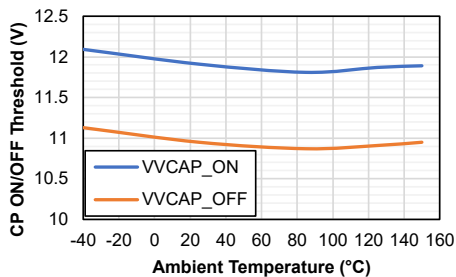

Figure 13. Charge Pump ON/OFF Threshold vs Temperature

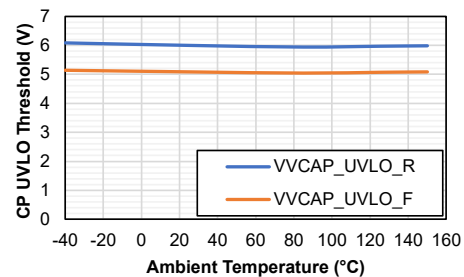
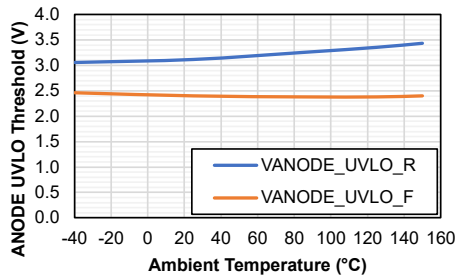
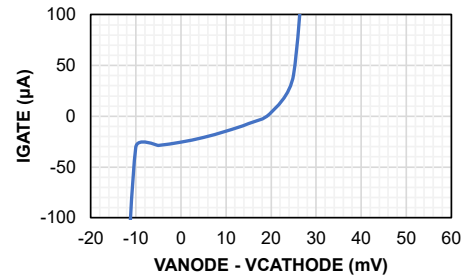
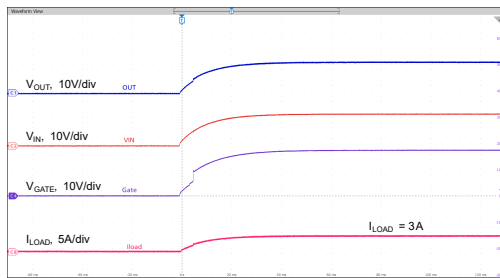
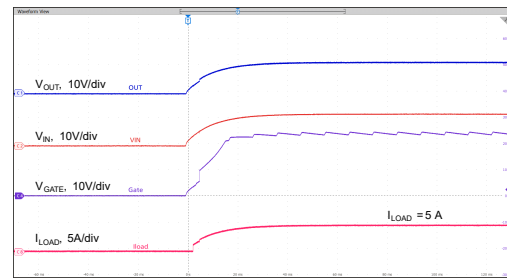
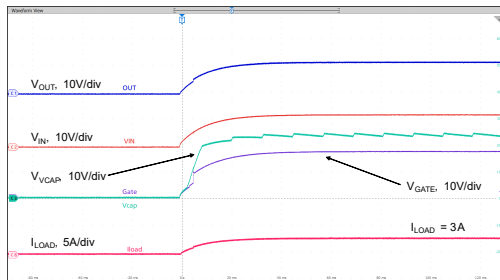
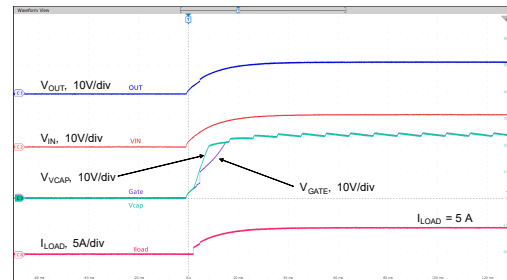
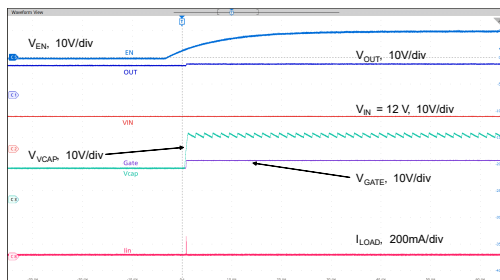
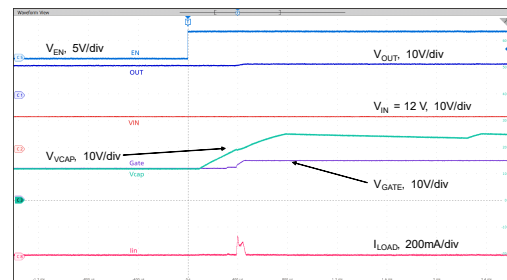

Figure 14. Charge Pump UVLO Threshold vs Temperature

Automotive 65-V Reverse Protection Ideal Diode Controller

Figure 15. ANODE UVLO Threshold vs Temperature

Figure 16. Gate Current vs Forward Voltage Drop

Figure 17. Startup with 3-A Load

Figure 18. Startup with 5-A Load

Figure 19. VCAP During Startup with 3-A Load

Figure 20. VCAP During Startup with 5-A Load

Figure 21. Enable Threshold

Figure 22. Enable Turn-On Delay

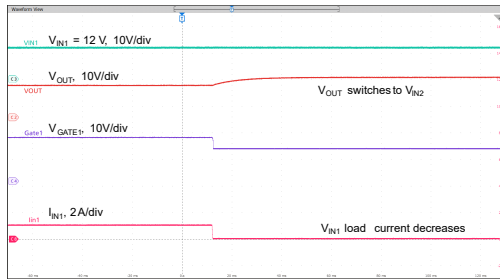

Figure 23. ORing: V_{IN1} Switches to V_{IN2}

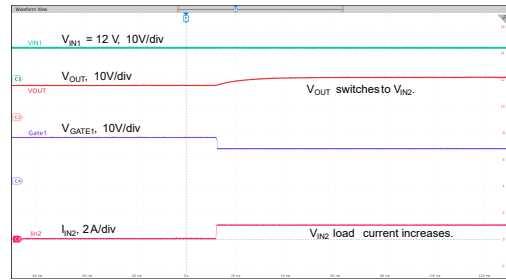

Figure 24. ORing: V_{IN1} Switches to V_{IN2}

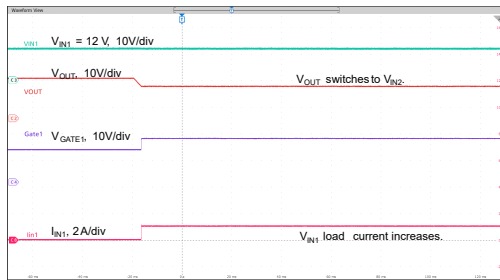

Figure 25. ORing: V_{IN2} Switches to V_{IN1}

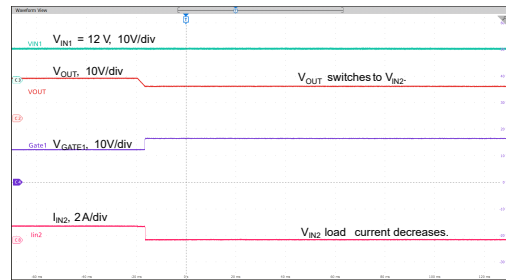

Figure 26. ORing: V_{IN2} Switches to V_{IN1}

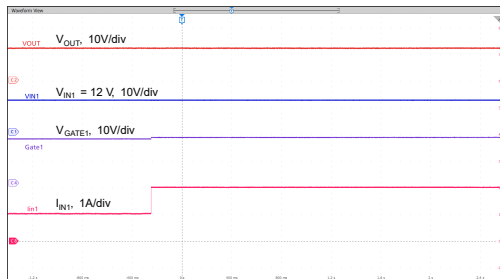

Figure 27. ORing: V_{IN2} Fails and Switches to V_{IN1}

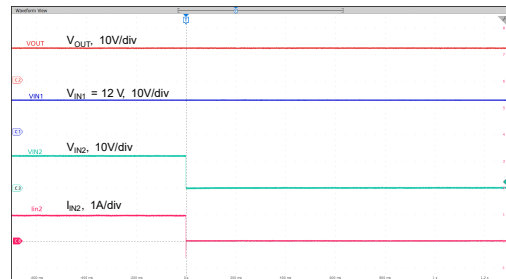

Figure 28. ORing: V_{IN2} Fails and Switches to V_{IN1}

Detailed Description

Overview

The TPS65R01Q is an ideal diode controller that operates with an external N-channel MOSFET for reverse protection in automotive. The forward voltage drop is controlled at as low as 20 mV, which could significantly reduce power loss compared to an ordinary Schottky Diode.

The TPS65R01Q supports a wide operating voltage range from 3.2 V to 60 V, with an absolute maximum rating of 65 V. The support for a 3.2-V input voltage is particularly suitable to meet the severe cold crank requirement in automotive systems. Moreover, this device can withstand a -60 V reverse voltage, with an absolute maximum rating of -65 V.

The TPS65R01Q integrates a charge pump to drive the external N-channel MOSFET. The device provides a precise gate control to regulate the voltage drop between the source and drain at 20 mV. When it detects a reverse voltage of -11 mV from ANODE (A) to CATHODE (K), the TPS65R01Q will turn off the external MOSFET within 700 ns maximum to ensure no reverse current flows.

Functional Block Diagram

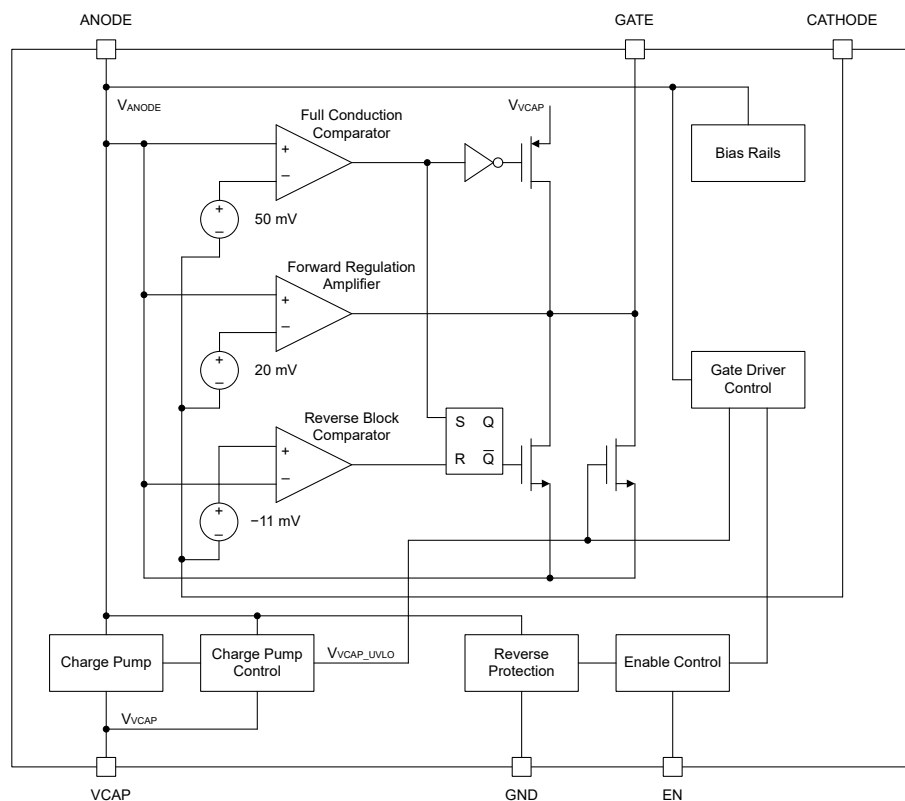

Figure 29. Functional Block Diagram

Feature Description

Input Power Supply Voltage (ANODE)

The TPS65R01Q uses the ANODE pin to power up the internal circuitry with a supply voltage ranging from 3.2 V to 60 V. The maximum voltage range from ANODE to GND is between 65 V to -65 V, allowing the device to withstand negative voltage transients.

When the ANODE pin voltage is lower than the V_{ANODE_UVLO} falling threshold, the TPS65R01Q enters shutdown mode with a low shutdown current. When the ANODE pin voltage is greater than the V_{ANODE_UVLO} rising threshold and EN is high, the TPS65R01Q enters conduction mode with low quiescent current.

Enable (EN)

The TPS65R01Q uses the EN pin to control the gate driver, enabling it to turn on or off. The maximum voltage from EN to GND is 65 V, allowing the EN pin to be connected directly to the ANODE pin if the enable functionality is not required.

When the EN pin voltage is lower than V_{IL_EN} , the device enters shutdown mode, disabling the gate driver and the charge pump. When the EN pin voltage exceeds V_{IH_EN} , the device enters conduction mode, enabling the gate driver and the charge pump. By default, the EN pin is pulled low when floating.

Charge Pump (VCAP)

The TPS65R01Q integrates a charge pump for the external N-channel MOSFET gate driver power supply by connecting a capacitor between the VCAP pin and the ANODE pin. When V_{EN} is greater than V_{IH_EN} , the charge pump typically sources a 285- μ A current to turn on the external MOSFET. When V_{EN} is lower than V_{IL_EN} , the charge pump remains disabled.

To ensure the external MOSFET is well operated, the VCAP to ANODE voltage must exceed V_{VCAP_UVLO} before the internal gate driver is enabled. When the VCAP to ANODE voltage ramps above 12.1 V, the charge pump is disabled and starts discharging; when the VCAP to ANODE voltage falls below 11.1 V, the charge pump is re-enabled and starts charging again. The charge pump continues to operate with the VCAP to ANODE voltage charging and discharging between 11.1 V and 12.1 V.

Gate Driver (GATE) and Conduction Mode

The TPS65R01Q uses the gate driver to control the conduction mode of the external N-channel MOSFET. The gate driver function is enabled when $V_{ANODE} \geq V_{ANODE_UVLO}$, $V_{EN} \geq V_{IH_EN}$, and $V_{VCAP} - V_{ANODE} \geq V_{VCAP_UVLO}$.

While the gate driver is active, there are three different condition modes based on the ANODE to CATHODE voltage: forward regulation mode, full conduction mode, and reverse current protection mode.

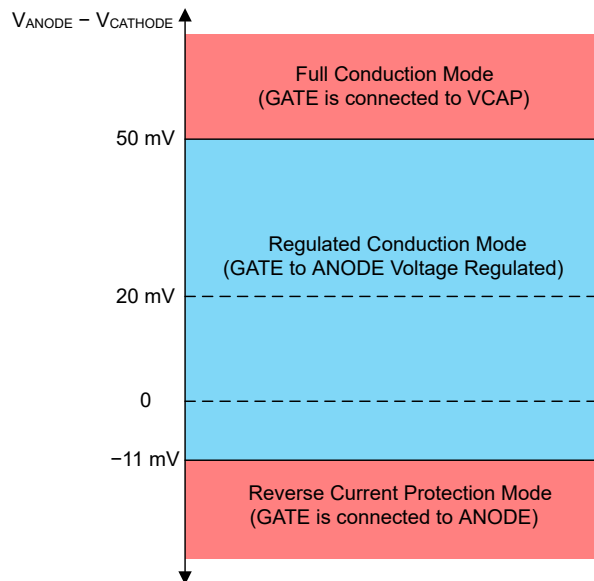
Automotive 65-V Reverse Protection Ideal Diode Controller

Figure 30. Conduction Mode
Forward Regulation Mode

When the gate driver is enabled, and the current flows through the external MOSFET keeping the ANODE to CATHODE voltage within the range of -11 mV to 50 mV typically, the TPS65R01Q operates in the forward regulation mode. In this mode, the TPS65R01Q regulates the ANODE to CATHODE voltage to 20 mV by fine-tuning the GATE to ANODE voltage. This closed-loop regulatory approach allows for a smooth deactivation of the MOSFET under light load conditions and ensures that there is no reverse DC current flow.

Full Conduction Mode

When the gate driver is enabled, and a large current flows through the external MOSFET resulting in the ANODE to CATHODE voltage greater than 50 mV typically, the TPS65R01Q operates in the full conduction mode. In this mode, the GATE pin is connected to the VCAP pin internally and the GATE to ANODE voltage is close to the VCAP to ANODE voltage. With the VCAP and GATE connected internally, the turn-on resistance of the external MOSFET is minimized, and the power dissipation of the external MOSFET is reduced under large forward current conditions.

Reverse Current Protection Mode

When the gate driver is enabled, and the current flows through the external MOSFET resulting in a reverse voltage of less than -11 mV typically from CATHODE to ANODE, the TPS65R01Q operates in reverse current protection mode. When the TPS65R01Q enters reverse protection mode, the GATE pin is discharged to the ANODE pin internally with a current of 2.37 A typically. With the GATE pin discharged, the external MOSFET is disabled, preventing any reverse current flow.

Application and Implementation

Note

Information in the following application sections is not part of the 3PEAK's component specification and 3PEAK does not warrant its accuracy or completeness. 3PEAK's customers are responsible for determining suitability of components for their purposes. Customers should validate and test their design implementation to confirm system functionality.

Application Information

The TPS65R01Q is an ideal diode controller operating with an external N-channel MOSFET for reverse protection in various automotive applications. The following [Typical Application](#) section shows a typical usage of the TPS65R01Q.

Typical Application

Reverse-Protection Application

[Figure 31](#) shows the typical protection application schematic of the TPS65R01Q.

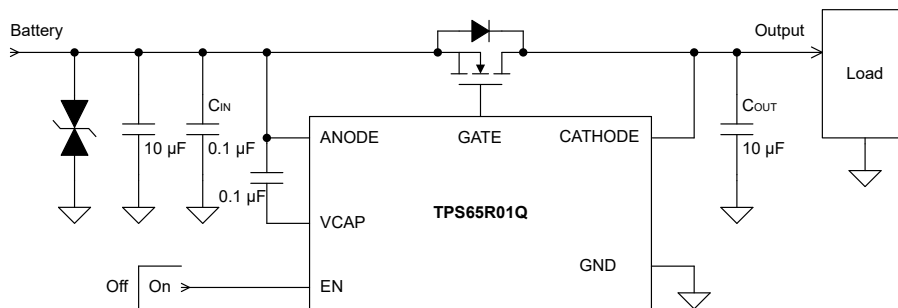

Figure 31. Reverse Protection Application Circuit

Design Example of Reverse Protection Application

Before beginning a new design, the following two points need to be considered first:

1. Supply voltage range, especially the cold crank and load dump in the automotive environment
2. Load current range during normal operation and the maximum load current.

[Table 2](#) shows a design example with system parameters listed.

Table 2. Design Example Parameters

Design Parameter	Example value
Supply Voltage	Automotive 12-V battery, 9-V to 16-V nominal with 3.2-V cold crank and 35-V load dump
Output Voltage	Follow Supply Voltage
Output Current	3 A nominal, 5 A maximum
Output Capacitance	1-µF minimum, 47-µF typical hold-up capacitance
Automotive EMC Compliance	ISO 7637-2 and ISO 16750-2

Automotive 65-V Reverse Protection Ideal Diode Controller

After the design parameters are confirmed, the next considerations should be the MOSFET, input and output capacitors, and the charge pump-up capacitor.

1. External N-channel MOSFET.

Key electrical specifications to consider for a MOSFET include the maximum continuous drain current I_D , the maximum drain-to-source voltage V_{DS_MAX} , the maximum gate-to-source voltage V_{GS_MAX} , the maximum source current through the body diode, and the drain-to-source on-state resistance R_{DS_ON} .

The maximum continuous drain current I_D should be greater than the maximum load current required. The maximum drain-to-source voltage V_{DS_MAX} must be sufficient to handle the peak differential voltage encountered in the application. The maximum gate-to-source voltage V_{GS_MAX} should be higher than the maximum charge pump voltage, otherwise a Zener diode is required to clamp the V_{GS} voltage. The maximum source current rating of the body diode must be greater than the startup inrush current expected in the application.

Using a MOSFET with R_{DS_ON} as low as possible is a good practice to reduce the conduction power loss. However, a very low R_{DS_ON} makes it difficult to implement reverse current detection. It is recommended to operate the MOSFET in regulated conduction mode during nominal load conditions and it is suggested to choose R_{DS_ON} between $20 \text{ mV}/I_{OUT_NORMAL}$ and $50 \text{ mV}/I_{OUT_NORMAL}$.

The thermal resistance of the MOSFET must be taken into account to ensure the maximum junction temperature remains within the safe area under the maximum power dissipation condition.

2. It is recommended to add a minimum 22 nF input capacitor at the ANODE pin and a minimum 100 nF output capacitor at the CATHODE pin. Both the input capacitor and the output capacitor should be placed as close to the device pins as possible.
3. It is required to add a minimum 100 nF capacitor from the VCAP pin to the ANODE pin. It is a good practice to add a VCAP capacitor with value of $10 \times C_{ISS_MOSFET}$.

Figure 17 to Figure 22 show the typical performance characteristics of the reverse protection application.

Redundant Power Supplies Application

In a redundant power architecture, usually two or more power supplies are connecting together to drive the same load. To against power fault conditions, Schottky diodes are commonly used to prevent reverse current flowing from higher-voltage power to lower-voltage power. However, the forward voltage of each Schottky diode would cause much more additional power dissipation compared with an ideal diode solution.

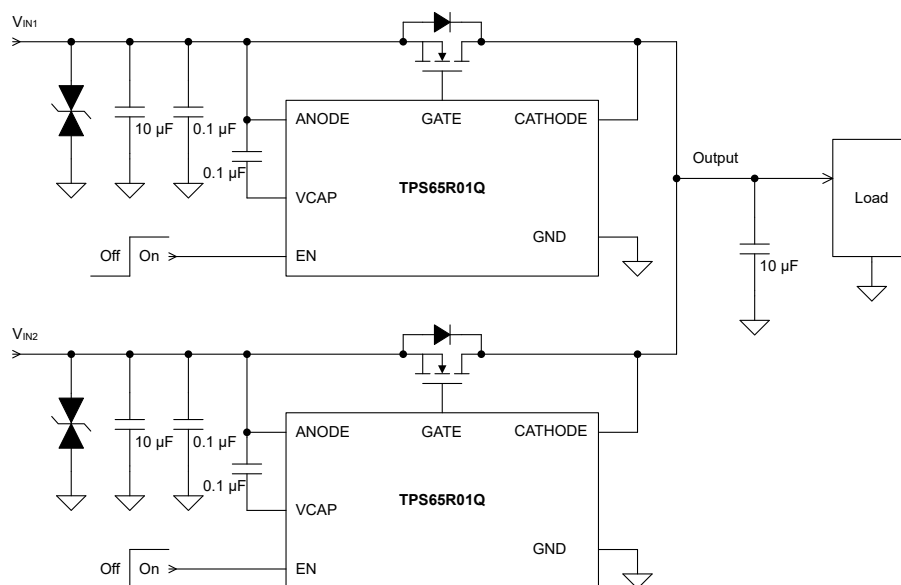

Figure 32. Redundant Power Supplies Application

Automotive 65-V Reverse Protection Ideal Diode Controller

Figure 32 shows the redundant power supplies application schematic with the TPS65R01Q devices. The TPS65R01Q continuously monitors the voltage difference between the ANODE pin and the CATHODE pin. During forward operation mode, the voltage drop remains at 20 mV typically. When reverse voltage below -11 mV is detected, the TPS65R01Q turns off the gate of the MOSFET quickly and blocks reverse current in 390 ns typically.

Figure 23 to Figure 28 show the typical performance characteristics of the redundant power supplies application.

Tape and Reel Information

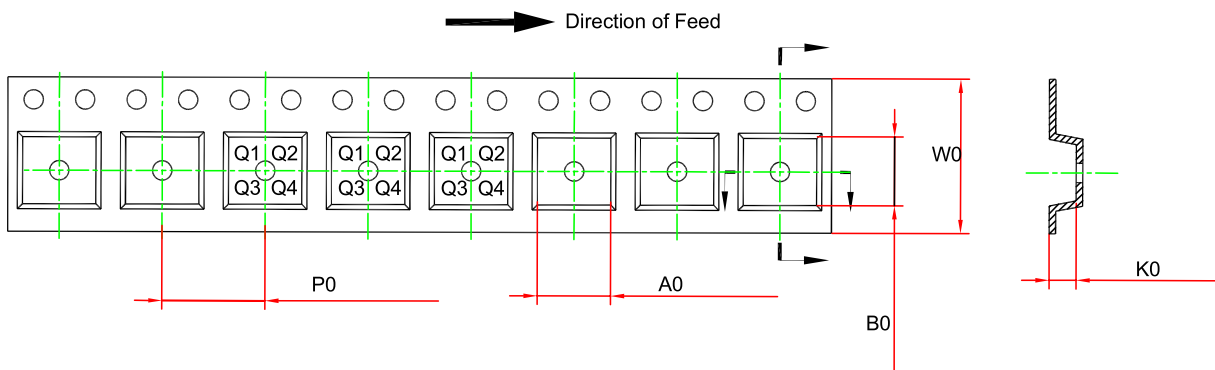
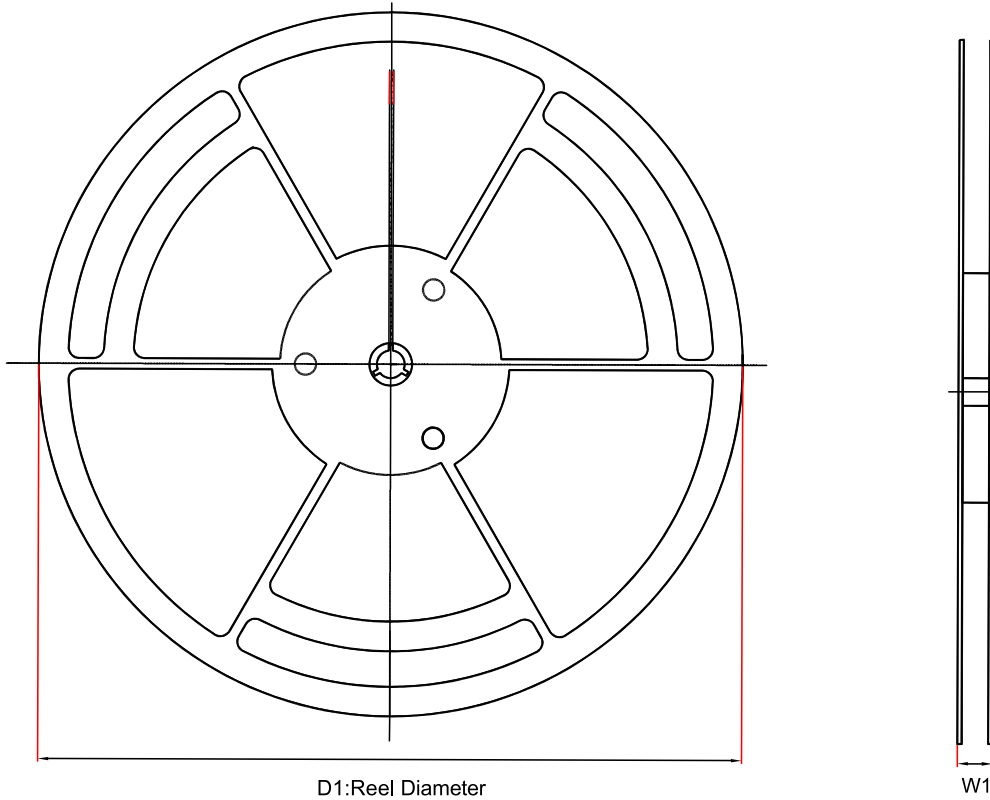

Order Number	Package	D1 (mm)	W1 (mm)	A0 (mm)	B0 (mm)	K0 (mm)	P0 (mm)	W0 (mm)	Pin1 Quadrant
TPS65R01Q-S6TR-S	SOT23-6	180	12	3.3	3.2	1.4	4	8	Q3

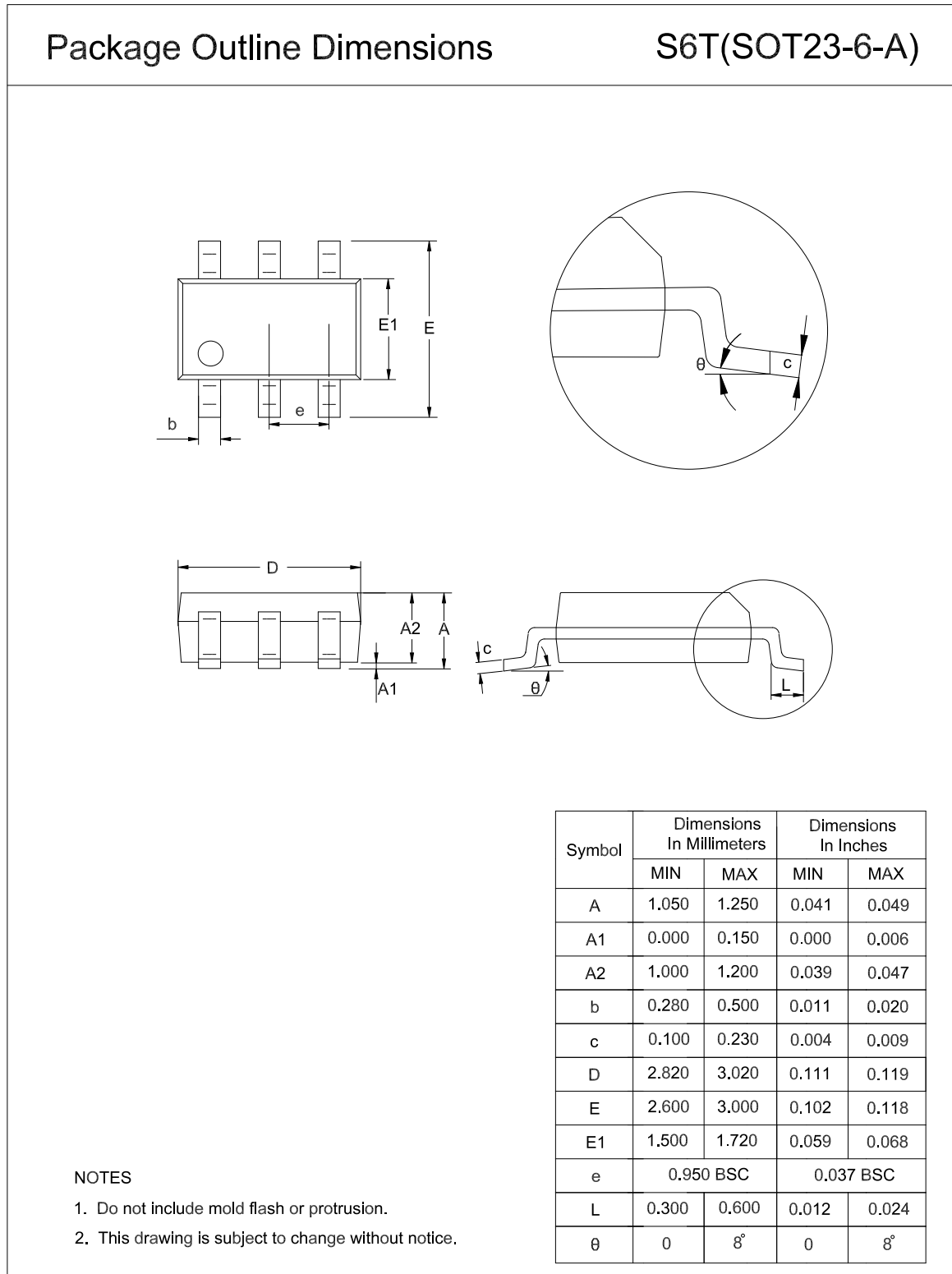
Package Outline Dimensions
SOT23-6

Order Information

Order Number	Operating Temperature Range	Package	Marking Information	MSL	Transport Media, Quantity	Eco Plan
TPS65R01Q-S6TR-S	-40 to 125°C	SOT23-6	65R	MSL2	Tape and Reel, 3000	Green

Green: 3PEAK defines "Green" to mean RoHS compatible and free of halogen substances.

IMPORTANT NOTICE AND DISCLAIMER

Copyright© 3PEAK 2012-2024. All rights reserved.

Trademarks. Any of the 思瑞浦 or 3PEAK trade names, trademarks, graphic marks, and domain names contained in this document /material are the property of 3PEAK. You may NOT reproduce, modify, publish, transmit or distribute any Trademark without the prior written consent of 3PEAK.

Performance Information. Performance tests or performance range contained in this document/material are either results of design simulation or actual tests conducted under designated testing environment. Any variation in testing environment or simulation environment, including but not limited to testing method, testing process or testing temperature, may affect actual performance of the product.

Disclaimer. 3PEAK provides technical and reliability data (including data sheets), design resources (including reference designs), application or other design recommendations, networking tools, security information and other resources "As Is". 3PEAK makes no warranty as to the absence of defects, and makes no warranties of any kind, express or implied, including without limitation, implied warranties as to merchantability, fitness for a particular purpose or non-infringement of any third-party's intellectual property rights. Unless otherwise specified in writing, products supplied by 3PEAK are not designed to be used in any life-threatening scenarios, including critical medical applications, automotive safety-critical systems, aviation, aerospace, or any situations where failure could result in bodily harm, loss of life, or significant property damage. 3PEAK disclaims all liability for any such unauthorized use.

This page intentionally left blank