

**24-V Input, 180-mA Output
High Voltage and Low Quiescent Current LDO****Features**

- Wide Input Voltage Range: 3.6 V to 24 V
- $\pm 1\%$ Output Accuracy Under Room Temperature
 - Fixed Output: 2.8 V, 3 V, 3.3 V, and 5 V
 - Adjustable Output: 1.2 V to 15 V
- Ultra-Low Quiescent Current: 2 μA
- Maximum Output Current: 180 mA
- Low Dropout Voltage: 200 mV at 50 mA
- High PSRR: 73 dB at 100 Hz
- Current Limit and Thermal Protection
- Stable with 2.2 μF to 22 μF Low ESR Ceramic Capacitor
- Soft Start Limits Input Current Surge During Enable
- Thermal Shutdown Protection
- Junction Temperature Range: -40°C to $+125^{\circ}\text{C}$
- Packages: SOT89-3, SOT23-5, SOT23-3

Applications

- Handheld Devices with Battery Power Supply
- POS and Power Tools
- Meters and Smoke Detector
- Industrial control
- Wireless and IoT modules

Description

The TPL810 series products are high-performance and low dropout linear regulators. The TPL810 series products support a maximum 24 V input voltage and 180 mA output current with low quiescent current and high PSRR. The TPL810 series products are stable with a 2.2 μF to 22 μF output capacitor, and a 4.7 μF ceramic capacitor is recommended.

The TPL810 series products have a high PSRR with 73 dB at 100 Hz. This feature makes TPL810 series products very suitable for power-sensitive applications with high noise from the previous stage power supply. 2 μA ultra-low quiescent current makes the TPL810 series products ideal choices for portable devices with battery power supply. Current-limit and thermal overload protection circuits improve the reliability under heavy load conditions.

The TPL810 series products provide fixed output voltage options from 2.8 V to 5 V and adjustable output voltage from 1.2 V to 15 V with $\pm 2\%$ voltage accuracy over operating conditions. The TPL810 series products are guaranteed over the junction temperature range from -40°C to $+125^{\circ}\text{C}$.

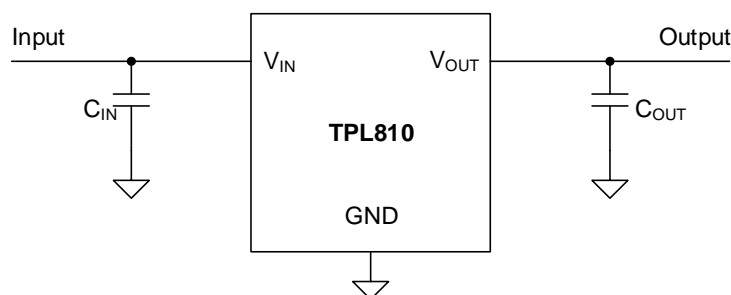
Typical Application Schematic

**24-V Input, 180-mA Output
High Voltage and Low Quiescent Current LDO****Product Family Table**

Order Number	Output Voltage (V)	Package
TPL810ADJ-5TR	Adjustable (1.2 V to 18 V)	SOT23-5
TPL810F28-89TR	Fixed 2.8 V	SOT89-3
TPL810F30-89TR	Fixed 3.0 V	SOT89-3
TPL810F33-89TR	Fixed 3.3 V	SOT89-3
TPL810F50-89TR	Fixed 5.0 V	SOT89-3
TPL810F28-5TR	Fixed 2.8 V	SOT23-5
TPL810F30-5TR	Fixed 3.0 V	SOT23-5
TPL810F33-5TR	Fixed 3.3 V	SOT23-5
TPL810F50-5TR	Fixed 5.0 V	SOT23-5
TPL810U28-5TR	Fixed 2.8 V	SOT23-5 (B)
TPL810U30-5TR	Fixed 3.0 V	SOT23-5 (B)
TPL810U33-5TR	Fixed 3.3 V	SOT23-5 (B)
TPL810U50-5TR	Fixed 5.0 V	SOT23-5 (B)
TPL810F28- 3TR	Fixed 2.8 V	SOT23-3
TPL810F30- 3TR	Fixed 3.0 V	SOT23-3
TPL810F33- 3TR	Fixed 3.3 V	SOT23-3
TPL810F50- 3TR	Fixed 5.0 V	SOT23-3

Table of Contents

Features	1
Applications	1
Description	1
Typical Application Schematic	1
Product Family Table	2
Revision History	4
Pin Configuration and Functions	5
Pin Functions.....	5
Specifications	6
Absolute Maximum Ratings.....	6
ESD, Electrostatic Discharge Protection	6
Recommended Operating Conditions	6
Thermal Information	6
Electrical Characteristics	7
Typical Performance Characteristics.....	8
Detailed Description	10
Overview.....	10
Functional Block Diagram	10
Feature Description	10
Application and Implementation	12
Application Information.....	12
Typical Application	12
Layout	13
Layout Guideline.....	13
Tape and Reel Information	14
Package Outline Dimensions	15
SOT89-3	15
SOT23-5	16
SOT23-3	17
Order Information	18
IMPORTANT NOTICE AND DISCLAIMER	19

**24-V Input, 180-mA Output
High Voltage and Low Quiescent Current LDO****Revision History**

Date	Revision	Notes
2018-09-28	Rev.Pre	Preliminary version
2018-11-27	Rev.A.0	Initial release
2019-05-31	Rev.A.1	Added adjustable output version and fixed 3.7 V output version
2020-04-30	Rev.A.2	Updated thermal information of SOT89-3 package
2021-03-29	Rev.A.3	1. Changed the pin 1 orientation of the SOT23-3 package 2. Added Tape and Reel Information
2021-06-04	Rev.A.4	Corrected the pin name mistake of the SOT23-5 package
2021-08-31	Rev.A.5	Output current changed from 200 mA to 180 mA
2022-03-21	Rev.A.6	1. Added output capacitor upper limit 2. Removed ambient temperature range 3. Removed 1.2 V, 1.8 V, 2.5 V, 3.7 V, and 4.5 V output version 4. Removed SOT89-3 (B) package

24-V Input, 180-mA Output High Voltage and Low Quiescent Current LDO

Pin Configuration and Functions

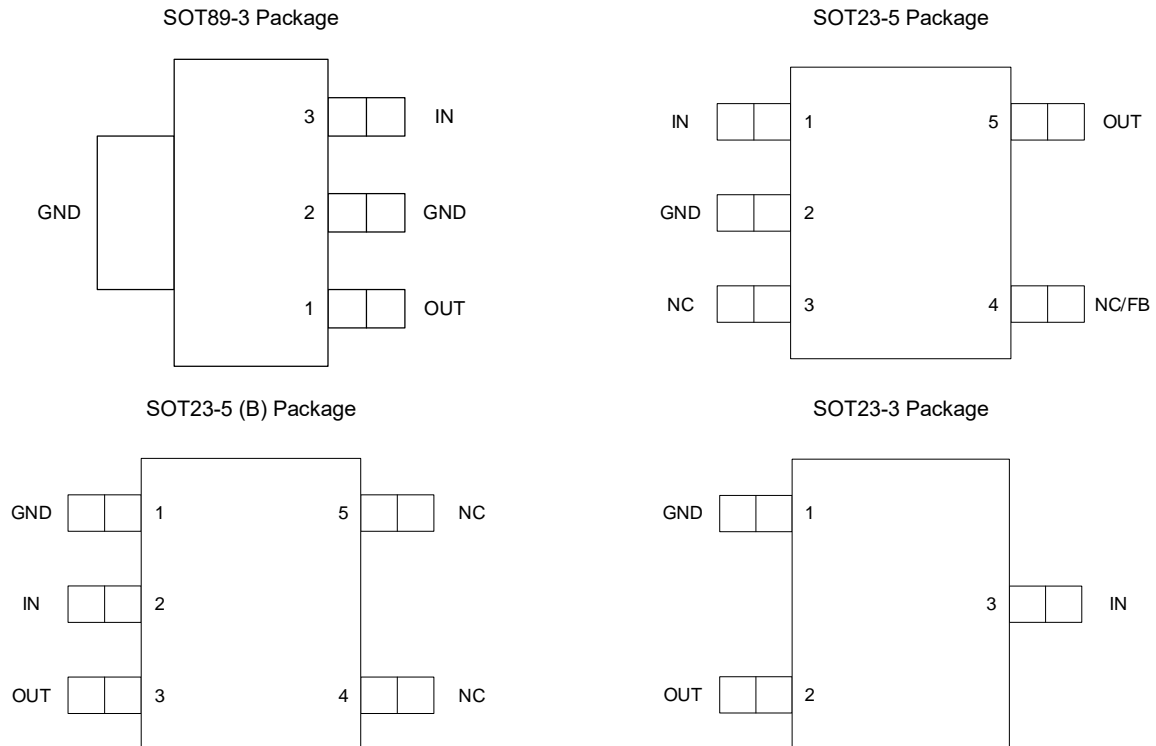

Pin Functions

Pin Name	Pin Number				I/O	Description
	SOT89 -3	SOT23 -5	SOT23 -5 (B)	SOT23 -3		
IN	3	1	2	3	I	Input voltage pin.
NC	–	3, 4	4, 5	–	–	No connection.
FB	–	4	–	–	I	Output feedback pin (Adjustable version only).
OUT	1	5	3	2	O	Regulated output voltage pin.
GND	2	2	1	1	–	Ground reference pin. Connect GND pin to PCB ground plane directly.

(1) Thermal pad must be connected to the PCB ground plane to maximize the thermal performance.

24-V Input, 180-mA Output High Voltage and Low Quiescent Current LDO

Specifications

Absolute Maximum Ratings

Parameter		Min	Max	Unit
V _{IN}	Input Voltage	-0.3	45	V
V _{OUT}	Output Voltage (Fixed version)	-0.3	6	V
V _{OUT}	Output Voltage (Adjustable version)	-0.3	20	V
V _{FB}	Feedback Voltage (Adjustable version)	-0.3	6	V
T _J	Junction Temperature Range	-40	150	°C
T _{STG}	Storage Temperature Range	-65	150	°C
T _L	Lead Temperature (Soldering 10 sec)		260	°C

(1) Stresses beyond those listed under Absolute Maximum Ratings may cause permanent damage to the device. Exposure to any Absolute Maximum Rating condition for extended periods may affect device reliability and lifetime.

(2) All voltage values are with respect to GND.

ESD, Electrostatic Discharge Protection

Symbol	Parameter	Condition	Minimum Level	Unit
HBM	Human Body Model ESD	ANSI/ESDA/JEDEC JS-001 ⁽¹⁾	±2.5	kV
CDM	Charged Device Model ESD	ANSI/ESDA/JEDEC JS-002 ⁽²⁾	±2	kV

(1) JEDEC document JEP155 states that 500-V HBM allows safe manufacturing with a standard ESD control process.

(2) JEDEC document JEP157 states that 250-V CDM allows safe manufacturing with a standard ESD control process.

Recommended Operating Conditions

Parameter		Min	Max	Unit
V _{IN}	Input Voltage	3.6	24	V
V _{OUT}	Output Voltage (Fixed version)	1.2	5	V
V _{OUT}	Output Voltage (Adjustable version)	1.2	15	V
I _{OUT}	Output Current	0	180	mA
T _J	Operating Junction Temperature Range	-40	125	°C
P _D	Power Dissipation (SOT89-3 Package)	0	1000	mW
	Power Dissipation (SOT23-5 Package)	0	300	mW
	Power Dissipation (SOT23-3 Package)	0	300	mW

Thermal Information

Package Type	θ _{JA}	θ _{JC}	Unit
SOT89-3	63.0	9.41	°C/W
SOT23-5	280	62	°C/W
SOT23-3	280	62	°C/W

24-V Input, 180-mA Output High Voltage and Low Quiescent Current LDO

Electrical Characteristics

All test conditions: $V_{IN} = V_{OUT(NOM)} + 1\text{ V}$ or 3.6 V , whichever is greater; $C_{OUT} = 2.2\ \mu\text{F}$, $T_A = +25^\circ\text{C}$, unless otherwise noted.

Symbol	Parameter	Conditions	Min	Typ	Max	Unit
Supply Voltage and Current						
V_{IN}	Input voltage range		3.6		24	V
I_Q	Quiescent current	$I_{OUT} = 0\text{ mA}$		2	5	μA
		$I_{OUT} = 180\text{ mA}$		400		μA
UVLO	V_{IN} under-voltage lock-out	V_{IN} rising		2.9	3.6	V
Regulated Output Voltage and Current						
V_{OUT}	Output voltage accuracy	$T_J = +25^\circ\text{C}$		1%		
		$-40^\circ\text{C} \leq T_J \leq +125^\circ\text{C}$	-2%		2%	
V_{FB}	Feedback voltage accuracy	Adjustable output version		1.2		V
ΔV_{OUT}	Line regulation	$V_{IN} = V_{OUT(NOM)} + 1\text{ V}$ to 24 V , or $V_{IN} \geq 3.6\text{ V}$, $I_{OUT} = 1\text{ mA}$		3		mV
	Load regulation	$I_{OUT} = 1\text{ mA}$ to 180 mA		20		mV
$V_{DO}^{(1)}$	Dropout voltage	$V_{IN} = 0.98 \times V_{OUT(NOM)}$, $I_{OUT} = 50\text{ mA}$		200	600	mV
		$V_{IN} = 0.98 \times V_{OUT(NOM)}$, $I_{OUT} = 180\text{ mA}$		800		mV
I_{OUT}	Output current	V_{OUT} in regulation	0		180	mA
$I_{CL}^{(2)}$	Output current limit	$V_{OUT} = 0.9 \times V_{OUT(NOM)}$	180		800	mA
PSRR	Power supply rejection ratio	$I_{OUT} = 10\text{ mA}$, $f = 100\text{ Hz}$, $C_{OUT} = 4.7\ \mu\text{F}$		75		dB
		$I_{OUT} = 10\text{ mA}$, $f = 1\text{ kHz}$, $C_{OUT} = 4.7\ \mu\text{F}$		65		dB
		$I_{OUT} = 10\text{ mA}$, $f = 10\text{ kHz}$, $C_{OUT} = 4.7\ \mu\text{F}$		65		dB
V_N	Output noise voltage	$I_{OUT} = 10\text{ mA}$, $BW = 10\text{ Hz}$ to 100 kHz		110		μV_{RMS}
		$I_{OUT} = 10\text{ mA}$, $BW = 100\text{ Hz}$ to 100 kHz		70		μV_{RMS}
Temperature Range						
T_{SD}	Thermal shutdown threshold			160		$^\circ\text{C}$
	Hysteresis			40		$^\circ\text{C}$

(1) Dropout voltage is the minimum input to output voltage differential needed to maintain regulation at a specified output current. In dropout, the output voltage will be equal to $V_{IN} - V_{DO}$.

(2) Measured with $V_{IN} = V_{OUT} + 3\text{ V}$ for $V_{OUT(NOM)} \leq 2.5\text{ V}$. Measured with $V_{IN} = V_{OUT} + 2.5\text{ V}$ for $V_{OUT(NOM)} > 2.5\text{ V}$.

24-V Input, 180-mA Output
High Voltage and Low Quiescent Current LDO

Typical Performance Characteristics

All test conditions: $V_{IN} = V_{OUT(NOM)} + 1\text{ V}$ or 3.6 V , whichever is greater; $C_{OUT} = 2.2\text{ }\mu\text{F}$, $T_A = +25^\circ\text{C}$, unless otherwise noted.

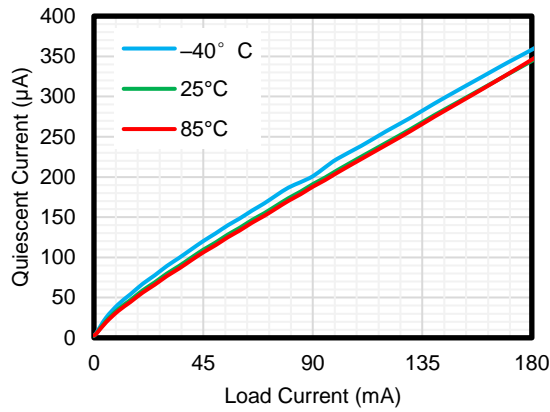

Figure 1. Quiescent Current vs Output Current

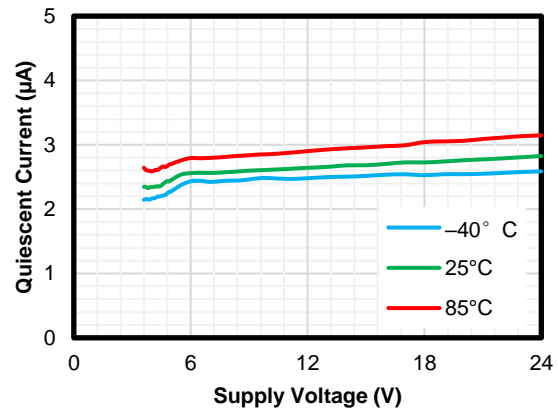

Figure 2. Quiescent Current vs Input Voltage

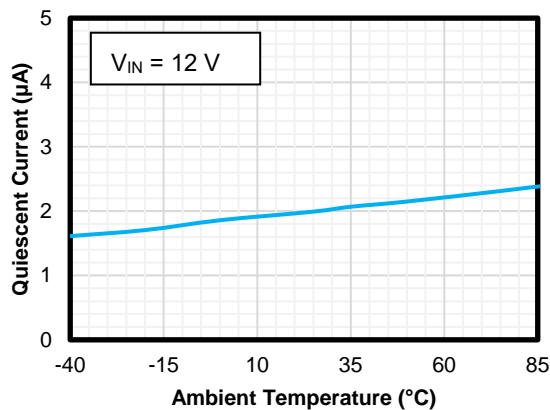

Figure 3. Quiescent Current vs Ambient Temperature

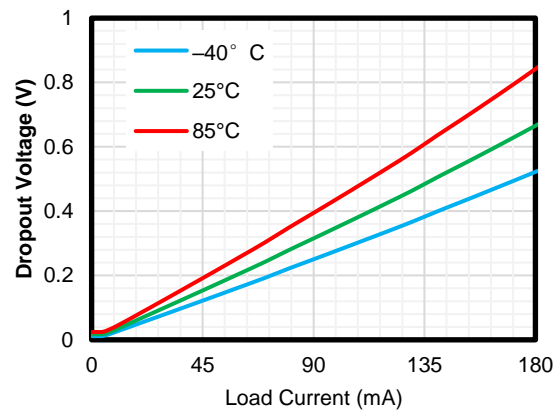

Figure 4. Dropout Voltage vs Output Current

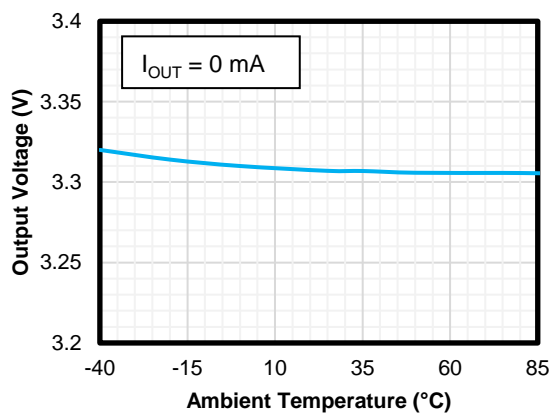

Figure 5. Output Accuracy vs Ambient Temperature

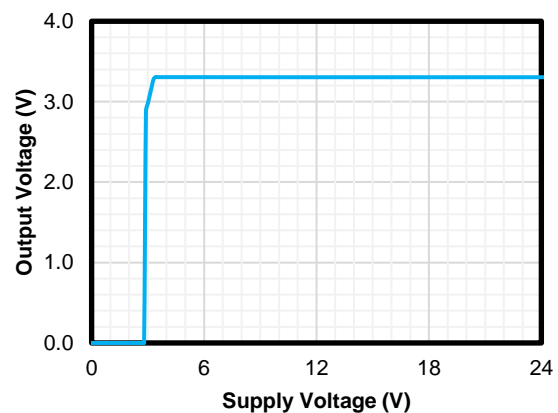

Figure 6. Output Voltage vs Input Voltage

24-V Input, 180-mA Output
High Voltage and Low Quiescent Current LDO

Typical Performance Characteristics (Continued)

All test conditions: $V_{IN} = V_{OUT(NOM)} + 1\text{ V}$ or 3.6 V , whichever is greater; $C_{OUT} = 2.2\text{ }\mu\text{F}$, $T_A = +25^\circ\text{C}$, unless otherwise noted.

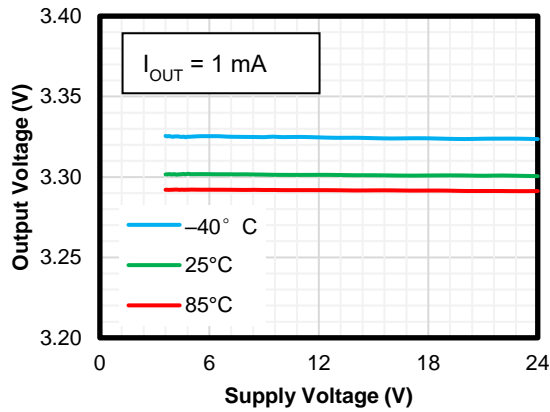

Figure 7. Line Regulation

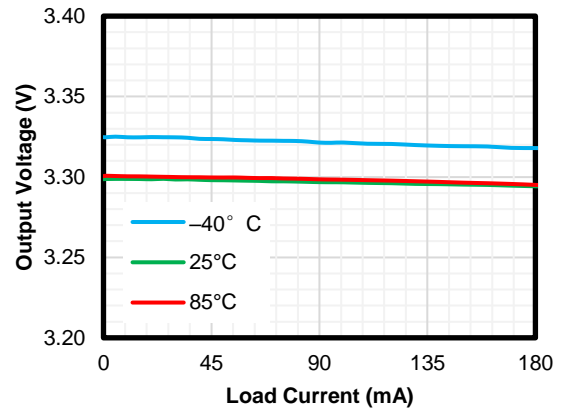

Figure 8. Load Regulation

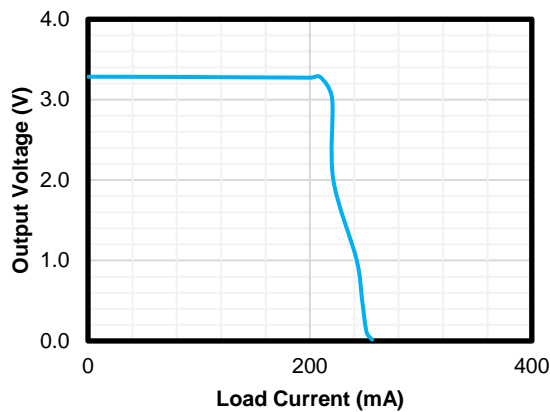

Figure 9. Current Limit

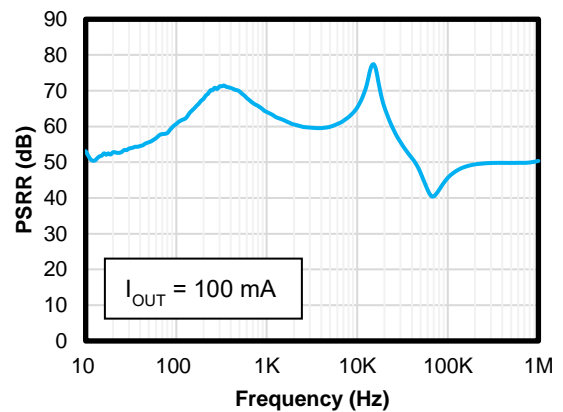

Figure 10. PSRR

**24-V Input, 180-mA Output
High Voltage and Low Quiescent Current LDO**

Detailed Description

Overview

The TPL810 series products are 24-V 180-mA wide input range linear regulators with a very low quiescent current. These voltage regulators operate from 3.6 V to 24 V and consume 2 μ A of quiescent current at no load. The TPL810 series products are available in fixed output voltage versions of 2.8 V, 3 V, 3.3 V, and 5 V, and adjustable output voltage from 1.2 V to 15 V with $\pm 2\%$ output voltage accuracy over operating conditions.

Functional Block Diagram

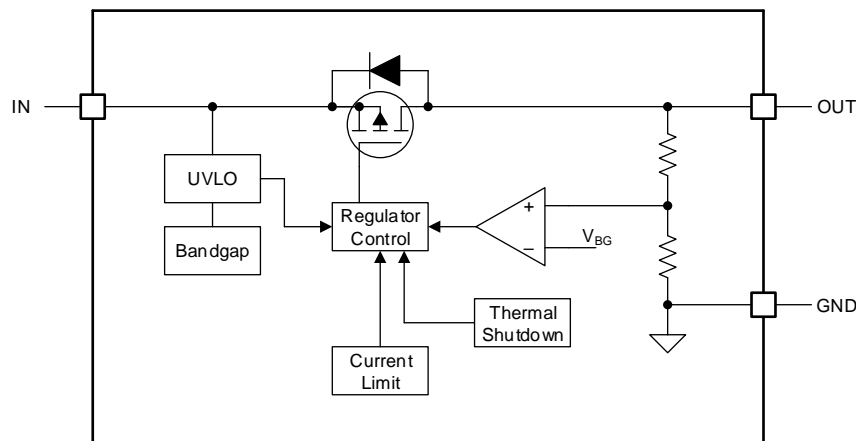

TPL810 Series (Fixed version)

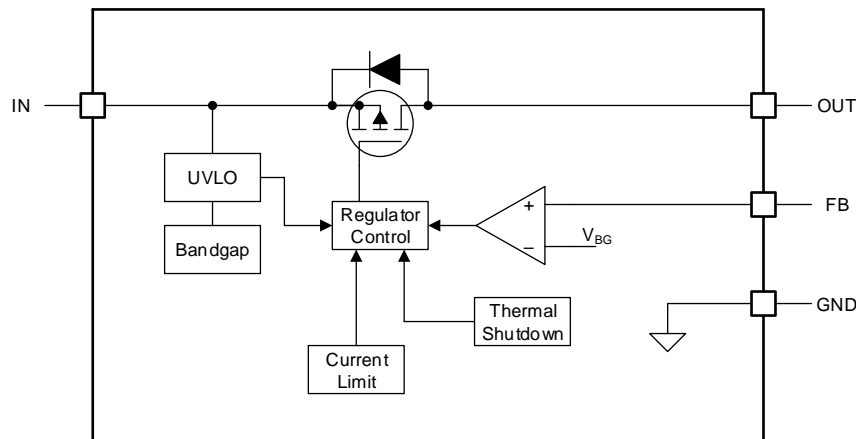

TPL810 Series (Adjustable version)

Feature Description

Under-Voltage Lockout (UVLO)

The TPL810 series uses an under-voltage lock-out circuit (UVLO = 2.9 V) to shut the output down until the internal circuitry operates properly.

24-V Input, 180-mA Output High Voltage and Low Quiescent Current LDO

Regulated Output Voltage

The TPL810 series are available in fixed output voltage versions of 2.8 V, 3 V, 3.3 V, and 5 V. When the input voltage is higher than $V_{OUT(NOM)} + V_{DO}$ or 3.6 V, the output pin is the regulated output based on the selected voltage version. When the input voltage falls below $V_{OUT(NOM)} + V_{DO}$ or 3.6 V, the output pin tracks the input voltage minus the dropout voltage based on the load current. When the input voltage drops below the UVLO threshold, the output keeps shutting off.

Adjustable Output Voltage

The TPL810 series are also available in adjustable output voltage from 1.2 V to 15 V by selecting suitable external resistor dividers.

Use [Equation 1](#) to calculate the output voltage ($V_{FB} = 1.2\text{ V}$). Suggest select resistor value of $(R1 + R2)$ between 10 k Ω and 100 k Ω .

$$V_{OUT} = V_{FB} \times \left(1 + \frac{R1}{R2}\right) \quad (1)$$

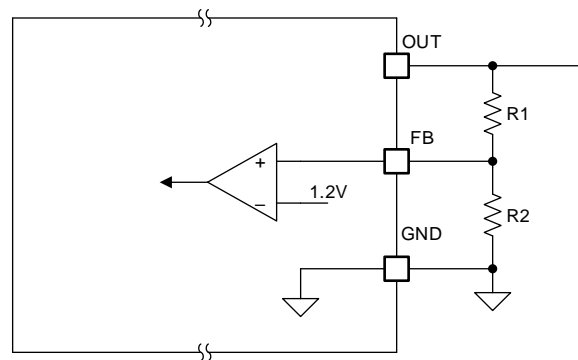

Figure 11. Adjustable Version

Current Limit

The TPL810 series integrates an internal current limit that helps to protect the regulator during fault conditions. The output voltage is not regulated when the device is in the current limit mode and is $V_{OUT} = I_{CL} \times R_{LOAD}$.

Thermal Shutdown

During normal operation, LDO junction temperature should not exceed 125°C. When the junction temperature exceeds the thermal shutdown threshold, the LDO shut down the output immediately. Until when the junction temperature falls below the thermal shutdown threshold minus thermal shutdown hysteresis, the output turns on again.

24-V Input, 180-mA Output High Voltage and Low Quiescent Current LDO

Application and Implementation

NOTE

Information in the following applications sections is not part of the 3PEAK's component specification and 3PEAK does not warrant its accuracy or completeness. 3PEAK's customers are responsible for determining suitability of components for their purposes. Customers should validate and test their design implementation to confirm system functionality.

Application Information

The TPL810 series products are 24-V 180-mA wide input range linear regulators with a very low quiescent current. The following application schematic shows a typical usage of the TPL810 series.

Typical Application

Figure 12 shows the typical application schematic of the TPL810 series.

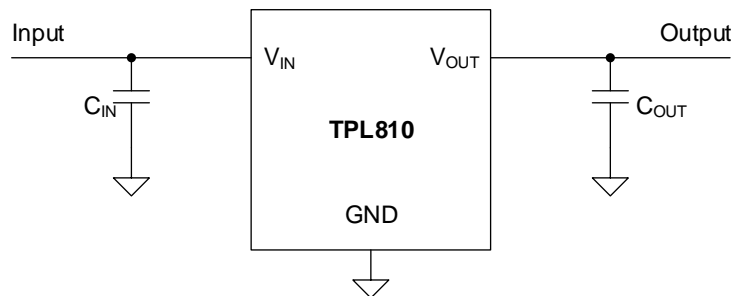

Figure 12. TPL810 Typical Application

Input Capacitor and Output Capacitor

3PEAK recommends adding a 2.2 μF or greater capacitor with a 0.1 μF bypass capacitor in parallel at IN pin to keep the input voltage stable. An aluminum electrolytic capacitor or other capacitors with high capacitance is suggested for the system power with a large voltage spike. The voltage rating of the capacitors must be greater than the maximum input voltage.

To ensure loop stability, the TPL810 series requires an output capacitor with an effective capacitance value of 2.2 μF to 22 μF . 3PEAK recommends selecting an X5R- or X7R-type 4.7 μF ceramic capacitor with low ESR over the temperature range.

Both input capacitors and output capacitors must be placed as close to the device pins as possible.

Power Dissipation

During normal operation, LDO junction temperature should not exceed 125°C. Using the below equations to calculate the power dissipation and estimate the junction temperature.

The power dissipation can be calculated using [Equation 2](#).

$$P_D = (V_{IN} - V_{OUT}) \times I_{OUT} + V_{IN} \times I_{GND} \quad (2)$$

**24-V Input, 180-mA Output
High Voltage and Low Quiescent Current LDO**

The junction temperature can be estimated using [Equation 3](#). θ_{JA} is the junction-to-ambient thermal resistance (See Section [Thermal Information](#)).

$$T_J = T_A + P_D \times \theta_{JA} \quad (3)$$

Layout

Layout Guideline

- Both input capacitors and output capacitors must be placed as close to the device pins as possible.
- It is recommended to bypass the input pin to ground with a 0.1 μF bypass capacitor. The loop area formed by the bypass capacitor connection, the IN pin, and the GND pin of the system must be as small as possible.
- It is recommended to use wide trace lengths or thick copper weight to minimize $I \times R$ drop and heat dissipation.

24-V Input, 180-mA Output High Voltage and Low Quiescent Current LDO

Tape and Reel Information

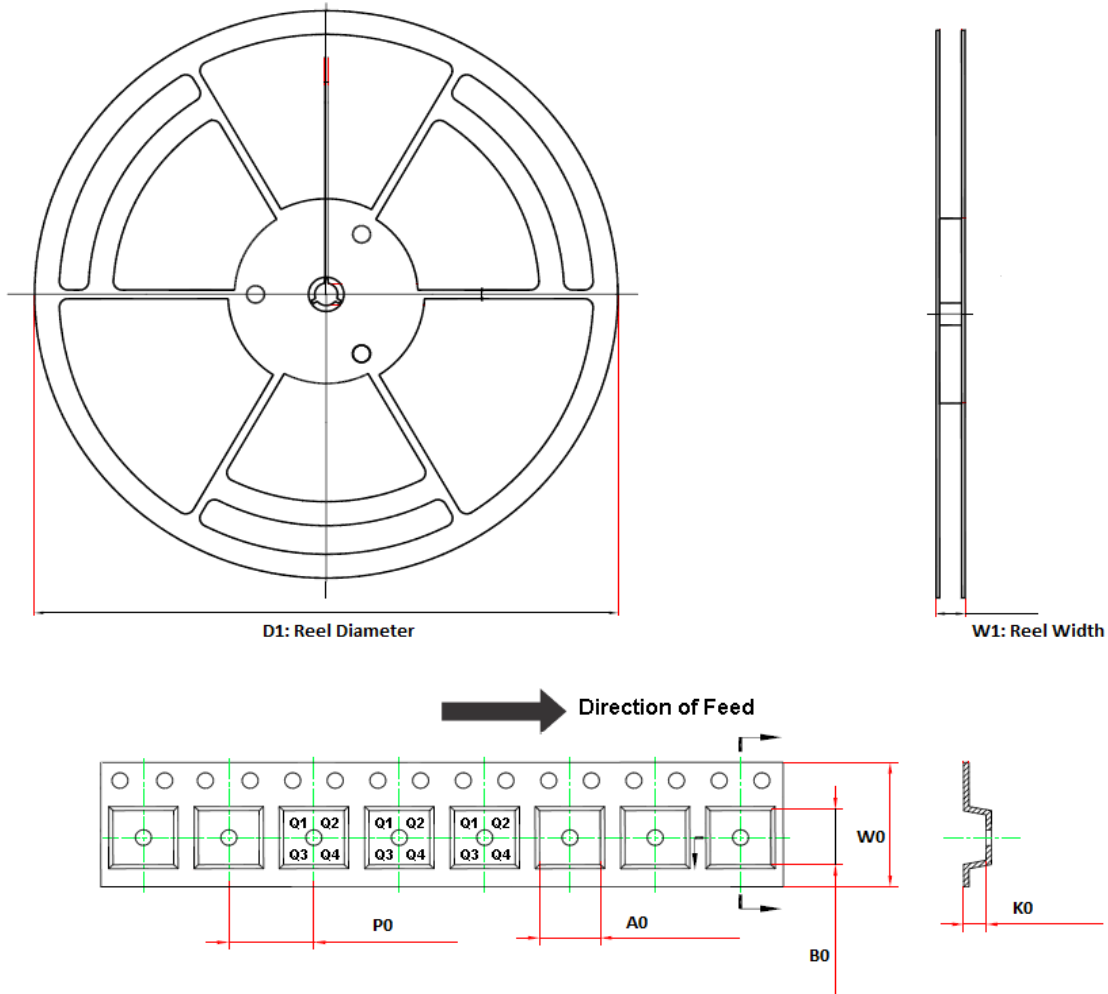

Order Number	Package	D1 (mm)	W1 (mm)	A0 (mm)	B0 (mm)	K0 (mm)	P0 (mm)	W0 (mm)	Pin1 Quadrant
TPL810ADJ-5TR	SOT23-5	180	13.1	3.2	3.2	1.4	4	8	Q3
TPL810Fxx-89TR	SOT89-3	330	17.6	4.8	4.4	1.8	8	12	Q3
TPL810Uxx-89TR	SOT89-3	330	17.6	4.8	4.4	1.8	8	12	Q3
TPL810Fxx-5TR	SOT23-5	180	13.1	3.2	3.2	1.4	4	8	Q3
TPL810Uxx-5TR	SOT23-5	180	13.1	3.2	3.2	1.4	4	8	Q3
TPL810Fxx-3TR	SOT23-3	180	13.1	3.18	3.28	1.32	4	8	Q3

(1) Output voltage value, xx = 2.8 to 50, e.g., 33 means 3.3 V output voltage.

24-V Input, 180-mA Output
High Voltage and Low Quiescent Current LDO

Package Outline Dimensions

SOT89-3

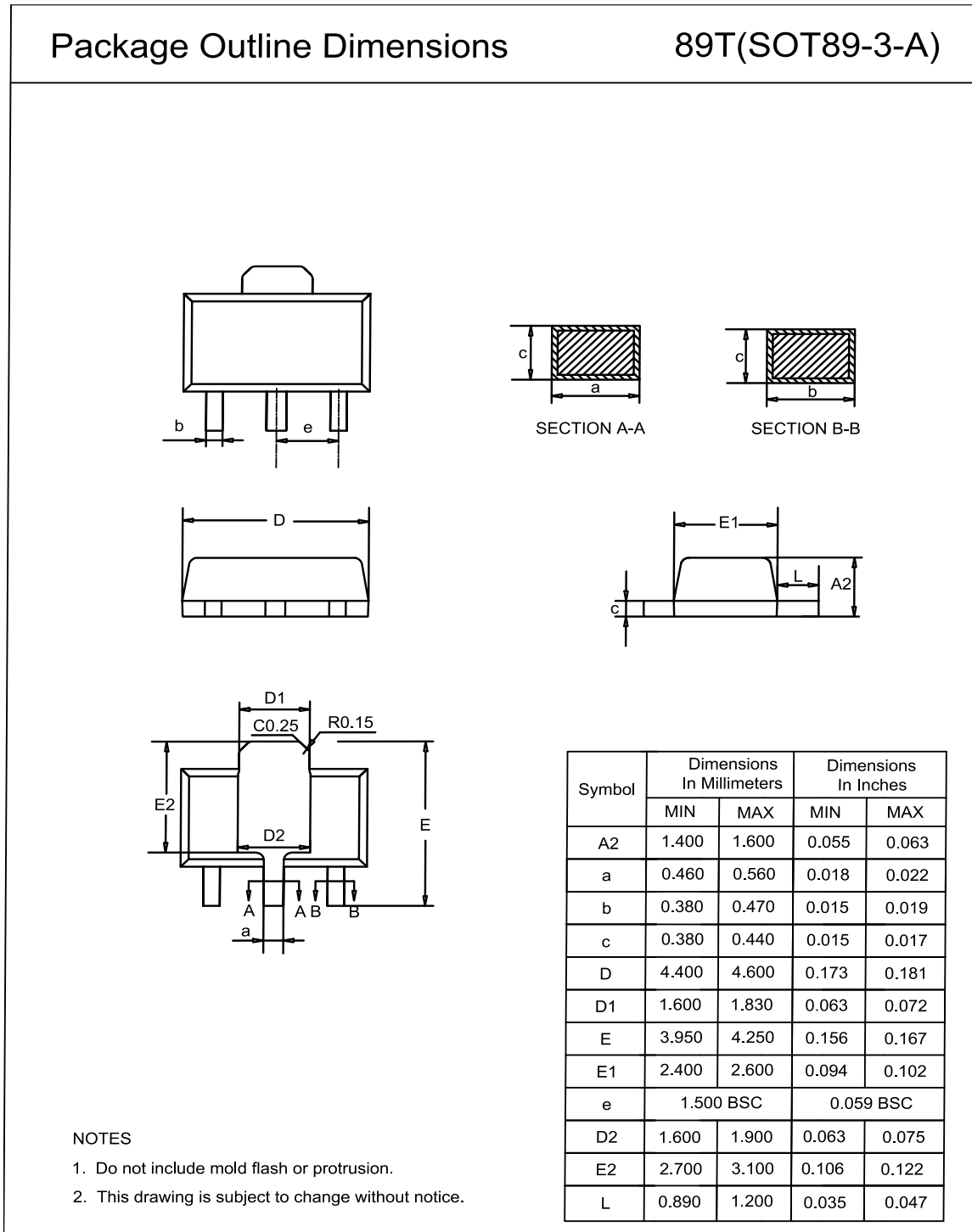

24-V Input, 180-mA Output
High Voltage and Low Quiescent Current LDO

SOT23-5

Package Outline Dimensions

S5T(SOT23-5-A)

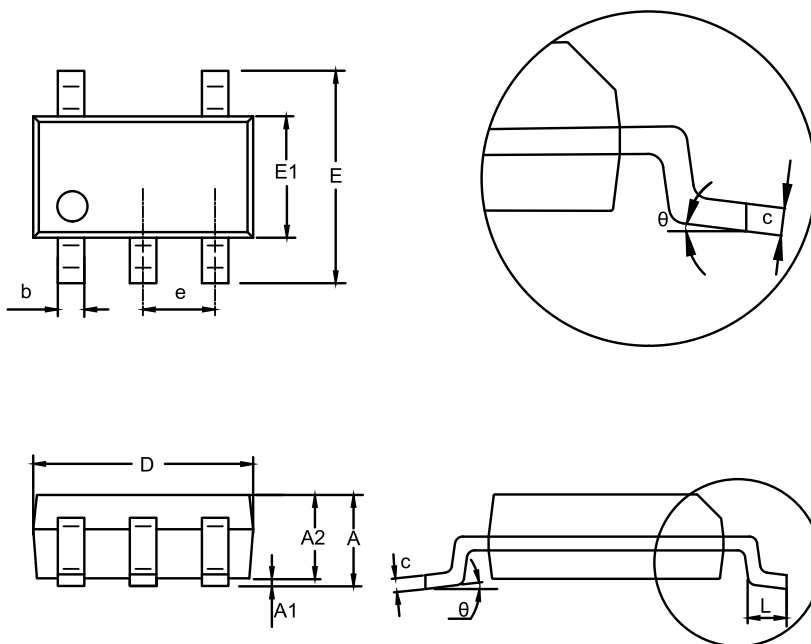

Symbol	Dimensions In Millimeters		Dimensions In Inches	
	MIN	MAX	MIN	MAX
A	1.050	1.250	0.041	0.049
A1	0.000	0.150	0.000	0.006
A2	1.000	1.200	0.039	0.047
b	0.280	0.500	0.011	0.020
c	0.100	0.230	0.004	0.009
D	2.820	3.020	0.111	0.119
E	2.600	3.000	0.102	0.118
E1	1.500	1.720	0.059	0.068
e	0.950 BSC		0.037 BSC	
L	0.300	0.600	0.012	0.024
θ	0	8°	0	8°

NOTES

1. Do not include mold flash or protrusion.
2. This drawing is subject to change without notice.

24-V Input, 180-mA Output
High Voltage and Low Quiescent Current LDO

SOT23-3

Package Outline Dimensions

S3T(SOT23-3-A)

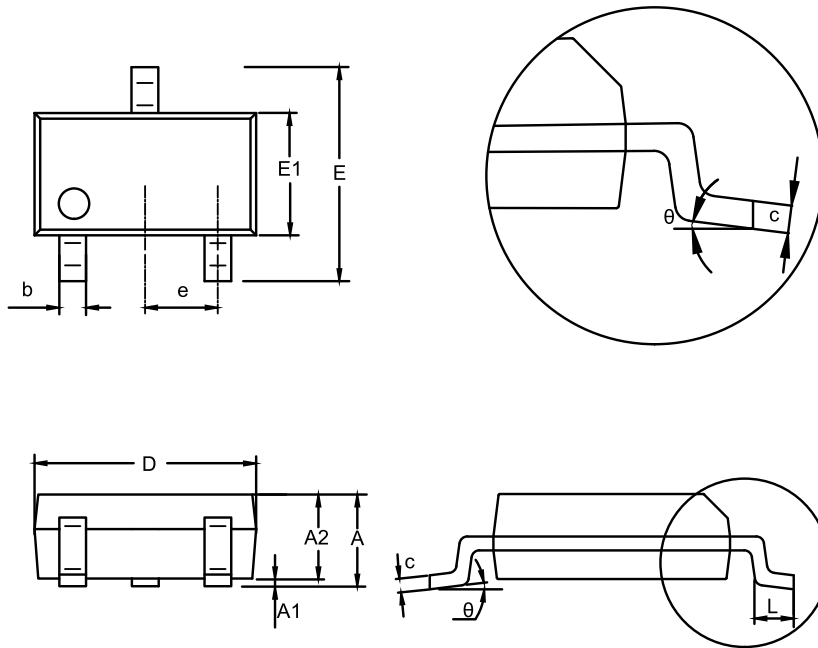

Symbol	Dimensions In Millimeters		Dimensions In Inches	
	MIN	MAX	MIN	MAX
A	1.050	1.250	0.041	0.049
A1	0.000	0.150	0.000	0.006
A2	1.000	1.200	0.039	0.047
b	0.280	0.500	0.011	0.020
c	0.100	0.230	0.004	0.009
D	2.820	3.020	0.111	0.119
E	2.600	3.000	0.102	0.118
E1	1.500	1.720	0.059	0.068
e	0.950 BSC		0.037 BSC	
L	0.300	0.600	0.012	0.024
θ	0	8°	0	8°

NOTES

1. Do not include mold flash or protrusion.
2. This drawing is subject to change without notice.

Order Information

Order Number	Junction Temperature Range	Package	Marking Information	MSL	Transport Media, Quantity	Eco Plan
TPL810ADJ-5TR	-40 to 125°C	SOT23-5	L4A	MSL3	Tape and Reel, 3,000	Green
TPL810F28-89TR	-40 to 125°C	SOT89-3	L4H	MSL3	Tape and Reel, 4,000	Green
TPL810F30-89TR	-40 to 125°C	SOT89-3	L4I	MSL3	Tape and Reel, 4,000	Green
TPL810F33-89TR	-40 to 125°C	SOT89-3	L4J	MSL3	Tape and Reel, 4,000	Green
TPL810F50-89TR	-40 to 125°C	SOT89-3	L4K	MSL3	Tape and Reel, 4,000	Green
TPL810F28-5TR ⁽¹⁾	-40 to 125°C	SOT23-5	L4H	MSL3	Tape and Reel, 3,000	Green
TPL810F30-5TR ⁽¹⁾	-40 to 125°C	SOT23-5	L4I	MSL3	Tape and Reel, 3,000	Green
TPL810F33-5TR	-40 to 125°C	SOT23-5	L4J	MSL3	Tape and Reel, 3,000	Green
TPL810F50-5TR	-40 to 125°C	SOT23-5	L4K	MSL3	Tape and Reel, 3,000	Green
TPL810U28-5TR ⁽¹⁾	-40 to 125°C	SOT23-5 (B)	L4O	MSL3	Tape and Reel, 3,000	Green
TPL810U30-5TR ⁽¹⁾	-40 to 125°C	SOT23-5 (B)	L4P	MSL3	Tape and Reel, 3,000	Green
TPL810U33-5TR	-40 to 125°C	SOT23-5 (B)	L4Q	MSL3	Tape and Reel, 3,000	Green
TPL810U50-5TR	-40 to 125°C	SOT23-5 (B)	L4R	MSL3	Tape and Reel, 3,000	Green
TPL810F28- 3TR ⁽¹⁾	-40 to 125°C	SOT23-3	L4H	MSL3	Tape and Reel, 3,000	Green
TPL810F30- 3TR	-40 to 125°C	SOT23-3	L4I	MSL3	Tape and Reel, 3,000	Green
TPL810F33- 3TR	-40 to 125°C	SOT23-3	L4J	MSL3	Tape and Reel, 3,000	Green
TPL810F50- 3TR	-40 to 125°C	SOT23-3	L4K	MSL3	Tape and Reel, 3,000	Green

(1) Future product, contact 3PEAK factory for more information and sample

(2) Green: 3PEAK defines "Green" to mean RoHS compatible and free of halogen substances.

IMPORTANT NOTICE AND DISCLAIMER

Copyright© 3PEAK 2012-2023. All rights reserved.

Trademarks. Any of the 思瑞浦 or 3PEAK trade names, trademarks, graphic marks, and domain names contained in this document /material are the property of 3PEAK. You may NOT reproduce, modify, publish, transmit or distribute any Trademark without the prior written consent of 3PEAK.

Performance Information. Performance tests or performance range contained in this document/material are either results of design simulation or actual tests conducted under designated testing environment. Any variation in testing environment or simulation environment, including but not limited to testing method, testing process or testing temperature, may affect actual performance of the product.

Disclaimer. 3PEAK provides technical and reliability data (including data sheets), design resources (including reference designs), application or other design recommendations, networking tools, security information and other resources "As Is". 3PEAK makes no warranty as to the absence of defects, and makes no warranties of any kind, express or implied, including without limitation, implied warranties as to merchantability, fitness for a particular purpose or non-infringement of any third-party's intellectual property rights. Unless otherwise specified in writing, products supplied by 3PEAK are not designed to be used in any life-threatening scenarios, including critical medical applications, automotive safety-critical systems, aviation, aerospace, or any situations where failure could result in bodily harm, loss of life, or significant property damage. 3PEAK disclaims all liability for any such unauthorized use.