

## 42-V 300-mA Wide-input Ultra-low Quiescent Current Low-Dropout Linear Regulator

### Features

- Qualified for Automotive Applications
  - AEC-Q100 Grade 1,  $T_A$ :  $-40^{\circ}\text{C}$  to  $+125^{\circ}\text{C}$
  - Junction Temperature,  $T_J$ :  $-40^{\circ}\text{C}$  to  $+150^{\circ}\text{C}$
- Input Voltage: 3 V to 42 V
- Output Voltage:
  - Fixed 5 V and 3.3 V
- $\pm 2\%$  Output Accuracy Over Line Regulation, Load Regulation, and Operating Temperature Range
- Low Current Consumption:
  - 400-nA Shutdown Current
  - 3- $\mu\text{A}$  Typical Quiescent Current
- 300-mA Maximum Output Current
- Low Dropout Voltage: 720 mV Maximum at 200 mA Load Current
- Stable with 1- $\mu\text{F}$  to 200- $\mu\text{F}$  Output Capacitor with ESR Range from 0.001  $\Omega$  to 10  $\Omega$
- Integrated Protection:
  - Over-Current Protection
  - Over-Temperature Protection
- Package Options:
  - DFN3X3-8
  - EMSOP-8

### Applications

- Automotive Clusters and Infotainment
- Automotive Headlights and Interior Lighting
- Automotive Domain Control
- Automotive BCM and Door Handler

### Description

The TPL8035Q series supports operating with 3 V to 42 V (45-V maximum transient voltage). Operating with as low as 3 V allows the TPL8035Q to continue to work well during cold-crank and start-stop conditions.

The TPL8035Q products are 3- $\mu\text{A}$  ultra-low quiescent low dropout voltage linear regulators with 300-mA maximum output current capability.

With the above features, the TPL8035Q products are the optimal solutions for powering the MCU, CAN/LIN transceivers in the always-on applications, and the battery-connected applications in the automotive systems.

The TPL8035Q series provides fixed 5-V and 3.3-V output voltage options. What's more, the TPL8035Q supports a wide range of output capacitors from 1  $\mu\text{F}$  to 200  $\mu\text{F}$  with an ESR range from 0.001  $\Omega$  to 10  $\Omega$ . The TPL8035Q series integrates over-current protection and over-temperature protection.

The TPL8035Q series operates in the ambient temperature range from  $-40^{\circ}\text{C}$  to  $+125^{\circ}\text{C}$ . Additionally, the TPL8035Q series provides a thermal-enhanced package of DFN3X3-8 to enable sustained operation despite significant dissipation.

### Typical Application Circuit

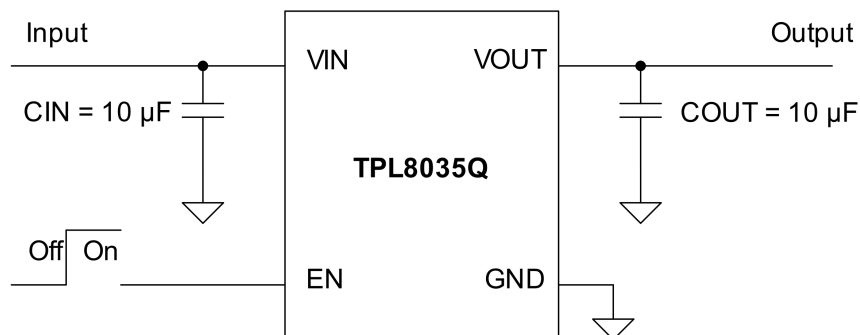

**Table of Contents**

<b>Features</b> .....	<b>1</b>
<b>Applications</b> .....	<b>1</b>
<b>Description</b> .....	<b>1</b>
<b>Typical Application Circuit</b> .....	<b>1</b>
<b>Product Family Table</b> .....	<b>3</b>
<b>Revision History</b> .....	<b>3</b>
<b>Pin Configuration and Functions</b> .....	<b>4</b>
<b>Specifications</b> .....	<b>5</b>
Absolute Maximum Ratings .....	5
ESD, Electrostatic Discharge Protection.....	5
Recommended Operating Conditions.....	5
Thermal Information.....	5
Electrical Characteristics.....	6
Typical Performance Characteristics.....	7
<b>Detailed Description</b> .....	<b>10</b>
Overview.....	10
Functional Block Diagram.....	10
Feature Description.....	10
<b>Application and Implementation</b> .....	<b>12</b>
Application Information .....	12
Typical Application.....	12
<b>Layout</b> .....	<b>14</b>
Layout Guideline.....	14
Layout Example.....	14
<b>Tape and Reel Information</b> .....	<b>15</b>
<b>Package Outline Dimensions</b> .....	<b>17</b>
DFN3X3-8.....	17
EMSOP8.....	18
<b>Order Information</b> .....	<b>19</b>
<b>IMPORTANT NOTICE AND DISCLAIMER</b> .....	<b>20</b>

---

**42-V 300-mA Wide-input Ultra-low Quiescent Current Low-Dropout  
Linear Regulator****Product Family Table**

Order Number	Output Voltage (V)	Package
TPL803533Q-DF6R-S	3.3 V	DFN3X3-8
TPL803550Q-DF6R-S	5.0 V	DFN3X3-8
TPL803533Q-EV1R-S	3.3 V	EMSOP8
TPL803550Q-EV1R-S	5.0 V	EMSOP8

**Revision History**

Date	Revision	Notes
2023-12-24	Rev.Pre.0	Preliminary datasheet.
2024-09-27	Rev.A.0	Initial released.

# 42-V 300-mA Wide-input Ultra-low Quiescent Current Low-Dropout Linear Regulator

## Pin Configuration and Functions



**Table 1. Pin Functions: TPL8035Q-S**

Pin No.		Pin Name	I/O	Description
DFN3X3-8	EMSOP8			
2	2	EN	I	Regulator enable pin. Drive EN high to turn on the regulator; drive EN low to turn off the regulator.
4	4	GND	-	Ground reference pin. Connect the GND pin to PCB ground plane directly.
1	1	IN	I	Input voltage pin.
3, 5, 6, 7	3, 5, 6, 7	NC	-	No connection.
8	8	OUT	O	Regulated output voltage pin.

(1) Thermal Pad **MUST** be connected to PCB ground plane directly.

## 42-V 300-mA Wide-input Ultra-low Quiescent Current Low-Dropout Linear Regulator

### Specifications

#### Absolute Maximum Ratings

Parameter		Min	Max	Unit
EN, IN		-0.3	45	V
OUT		-0.3	6	V
T <sub>J</sub>	Junction Temperature Range	-40	150	°C
T <sub>STG</sub>	Storage Temperature Range	-65	150	°C
T <sub>L</sub>	Lead Temperature (Soldering 10 sec)		260	°C

- (1) Stresses beyond those listed under Absolute Maximum Ratings may cause permanent damage to the device. Exposure to any Absolute Maximum Rating condition for extended periods may affect device reliability and lifetime.  
(2) All voltage values are with respect to GND.

#### ESD, Electrostatic Discharge Protection

Symbol	Parameter	Condition	Minimum Level	Unit
HBM	Human Body Model ESD	AEC Q100-002	±2	kV
CDM	Charged Device Model ESD	AEC Q100-011	±1	kV

#### Recommended Operating Conditions

Parameter		Min	Max	Unit
IN		3	42	V
EN		0	V <sub>IN</sub>	V
C <sub>OUT</sub>	Output Capacitor Requirements	1	200	μF
ESR	Output Capacitor ESR Requirements	0.001	10	Ω
T <sub>A</sub>	Ambient Temperature Range	-40	125	°C
T <sub>J</sub>	Junction Temperature Range	-40	150	°C

#### Thermal Information

Package Type	θ <sub>JA</sub>	θ <sub>JB</sub>	θ <sub>JC,top</sub>	θ <sub>JC,bottom</sub>	Unit
DFN3X3-8	45.0	42.0	88.8	10.7	°C/W
EMSOP8	45.6	43.3	95.2	12.8	°C/W

## 42-V 300-mA Wide-input Ultra-low Quiescent Current Low-Dropout Linear Regulator

### Electrical Characteristics

All test conditions:  $V_{IN} = 13.5\text{ V}$ ,  $V_{EN} = 2\text{ V}$ ,  $C_{IN} = C_{OUT} = 10\text{ }\mu\text{F}$ ,  $I_{OUT} = 0.1\text{ mA}$ .  $T_A = -40^\circ\text{C}$  to  $+125^\circ\text{C}$ , unless otherwise noted.

Symbol	Parameter	Conditions	Min	Typ	Max	Unit
<b>Supply Input Voltage and Current</b>						
$V_{IN}$	Input Supply Voltage Range <sup>(1)</sup>		$V_{IN, MIN}$		42	V
UVLO	$V_{IN}$ Under-Voltage Lockout Threshold	$V_{IN}$ rising, $V_{EN} = 2\text{ V}$ , $I_{OUT} = 200\text{ mA}$		2.6	2.8	V
	Hysteresis			260		mV
$I_{SD}$	Shutdown Current	$V_{EN} = 0\text{ V}$		0.4	2	$\mu\text{A}$
$I_Q$	Quiescent Current	$I_{OUT} = 0\text{ mA}$		3	5.5	$\mu\text{A}$
		$I_{OUT} = 0.1\text{ mA}$		4	6.5	$\mu\text{A}$
<b>Enable Input Voltage and Current</b>						
$V_{IH, EN}$	EN Logic Input High (Enable)		1.4		$V_{IN}$	V
$V_{IL, EN}$	EN Logic Input Low (Disable)		0		0.7	V
$I_{EN}$	EN Pin Leakage Current	$V_{EN} = 2\text{ V}$ to $42\text{ V}$	-200		200	nA
<b>Regulated Output Voltage and Current</b>						
$V_{OUT}$	Output Accuracy	$V_{IN} = 6\text{ V}$ to $42\text{ V}$ , $I_{OUT} = 1\text{ mA}$ to $300\text{ mA}$	-2%		2%	
$\Delta V_{OUT}$	Line Regulation	$V_{IN} = 6\text{ V}$ to $42\text{ V}$ , $I_{OUT} = 10\text{ mA}$		0.1		mV
	Load Regulation	$I_{OUT} = 1\text{ mA}$ to $300\text{ mA}$		5		mV
$V_{DO}$	Dropout Voltage <sup>(2)</sup>	$I_{OUT} = 100\text{ mA}$ , $V_{OUT} = 3.3\text{ V}$		280	450	mV
		$I_{OUT} = 200\text{ mA}$ , $V_{OUT} = 3.3\text{ V}$		580	900	mV
		$I_{OUT} = 100\text{ mA}$ , $V_{OUT} = 5\text{ V}$		220	360	mV
		$I_{OUT} = 200\text{ mA}$ , $V_{OUT} = 5\text{ V}$		440	720	mV
$I_{OUT}$	Output Current Range	$V_{OUT}$ in regulation	0		300	mA
$I_{CL}$	Output Current Limit	$V_{OUT}$ is forced to $0.9 \times V_{OUT, NOM}$	320	500	900	mA
$t_{SU}$	Start-Up Time <sup>(3)</sup>			2		ms
PSRR	Power Supply Rejection Ratio <sup>(3)</sup>	$I_{OUT} = 10\text{ mA}$ , $f = 1\text{ kHz}$		65		dB
		$I_{OUT} = 10\text{ mA}$ , $f = 100\text{ kHz}$		50		dB
		$I_{OUT} = 10\text{ mA}$ , $f = 1\text{ MHz}$		40		dB
<b>Temperature Range</b>						
$T_{SD}$	Thermal Shutdown Threshold			175		$^\circ\text{C}$
	Thermal Shutdown Hysteresis			20		$^\circ\text{C}$

(1)  $V_{IN, MIN} = 3\text{ V}$  or  $V_{OUT, NOM} + 1\text{ V}$ , whichever is greater.

(2) Dropout voltage is the minimum input-to-output voltage differential needed to maintain regulation at a specified output current. Dropout voltage is measured when the output voltage has dropped 100 mV from the nominal value. In dropout, the output voltage will be equal to  $(V_{IN} - V_{DO})$ .

(3) Not tested during production.

# 42-V 300-mA Wide-input Ultra-low Quiescent Current Low-Dropout Linear Regulator

## Typical Performance Characteristics

All test conditions:  $V_{IN} = 13.5\text{ V}$ ,  $V_{EN} = 2\text{ V}$ ,  $C_{IN} = C_{OUT} = 10\text{ }\mu\text{F}$ ,  $I_{OUT} = 0.1\text{ mA}$ .  $T_A = -40^\circ\text{C}$  to  $+125^\circ\text{C}$ , unless otherwise noted.

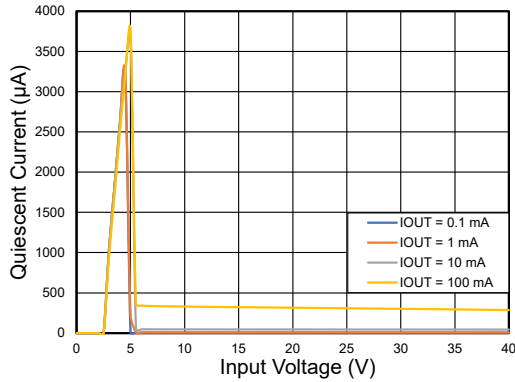

$V_{OUT} = 5\text{ V}$

**Figure 1. Quiescent Current vs Input Voltage**

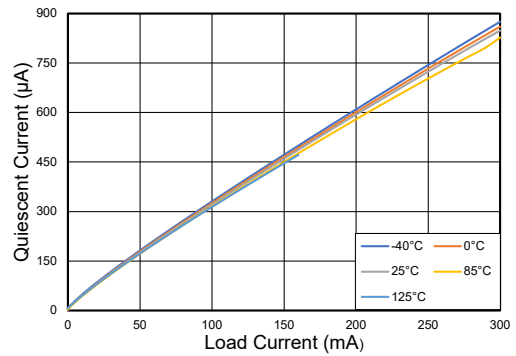

$V_{OUT} = 5\text{ V}$

**Figure 2. Quiescent Current vs Load Current**

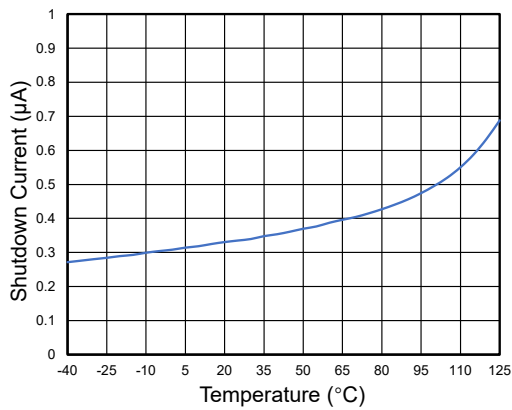

$V_{EN} = 0\text{ V}$

**Figure 3. Shutdown Current vs Ambient Temperature**

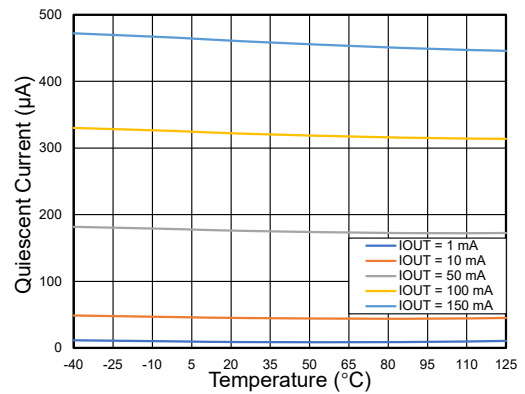

$V_{OUT} = 5\text{ V}$

**Figure 4. Quiescent Current vs Ambient Temperature**

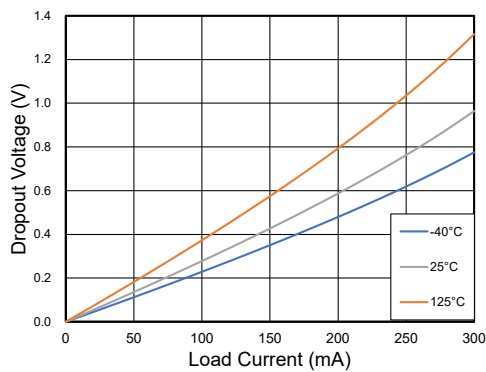

$V_{OUT} = 3.3\text{ V}$

**Figure 5. Dropout Voltage vs Load Current**

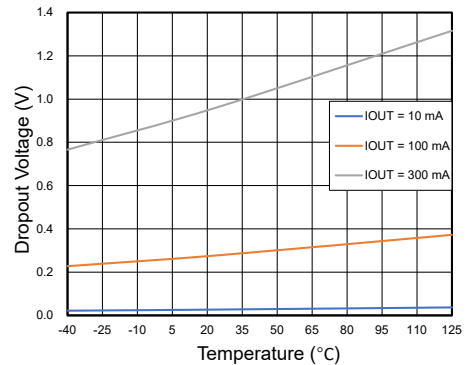

$V_{OUT} = 3.3\text{ V}$

**Figure 6. Dropout Voltage vs Ambient Temperature**

# 42-V 300-mA Wide-input Ultra-low Quiescent Current Low-Dropout Linear Regulator

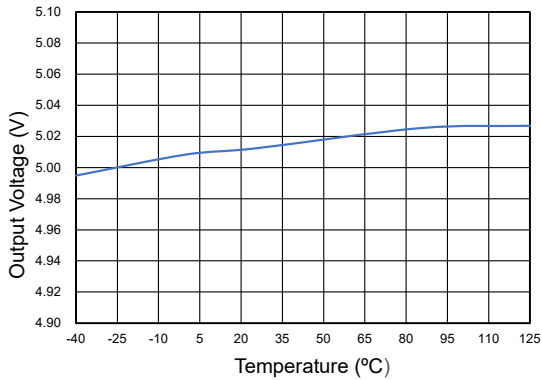

$V_{OUT} = 5\text{ V}$

**Figure 7. Output Voltage vs Ambient Temperature**

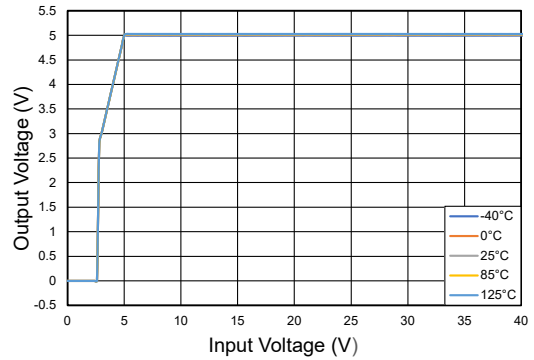

$V_{OUT} = 5\text{ V}, I_{OUT} = 1\text{ mA}$

**Figure 8. Output Voltage vs Input Voltage**

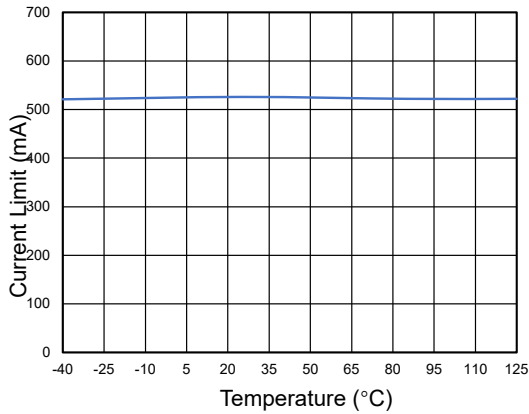

$V_{OUT} = 5\text{ V}, \text{force } V_{OUT} = 0.9 \times V_{OUT, \text{NOM}}$

**Figure 9. Output Current Limit vs Ambient temperature**

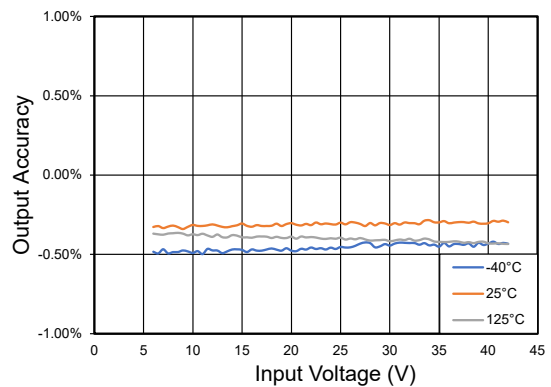

$V_{OUT} = 5\text{ V}$

**Figure 10. Line Regulation**

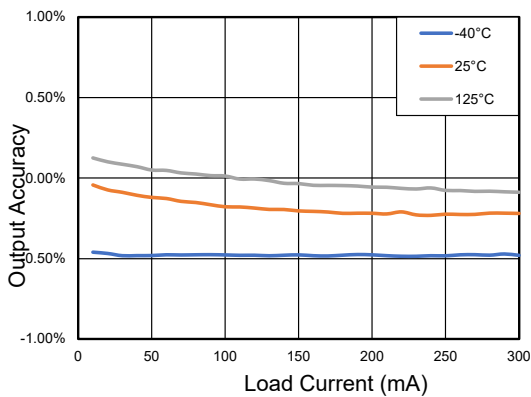

$V_{OUT} = 5\text{ V}$

**Figure 11. Load Regulation**

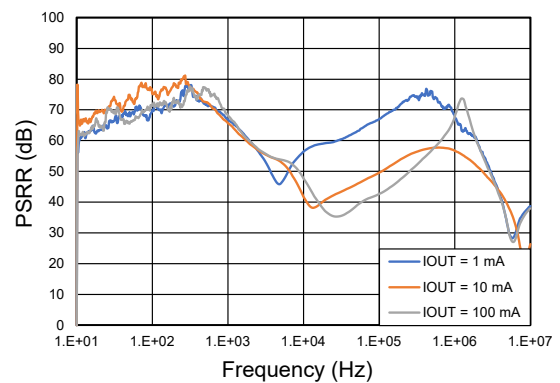

$V_{OUT} = 5\text{ V}$

**Figure 12. PSRR**



42-V 300-mA Wide-input Ultra-low Quiescent Current Low-Dropout Linear Regulator

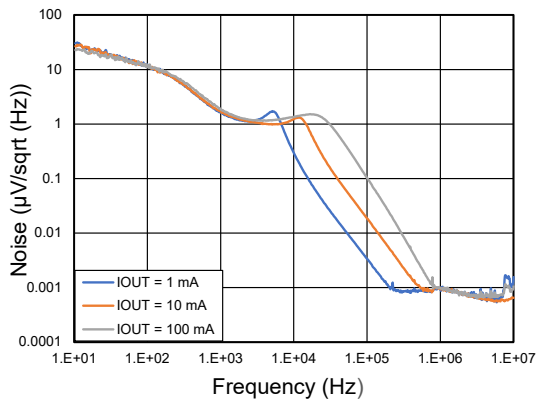

$V_{OUT} = 5\text{ V}$

Figure 13. Noise

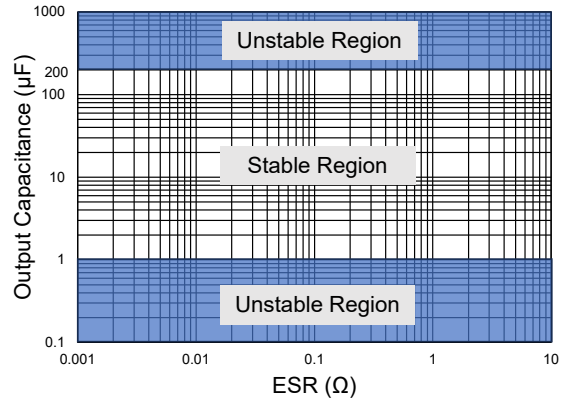
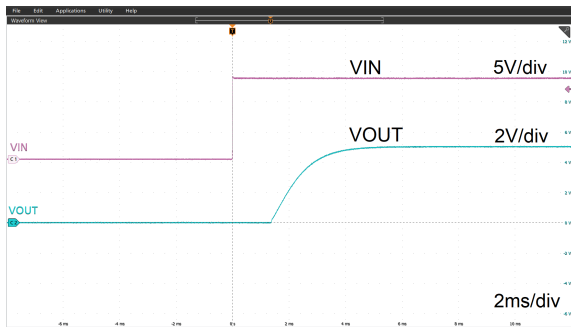
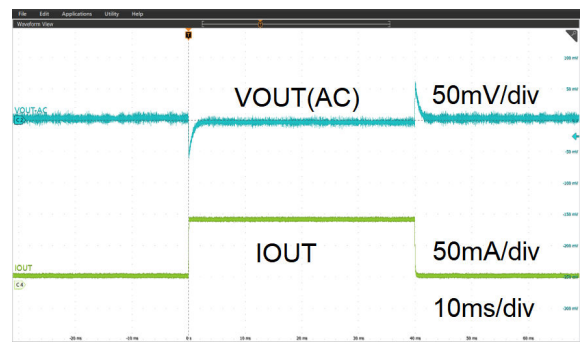

Figure 14. Output Capacitance vs ESR stability



$C_{OUT} = 10\ \mu\text{F}$ ,  $V_{IN} = 0\text{ V to }13.5\text{ V}$ ,  $V_{OUT} = 0\text{ V to }5\text{ V}$ ,  $I_{OUT} = 0.1\text{ mA}$

Figure 15. Startup Waveform



$C_{OUT} = 10\ \mu\text{F}$ ,  $I_{OUT} = 10\text{ mA to }100\text{ mA in }5\ \mu\text{s}$

Figure 16. Load Transient

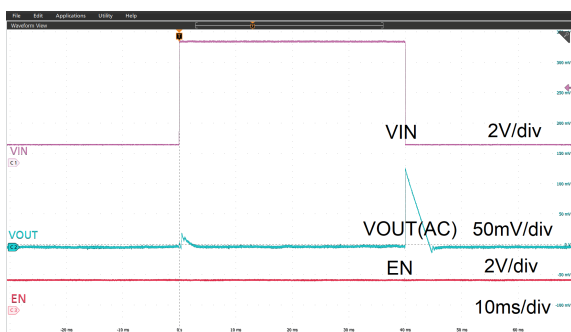

$C_{OUT} = 10\ \mu\text{F}$ ,  $V_{IN} = 6\text{ V to }40\text{ V in }30\ \mu\text{s}$

Figure 17. Line Transient

## Detailed Description

### Overview

The TPL8035Q series supports the operating range from 3 V to 42 V (45-V maximum transient voltage). Operating with as low as 3 V allows the TPL8035Q to continue to work well during cold-crank and start-stop conditions.

The TPL8035Q series products are 3- $\mu$ A ultra-low quiescent low dropout voltage linear regulators with 300-mA maximum output current capability.

With the above features, the TPL8035Q series products are the optimal solutions for powering the MCU, CAN/LIN transceivers in the always-on applications, and the battery-connected applications in automotive systems.

The TPL8035Q series provides fixed 5-V and 3.3-V output voltage options. The TPL8035Q supports a wide range of output capacitors from 1  $\mu$ F to 200  $\mu$ F with an ESR range from 0.001  $\Omega$  to 10  $\Omega$ . Also, the TPL8035Q series integrates over-current protection and over-temperature protection.

### Functional Block Diagram

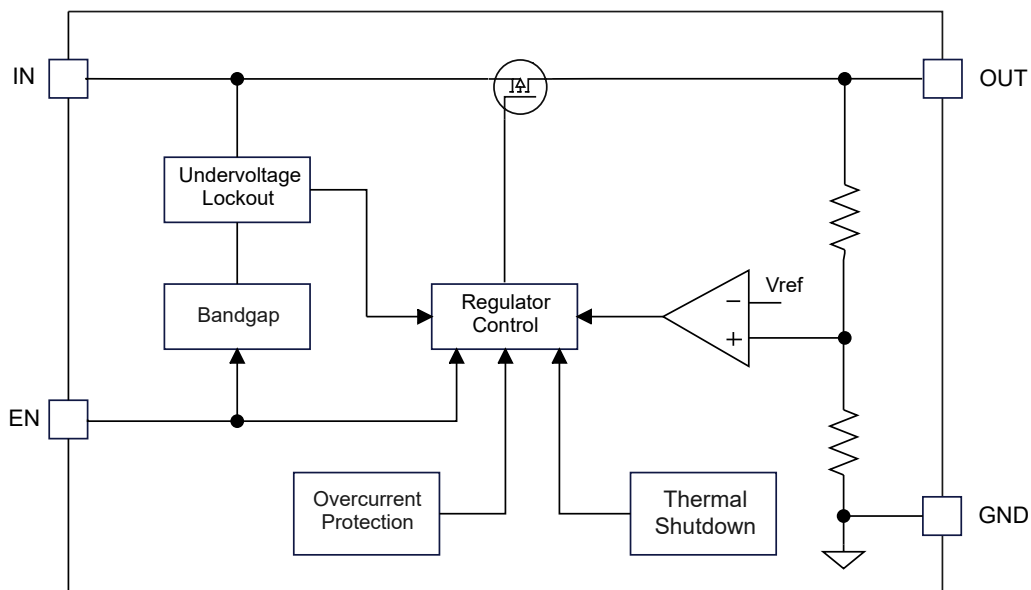

Figure 18. Functional Block Diagram

### Feature Description

#### Enable (EN)

The enable pin (EN) is active high. Connect this pin to the GPIO of an external processor or digital logic control circuit to enable and disable the device. Or connect this pin to the IN pin for self-bias applications.

---

**42-V 300-mA Wide-input Ultra-low Quiescent Current Low-Dropout  
Linear Regulator****Under-Voltage Lockout (UVLO)**

The TPL8035Q series uses an under-voltage lockout circuit to keep the output shut off until the internal circuitry operates properly. Refer to the Electrical Characteristics table for UVLO threshold and hysteresis.

**Regulated Output Voltage (OUT)**

The TPL8035Q series is available in fixed voltage versions of 5 V and 3.3 V. When the input voltage is higher than  $V_{OUT, NOM} + V_{DO}$ , the output pin is the regulated output based on the selected voltage version. When the input voltage falls below  $V_{OUT, NOM} + V_{DO}$ , the output pin tracks the input voltage minus the dropout voltage based on the load current.

**Over-Current Protection**

The TPL8035Q series integrates an internal current limit that helps to protect the regulator during fault conditions, e.g., the output is shorted to ground, or the output is forced below  $V_{OUT, NOM}$ . The output voltage is not regulated when the device is in current limit, and  $V_{OUT} = I_{CL} \times R_{LOAD}$ .

**Over-Temperature Protection**

The over-temperature protection starts to work when the junction temperature exceeds the thermal shutdown (TSD) threshold, which turns off the regulator immediately. When the device cools down and the junction temperature falls below the thermal shutdown threshold minus thermal shutdown hysteresis, the regulator turns on again.

The junction temperature range should be limited according to the Recommended Operating Conditions table, continuously operating above the junction temperature range reduces the lifetime of the device.

## Application and Implementation

### Note

Information in the following application sections is not part of the 3PEAK's component specification and 3PEAK does not warrant its accuracy or completeness. 3PEAK's customers are responsible for determining suitability of components for their purposes. Customers should validate and test their design implementation to confirm system functionality.

## Application Information

The TPL8035Q series products are 42-V 3- $\mu$ A ultra-low quiescent low dropout voltage linear regulators with 300-mA maximum output current capability. The following application schematic shows a typical usage of the TPL8035Q series.

## Typical Application

Figure 19 shows the typical application schematic of the TPL8035Q series.

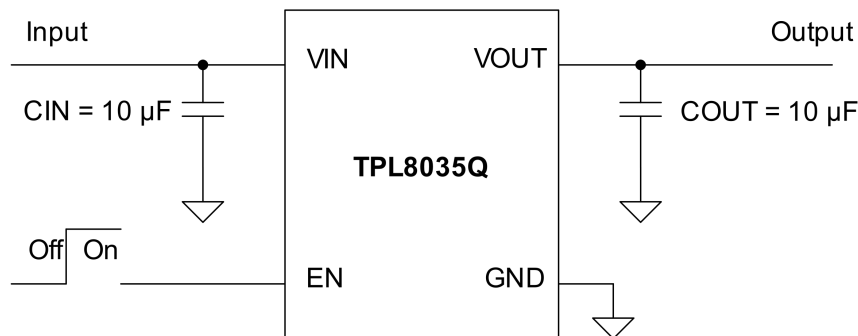

**Figure 19. Typical Application Circuit**

### Input Capacitor and Output Capacitor

The device requires an input decoupling capacitor, the value of which depends on the application. 3PEAK recommends adding a 10- $\mu$ F or greater capacitor with a 0.1- $\mu$ F bypass capacitor in parallel at the IN pin to keep the input voltage stable. The voltage rating of the capacitors must be greater than the maximum input voltage.

To ensure loop stability, the TPL8035Q series requires an output capacitor of 1  $\mu$ F to 200  $\mu$ F with an ESR range from 0.001  $\Omega$  to 10  $\Omega$ . 3PEAK recommends selecting an X7R type 10- $\mu$ F ceramic capacitor with low ESR over temperature.

Both input and output capacitors must be placed as close to the device pins as possible.

### Power Dissipation and Thermal Consideration

During normal operation, the LDO junction temperature should meet the requirement in the [Recommended Operating Conditions](#) table. Use the below equations to calculate the power dissipation and estimate the junction temperature.

The power dissipation can be calculated using the [Equation 1](#).

---

**42-V 300-mA Wide-input Ultra-low Quiescent Current Low-Dropout  
Linear Regulator**

$$P_D = (V_{IN} - V_{OUT}) \times I_{OUT} + V_{IN} \times I_{GND} \quad (1)$$

The junction temperature can be estimated using the [Equation 2](#).  $\theta_{JA}$  is the junction-to-ambient thermal resistance.

$$T_J = T_A + P_D \times \theta_{JA} \quad (2)$$

## Layout

### Layout Guideline

- Both input and output capacitors must be placed to the device pins as close as possible, and the vias between capacitors and device power pins must be avoided.
- It is recommended to bypass the input pin to ground with a 0.1- $\mu$ F bypass capacitor. The loop area formed by the bypass capacitor connection, the IN pin, and the GND pin of the system must be as small as possible.
- It is recommended to use wide and thick copper to minimize  $I \times R$  drop and heat dissipation.

### Layout Example

The following figure shows a layout example of TPL8035Q.

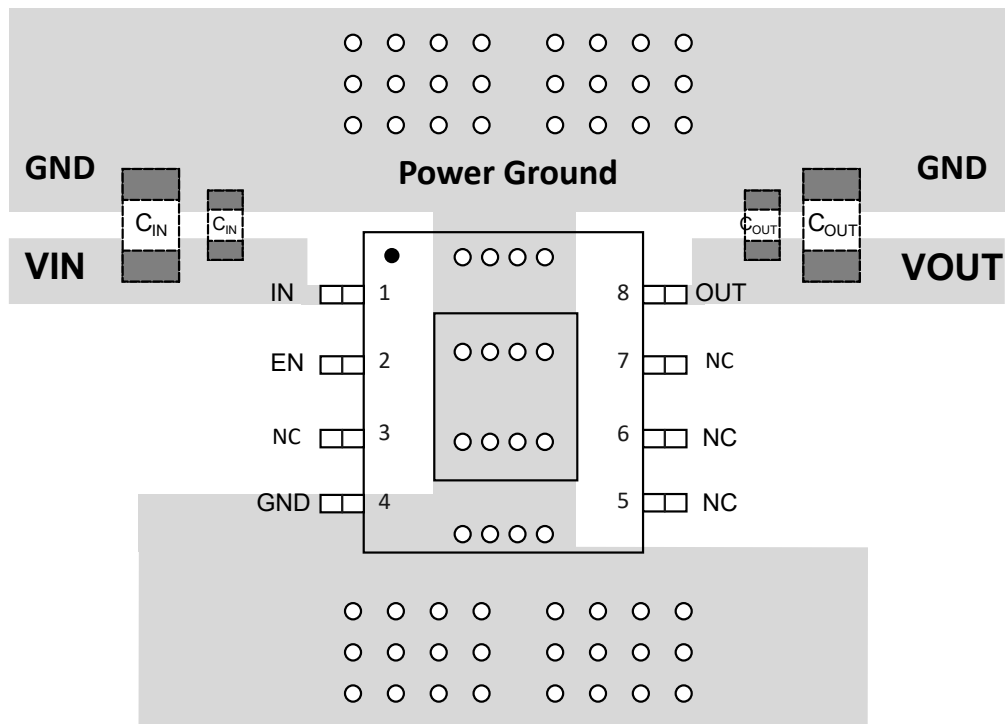
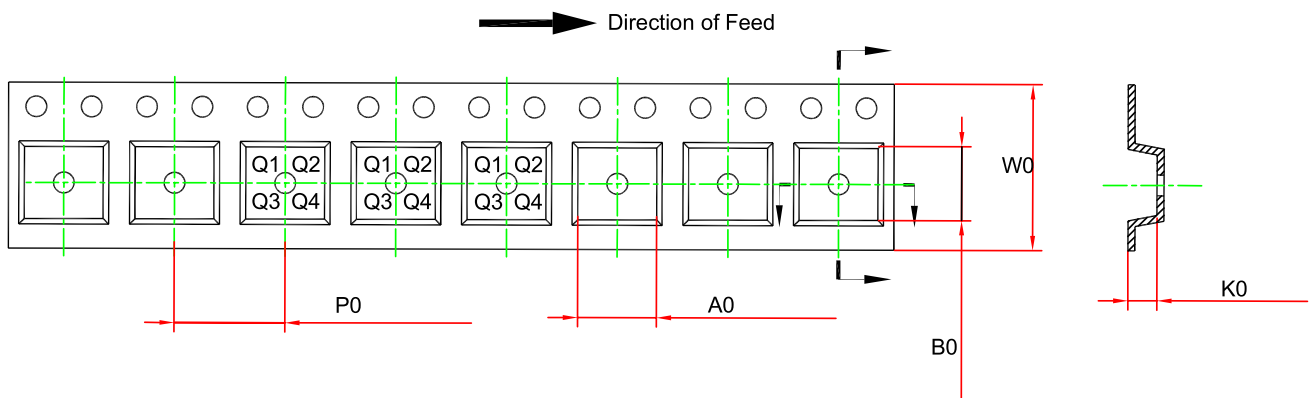
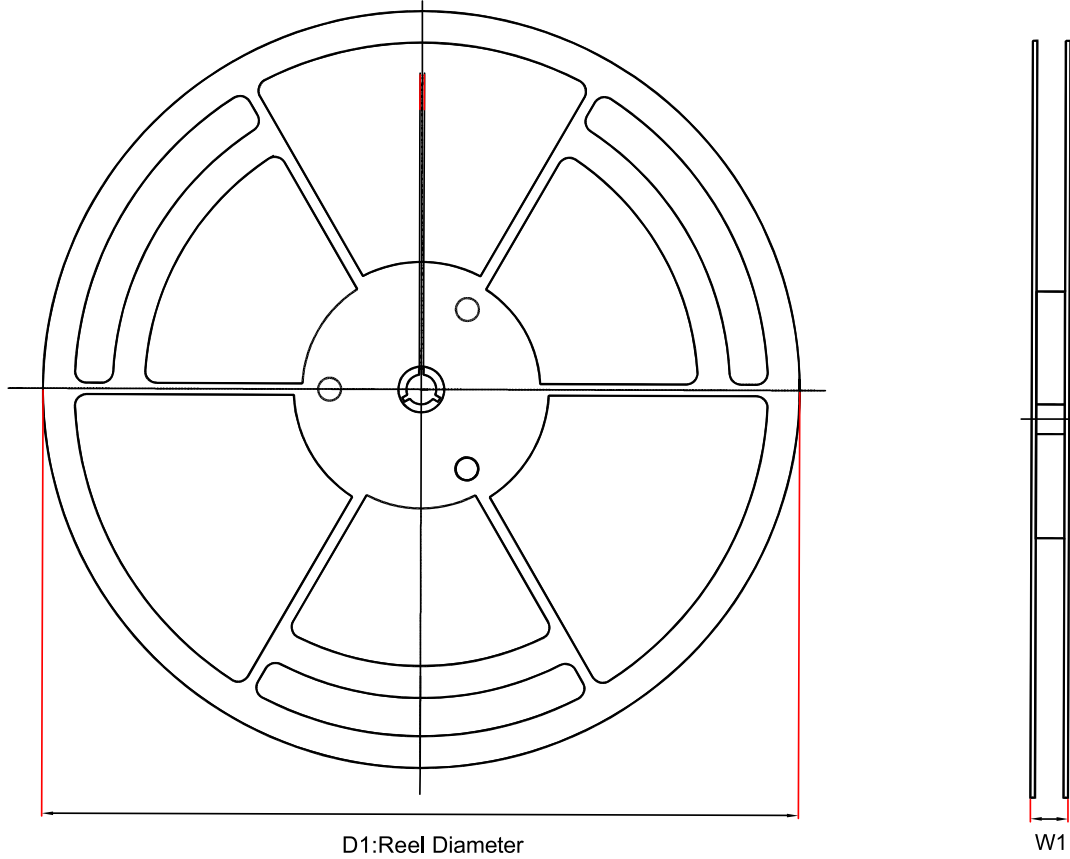

Figure 20. TPL8035Q Layout Example

## 42-V 300-mA Wide-input Ultra-low Quiescent Current Low-Dropout Linear Regulator

### Tape and Reel Information



Order Number	Package	D1 (mm)	W1 (mm)	A0 (mm)	B0 (mm)	K0 (mm)	P0 (mm)	W0 (mm)	Pin1 Quadrant
TPL803533Q-DF6R-S	DFN3X3-8	330	17.6	3.3	3.3	1.1	8	12	Q1
TPL803550Q-DF6R-S	DFN3X3-8	330	17.6	3.3	3.3	1.1	8	12	Q1

---

**42-V 300-mA Wide-input Ultra-low Quiescent Current Low-Dropout  
Linear Regulator**

Order Number	Package	D1 (mm)	W1 (mm)	A0 (mm)	B0 (mm)	K0 (mm)	P0 (mm)	W0 (mm)	Pin1 Quadrant
TPL803533Q- EV1R-S	EMSOP8	330	17.6	5.3	3.4	1.4	8	12	Q1
TPL803550Q- EV1R-S	EMSOP8	330	17.6	5.3	3.4	1.4	8	12	Q1



42-V 300-mA Wide-input Ultra-low Quiescent Current Low-Dropout Linear Regulator

Package Outline Dimensions

DFN3X3-8

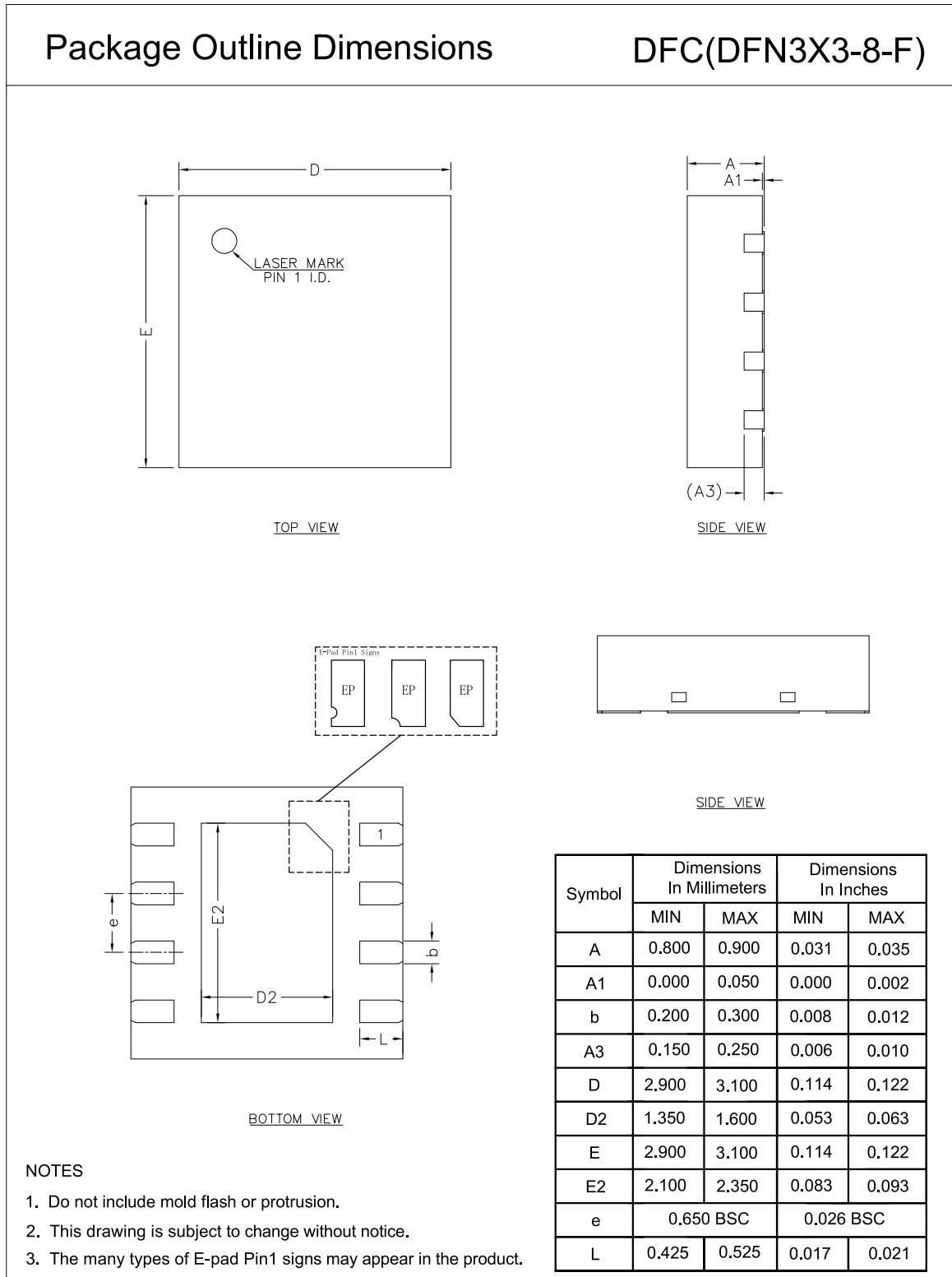

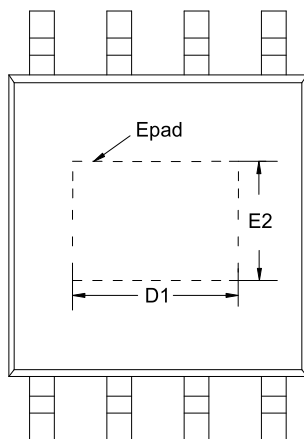
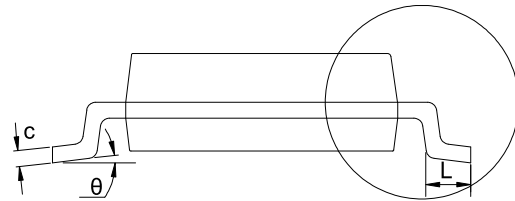
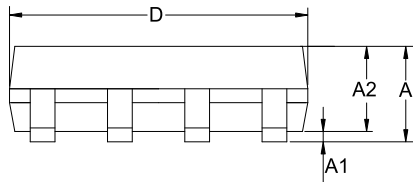
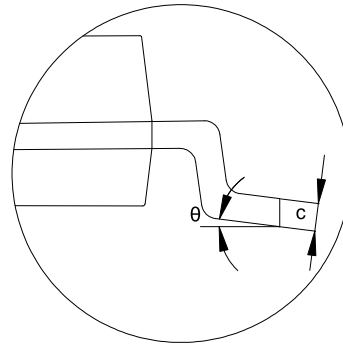
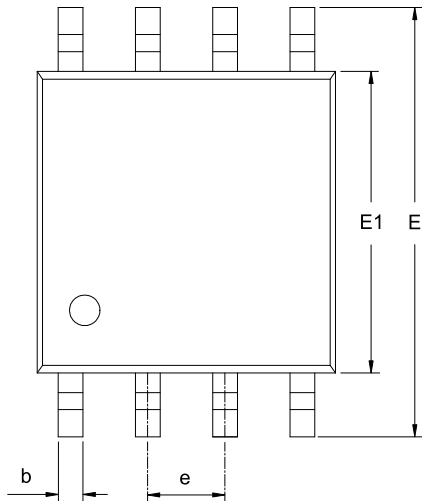
**42-V 300-mA Wide-input Ultra-low Quiescent Current Low-Dropout  
Linear Regulator**
**EMSOP8**
**Package Outline Dimensions**
**EV1(EMSOP-8-B)**

Symbol	Dimensions In Millimeters		Dimensions In Inches	
	MIN	MAX	MIN	MAX
A	0.800	1.100	0.031	0.043
A1	0.020	0.150	0.001	0.006
A2	0.750	0.950	0.030	0.037
b	0.250	0.380	0.010	0.015
c	0.090	0.230	0.004	0.009
D	2.900	3.100	0.114	0.122
D1	1.920	2.220	0.076	0.087
E	4.700	5.100	0.185	0.201
E1	2.900	3.100	0.114	0.122
E2	1.450	1.750	0.057	0.069
e	0.650 BSC		0.026 BSC	
L	0.400	0.800	0.016	0.031
$\theta$	0	8°	0	8°

**NOTES**

1. Do not include mold flash or protrusion.
2. This drawing is subject to change without notice.

---

**42-V 300-mA Wide-input Ultra-low Quiescent Current Low-Dropout Linear Regulator****Order Information**

Order Number	Operating Temperature Range	Package	Marking Information	MSL	Transport Media, Quantity	Eco Plan
TPL803533Q-DF6R-S	-40 to 150°C	DFN3X3-8	L3533	MSL2	4,000	Green
TPL803550Q-DF6R-S	-40 to 150°C	DFN3X3-8	L3550	MSL2	4,000	Green
TPL803533Q-EV1R-S	-40 to 150°C	EMSOP8	L3533	MSL2	3,000	Green
TPL803550Q-EV1R-S	-40 to 150°C	EMSOP8	L3550	MSL2	3,000	Green

**Green:** 3PEAK defines "Green" to mean RoHS compatible and free of halogen substances.

---

**42-V 300-mA Wide-input Ultra-low Quiescent Current Low-Dropout  
Linear Regulator****IMPORTANT NOTICE AND DISCLAIMER**

**Copyright**© 3PEAK 2012-2024. All rights reserved.

**Trademarks.** Any of the 思瑞浦 or 3PEAK trade names, trademarks, graphic marks, and domain names contained in this document /material are the property of 3PEAK. You may NOT reproduce, modify, publish, transmit or distribute any Trademark without the prior written consent of 3PEAK.

**Performance Information.** Performance tests or performance range contained in this document/material are either results of design simulation or actual tests conducted under designated testing environment. Any variation in testing environment or simulation environment, including but not limited to testing method, testing process or testing temperature, may affect actual performance of the product.

**Disclaimer.** 3PEAK provides technical and reliability data (including data sheets), design resources (including reference designs), application or other design recommendations, networking tools, security information and other resources "As Is". 3PEAK makes no warranty as to the absence of defects, and makes no warranties of any kind, express or implied, including without limitation, implied warranties as to merchantability, fitness for a particular purpose or non-infringement of any third-party's intellectual property rights. Unless otherwise specified in writing, products supplied by 3PEAK are not designed to be used in any life-threatening scenarios, including critical medical applications, automotive safety-critical systems, aviation, aerospace, or any situations where failure could result in bodily harm, loss of life, or significant property damage. 3PEAK disclaims all liability for any such unauthorized use.