

Low Power, 3-channel High-Definition Video Filter Driver

Features

- 3-HDTV Video Filter Support Y'Pb'Pr'-1080p /1080i/720p, R'G'B' or VGA/SVGA/XGA
- Optimized 6th-order Butterworth Video reconstruction filter:
 - HD Channel: -3dB ≥ 72MHz
- Support Multiple Input Biasing:
 - Provide 80-mV Level-Shift when DC-Coupled
 - Transparent Input Clamping when AC-Coupled
 - Support External DC Biasing when AC-Coupled
- Very Low Quiescent Current: 11.5 mA(at 3.3V, Typical)
- 6dB Gain(2V/V), Rail TO Rail Output
- AC- or DC-Coupled Output Driving Dual Video Loads (75Ω)
- Wide Power Supply: +3.0V to +5.5V Single Supply
- Robust ESD Protection:
 - Robust 8kV – HBM and 2kV – CDM ESD Rating
- Green Product, SOIC-8 Package

Applications

- Video Signal Amplification
- Set-Top Box Video Driver
- PVR、DVD Player Video Buffer
- Video Buffer for Portable or USB-Powered Video Devices
- HDTV

Description

TPF143 is a specially designed for consumer applications, high-performance, low-cost video reconstruction filter, it combine excellent video performance and low power consumption perfectly. It incorporates three high-definition (HD) filter channels. All filters feature sixth-order Butterworth characteristics that are useful as digital-to-analog converter (DAC) reconstruction filters or as analog-to-digital converter (ADC) anti-aliasing filters. The HD filters can be bypassed to support filters. The HD filters can be bypassed to support 1080p60 video or up to quad extended graphics array (QXGA) RGB video.

As part of the TP143 flexibility, the input can be configured for ac- or dc-coupled inputs. The 84-mV output level shift allows for a full sync dynamic range at the output with 0-V input. The ac-coupled modes include a transparent sync-tip clamp option for Y', and G'B'R' signals. AC- coupled biasing for C'/P'B/P'R channels can easily be achieved by adding an external resistor to VS+.

The TP143 rail-to-rail output stage with 6-dB gain allows for both ac and dc line driving. The ability to drive two lines, or 75-Ω loads, allows for maximum flexibility as a video line driver. The 34.5-mA total quiescent current at 3.3 V makes it an excellent choice for power-sensitive video applications.

TPF143 is available in SOIC-8 package. Its operation temperature range is from -40°C to +85°C.

Related Resources

AN-1201: Application notes of TPF1xx

Function Block

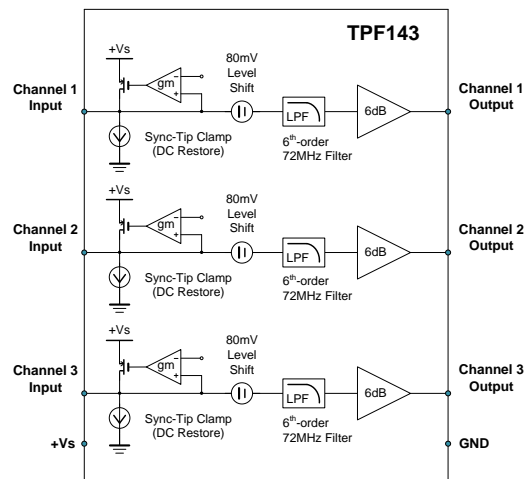

Figure 1

TPF143

Low Power, 3-channel High-Definition Video Filter Driver

Order Information

Order Number	Operating Temperature Range	Package	Package Options	Transport Media, Quantity
TPF143-SR	-40 to 85°C	SOIC-8	MSL-3	Tape and Reel, 4000

Pin configuration (Top View)

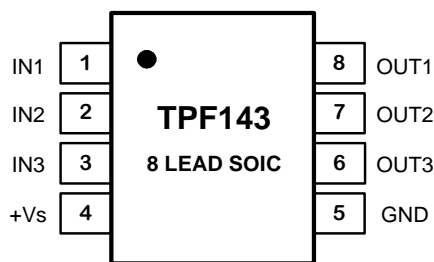

Figure 2.

Pin Number	Pin Name	Function
1	IN1	First Input
2	IN2	Second input
3	IN3	Third input
4	+Vs	Positive power supply
5	GND	Ground
6	OUT3	Third output
7	OUT2	Second output
8	OUT1	First output

Absolute Maximum Ratings*

Parameters		Value	Units
Power Supply, V_{DD} to GND		6.0	V
PD	Power Dissipation, $T_A = 25^\circ\text{C}$, 8-Lead SOIC	800 ⁽¹⁾	PD
V_{IN}	Input Voltage	$V_{DD} + 0.3\text{V}$ to GND - 0.3V	
I_O	Output Current	65	I_O
T_J	Maximum Junction Temperature	150	T_J
T_A	Operating Temperature Range	-45 to 85	T_A
T_{STG}	Storage Temperature Range	-65 to 150	T_{STG}
TL	Lead Temperature (Soldering 10 sec)	300	TL
θ_{JA}	8-Lead SOIC Thermal Resistance	130 ⁽²⁾	θ_{JA}

* **Note:** Stresses beyond those listed under Absolute Maximum Ratings may cause permanent damage to the device. Exposure to any Absolute Maximum Rating condition for extended periods may affect device reliability and lifetime.

(1) This data was taken with the JEDEC low effective thermal conductivity test board.

(2) This data was taken with the JEDEC standard multilayer test boards.

ESD, Electrostatic Discharge Protection

Symbol	Parameter	Condition	Minimum Level	Unit
HBM	Human Body Model ESD	MIL-STD-883H Method 3015.8	8	kV
CDM	Charged Device Model ESD	JEDEC-EIA/JESD22-C101E	2	kV

Electrical Characteristics All test condition is $V_{DD} = 3.3V$, $T_A = +25^{\circ}C$, $R_L = 150\Omega$ to GND, unless otherwise noted.

SYMBOL	PARAMETER	CONDITIONS	MIN	TYP	MAX	UNITS
Input Electrical Specifications						
V_{DD}	Supply Voltage Range		3.0		5.5	V
I_{CC}	Quiescent current (I_Q) ⁽¹⁾	$V_{DD} = 3.3V$, $V_{IN} = 500mV$, no load		34.5	42.8	mA
		$V_{DD} = 5.0V$, $V_{IN} = 500mV$, no load		45	55.6	mA
V_{OLS}	Output Level Shift Voltage	$V_{IN} = 0V$, no load, input referred	54	80	124	mV
$I_{CLAMP-CHG}$	Clamp Charge Current	$V_{IN} = V_{CLAMP} - 100mV$	-1.5	-1.7		mA
$I_{CLAMP-DCHG}$	Clamp Discharge Current	$V_{IN} = 500mV$	1.5	2.0	5.1	μA
V_{CLAMP}	Input Voltage Clamp	$I_{IN} = -1mA$	-40	0	+40	mV
AV	Voltage Gain	$V_{IN}=0.5V, 1V$ or $2V$ $R_L=150\Omega$ to GND	5.91	6.01	6.03	dB
PSRR	Power Supply Rejection Ratio	$\Delta V_{DD} = 3.3V$ to $3.6V$		57		dB
		$\Delta V_{DD} = 5.0V$ to $5.5V$, $50Hz$, $V_{IN}=0.7V$		61		dB
V_{OH}	Output Voltage High Swing	$V_{IN} = 3V$, $R_L = 75\Omega$ to GND (dual load)		3.18		V
V_{OL}	Output Voltage Low Swing	$V_{IN} = -0.3V$, $R_L = 75\Omega$		0.05		V
I_{SC}	Short-circuit current	$V_{IN}=2V$, output to GND through 10Ω	65			mA
		$V_{IN}=100mV$, output short to V_{DD}	65			mA
AC Electrical Specifications						
f_{-1dB}	-1dB Bandwidth	$R_L=150\Omega$	53.1	63.2	72.9	MHz
f_{-3dB}	-3dB Bandwidth	$R_L=150\Omega$	63.7	71.5	80.1	MHz
Att_{148MHz}	Stop Band Attenuation	$f = 148MHz$	34	39		dB
SR	Slew Rate	2V output step, 80% to 20%		300		V/ μs
dG	Differential Gain	Video input range 1V		0.1	1	%
dP	Differential Phase	Video input range 1V		0.3	0.6	$^{\circ}$
THD	Total Harmonic Distortion	$f=10MHz$, $V_{OUT}=1.4V_{PP}$		0.15		%
		$f=22MHz$, $V_{OUT}=1.4V_{PP}$		0.6		%
D/DT	Group Delay Variation	$f = 100kHz$ to $27MHz$		2.5		ns
		$f = 100kHz$ to $60MHz$		6.0		ns
t_{PD}	Propagation Delay	Maximum delay from input to output: ($100kHz$ to $60MHz$)		11.0	18.0	ns
X_{TALK}	Channel Crosstalk	$f = 1MHz$, $V_{OUT}=1.4V_{PP}$	-68	-74		dB
SNR	Signal-to-Noise Ration	$f= 100kHz$ to $30MHz$		67		dB
		$f= 100kHz$ to $60MHz$		64		dB
R_{OUT_AC}	Output Impedance	$f = 10MHz$		0.5		Ω

Note:

(1). 100% tested at $T_A=25^{\circ}C$.

Typical Performance Characteristics All test condition is $V_{DD} = 3.3V$, $T_A = +25^\circ C$, $R_L = 150\Omega$ to GND, unless otherwise noted.

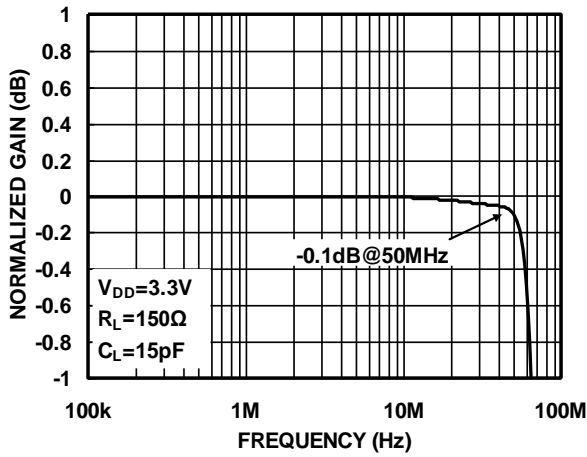

Figure3. Small-Scale Frequency Response

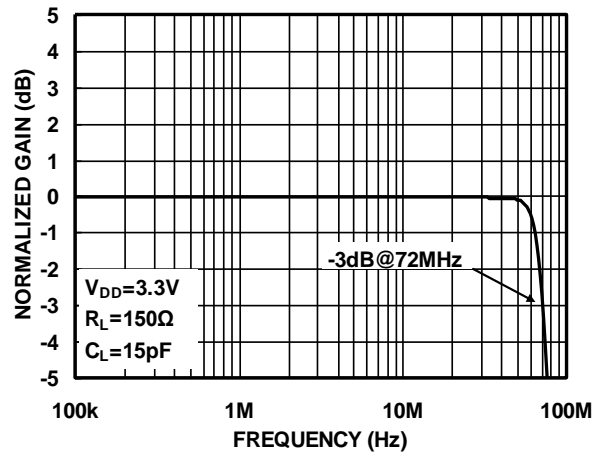

Figure4. Large-Scale Frequency Response

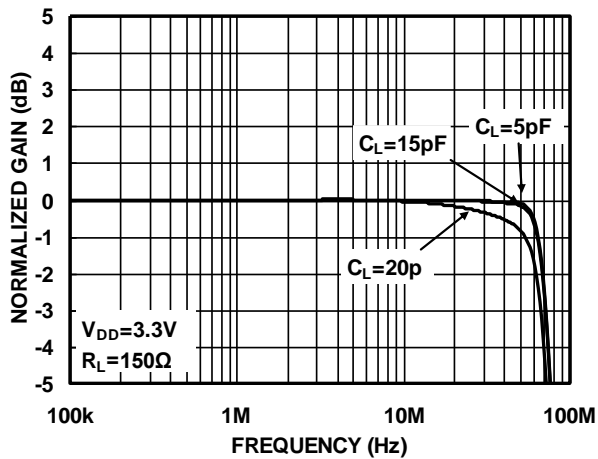

Figure5. Gain Vs. Frequency With C_{LOAD}

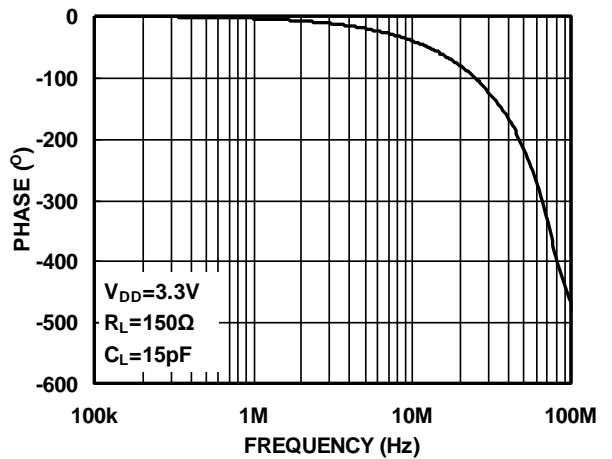

Figure6. Gain Vs. Frequency

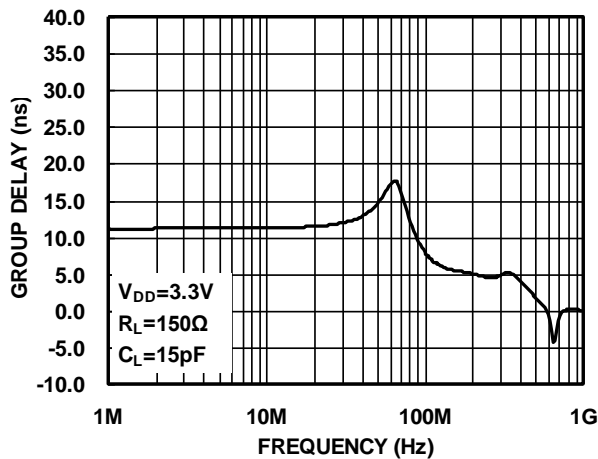

Figure7. Group Delay vs Frequency

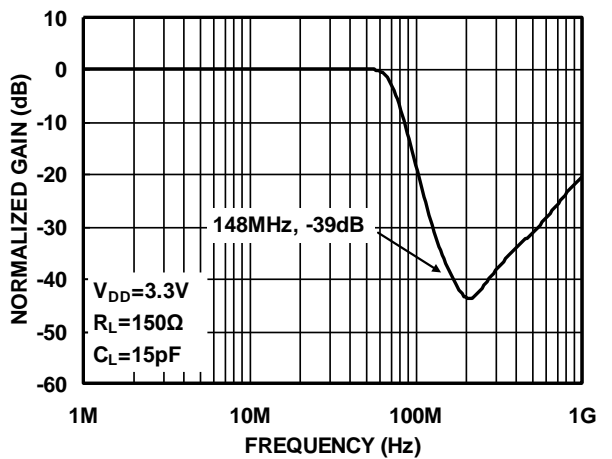

Figure8. Stop Band Attenuation

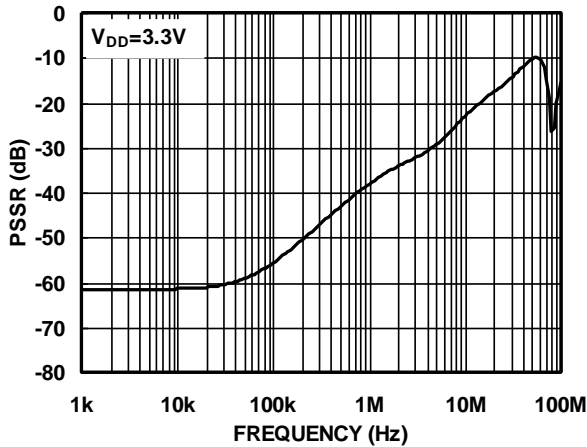

Figure9. PSRR Vs. Frequency

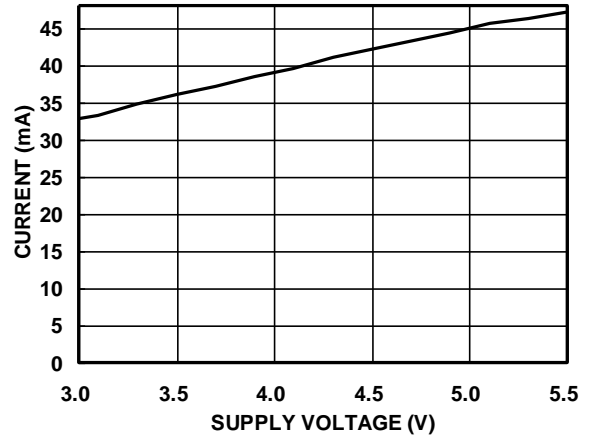

Figure10. Current Vs. Supply Voltage

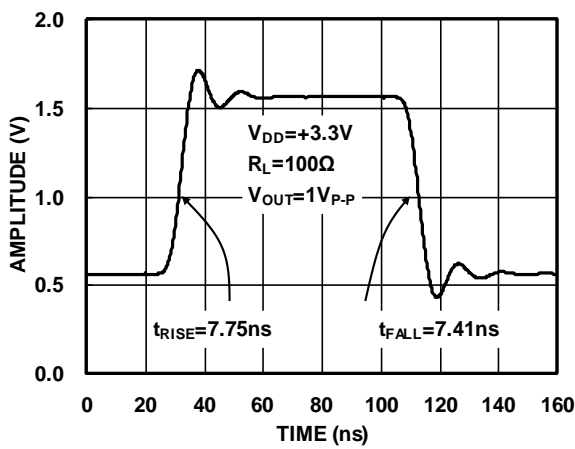

Figure11. Large-Signal Pulse Response Vs. Time

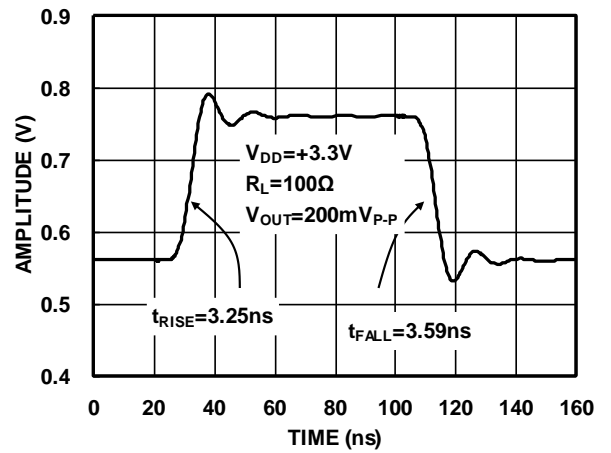

Figure12. Small-Signal Pulse Response Vs. Time

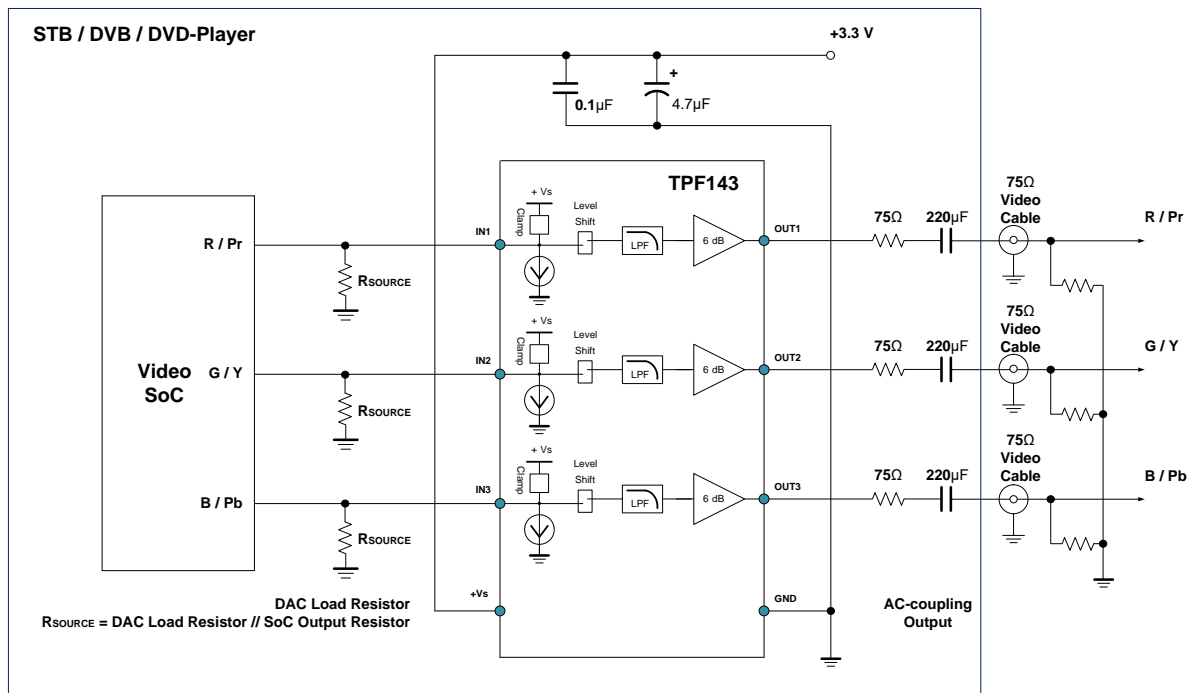

Figure13. Reference Design

Application Information

The TPF143 is targeted for systems that require three high-definition (HD) video outputs. Although it can be used for numerous other applications, the needs and requirements of the video signal are the most important design parameters of the TPF143. The TPF143 incorporates many features not typically found in integrated video parts while consuming very low power.

Internal Sync Clamp

The typical embedded video DAC operates from a ground referenced single supply. This becomes an issue because the lower level of the sync pulse output may be at a 0V reference level to some positive level. The problem is presenting a 0V input to most single supply driven amplifiers will saturate the output stage of the amplifier resulting in a clipped sync tip and degrading the video image. A larger positive reference may offset the input above its positive range.

The TPF143 features an internal sync clamp and offset function to level shift the entire video signal to the best level before it reaches the input of the amplifier stage. These features are also helpful to avoid saturation of the output stage of the amplifier by setting the signal closer to the best voltage range.

The simplified block diagram of the TPF143 in Figure-1. The AC coupled video sync signal is pulled negative by a current source at the input of the comparator amplifier. When the sync tip goes below the comparator threshold the output comparator is driven negative, The PMOS device turns on clamping sync tip to near ground level. The network triggers on the sync tip of video signal.

Droop Voltage and DC Restoration

Selection of the input AC-coupling capacitance is based on the system requirements. A typical sync tip width of a 64 μ s NTSC line is 4 μ s during which clamp circuit restores its DC level. In the remaining 60 μ s period, the voltage droops because of a small constant 2.0 μ A sinking current. If the AC-coupling capacitance is 0.1 μ F, the maximum droop voltage is

about 1mV which is restored by the clamp circuit. The maximum pull-up current of the clamp circuit is 1.7mA. For a 4 μ s sync tip width and 0.1 μ F capacitor, the maximum restoration voltage is about 80mV.

The line droop voltage will increase if a smaller AC-coupling capacitance is used. For the same reason, if larger capacitance is used the line droop voltage will decrease. Table 1 is droop voltage and maximum restoration voltage of the clamp for typical capacitance.

Table 1. Maximum restoration voltage and droop voltage of Y signals for different capacitance

CAP VALUE (nF)	DROOP IN 60 μ s (mV)	CHARGE IN 4 μ s (mV)
100	1.2	68
1,000	0.12	6.8

Low Pass Filter--Sallen Key

The Sallen Key is a classic low pass configuration. This provides a very stable low pass function, and in the case of the TPF143, the six-pole roll-off at around 72MHz. The six-pole function is accomplished with an RC low pass network placed in series with and before the Sallen Key.

Output Couple

TPF143 output could support both "AC Couple" and "DC Couple", if use "AC Couple", this capacitor is typically between 220- μ F and 1000- μ F, although 470- μ F is common. This value of this capacitor must be this large to minimize the line tilt (droop) and/or field tilt associated with ac-coupling as described previously in this document.

The TPF143 internal sync clamp makes it possible to DC couple the output to a video load, eliminating the need for any AC coupling capacitors, thereby saving board space and additional expense for capacitors. This makes the TPF143 extremely attractive for portable video applications. Additionally, this solution completely eliminates the issue of field tilt in the lower frequency. The trade off is greater demand of supply current. Typical load current for AC coupled is around 1mA, compared to typical 6.6mA used when DC

coupling.

Output Drive Capability and Power Dissipation

With the high output drive capability of the TPF143, it is possible to exceed the +125°C absolute maximum junction temperature under certain load current conditions. Therefore, it is important to calculate the maximum junction temperature for an application to determine if load conditions or package types need to be modified to assure operation of the amplifier in a safe operating area. The maximum power dissipation allowed in a package is determined according to Equation:

$$PD_{MAX} = \frac{T_{JMAX} - T_{AMAX}}{\theta_{JA}}$$

Where:

T_{JMAX} = Maximum junction temperature

T_{AMAX} = Maximum ambient temperature

θ_{JA} = Thermal resistance of the package

The maximum power dissipation actually produced by an IC is the total quiescent supply current times the total power supply voltage, plus the power in the IC due to the load, or: for sourcing:

$$PD_{MAX} = V_s \times I_{SMAX} + (V_s - V_{OUT}) \times \frac{V_{OUT}}{R_L}$$

Where:

V_s = Supply voltage

I_{SMAX} = Maximum quiescent supply current

V_{OUT} = Maximum output voltage of the application

R_{LOAD} = Load resistance tied to ground

By setting the two PD_{MAX} equations equal to each other, we can solve the output current and R_{LOAD} to avoid the device overheat.

Power Supply Bypassing Printed Circuit Board Layout

As with any modern operational amplifier, a good printed circuit board layout is necessary for optimum performance. Lead lengths should be as short as possible. The power supply pin must be well bypassed to reduce the risk of oscillation. For normal single supply operation, a single 4.7µF tantalum capacitor in parallel with a 0.1µF ceramic capacitor from VS+ to GND will suffice.

VIDEO FILTER DRIVER SELECTION GUIDE

P/N	Product Description	Channel	-3dB Bandwidth	Package
TPF110	Low power, enable function and	1-SD	9MHz	SC70-5
/TPF110L	SAG correction, 1 channel 6 th order 9MHz			SOT23-6
TPF113	Low power 3 channel, 6th-order 9MHz SD video filter	3-SD	9MHz	SO-8
TPF114	Low power 4 channel, 6th-order 9MHz SD video filter	4-SD	9MHz	MSOP-10 TSSOP-14
TPF116	Low power 4 channel, 6th-order 9MHz SD video filter for CVBS, SVIDEO	6-SD	9MHz	TSSOP-14
TPF123	3 channel 6th-order 13.5MHz, 960H/720H-CVBS video filter or Y'Pb'Pr 480P/576P video filter	3-ED	13.5MHz	SO-8
TPF133	Low power 3 channel, 6th-order 36MHz HD video filter	3-HD	36MHz	SO-8
TPF134	Low power 3 channel, 6th-order 36MHz HD video filter and 1 channel	1-SD& 3-SD	9MHz 36MHz	MSOP-10 TSSOP-14

TPF143

Low Power, 3-channel High-Definition Video Filter Driver

	SD video filter			
TPF136	Low power 3 channel, 6th-order 36MHz HD video filter and 3 channel SD video filter	3-SD& 3-HD	9MHz 36MHz	TSSOP-20
TPF143	Low power 3 channel, 6th-order 72MHz Full HD video filter	3-FHD	72MHz	SO-8
TPF144	Low power 3 channel, 6th-order 72MHz Full HD video filter and 1 channel SD video filter	1-SD& 3-FHD	9MHz 72MHz	MSOP-10 TSSOP-14
TPF146	Low power 3 channel, 6th-order 72MHz Full HD video filter and 3 channel SD video filter	3-SD& 3-FHD	9MHz 72MHz	TSSOP-20
TPF153	Low power 3 channel, 6th-order 220MHz Full HD video filter	3-CH	220MHz	SO-8

Package Outline Dimensions

SOIC-8

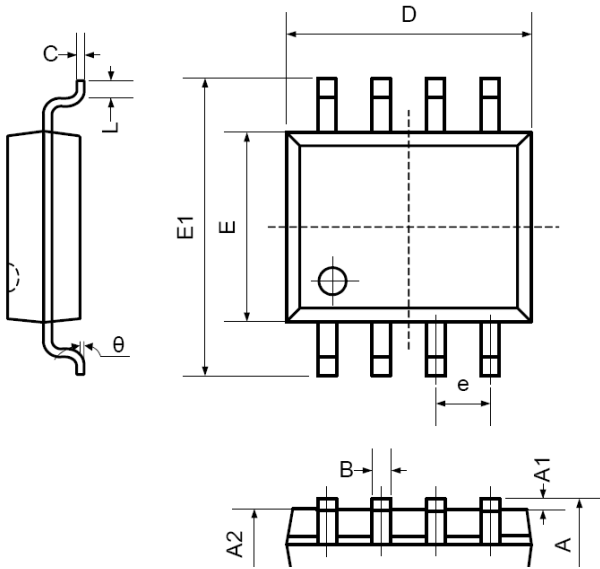

Symbol	Dimensions In Millimeters		Dimensions In Inches	
	Min	Max	Min	Max
A	1.350	1.750	0.053	0.069
A1	0.100	0.250	0.004	0.010
A2	1.350	1.550	0.053	0.061
B	0.330	0.510	0.013	0.020
C	0.190	0.250	0.007	0.010
D	4.780	5.000	0.188	0.197
E	3.800	4.000	0.150	0.157
E1	5.800	6.300	0.228	0.248
e	1.270TYP		0.050TYP	
L1	0.400	1.270	0.016	0.050
θ	0°	8°	0°	8°

IMPORTANT NOTICE AND DISCLAIMER

Copyright© 3PEAK 2012-2023. All rights reserved.

Trademarks. Any of the 思瑞浦 or 3PEAK trade names, trademarks, graphic marks, and domain names contained in this document /material are the property of 3PEAK. You may NOT reproduce, modify, publish, transmit or distribute any Trademark without the prior written consent of 3PEAK.

Performance Information. Performance tests or performance range contained in this document/material are either results of design simulation or actual tests conducted under designated testing environment. Any variation in testing environment or simulation environment, including but not limited to testing method, testing process or testing temperature, may affect actual performance of the product.

Disclaimer. 3PEAK provides technical and reliability data (including data sheets), design resources (including reference designs), application or other design recommendations, networking tools, security information and other resources "As Is". 3PEAK makes no warranty as to the absence of defects, and makes no warranties of any kind, express or implied, including without limitation, implied warranties as to merchantability, fitness for a particular purpose or non-infringement of any third-party's intellectual property rights. Unless otherwise specified in writing, products supplied by 3PEAK are not designed to be used in any life-threatening scenarios, including critical medical applications, automotive safety-critical systems, aviation, aerospace, or any situations where failure could result in bodily harm, loss of life, or significant property damage. 3PEAK disclaims all liability for any such unauthorized use.