

## 5-V, 10-MHz, Zero-Crossover, Low Input Bias Current, RRIO, High Precision Operational Amplifier

### Features

- Supply Voltage: 2.2 V to 5.5 V
- Precision with Zero-crossover Distortion
- Low Offset Voltage:  $\pm 0.5 \mu\text{V}$  Maximum
- Low Offset Voltage Drift:
  - $\pm 0.5 \mu\text{V}/^\circ\text{C}$  Typical
  - $\pm 1 \mu\text{V}/^\circ\text{C}$  Maximum
- Ultra Low Input Bias Current:
  - $\pm 50 \text{ fA}$  Typical
  - $\pm 1 \text{ pA}$  Maximum
- Rail-to-Rail Input and Output
- Gain-Bandwidth Product: 10 MHz
- Slew Rate: 6 V/ $\mu\text{s}$
- Operation Temperature Range:  $-40^\circ\text{C}$  to  $125^\circ\text{C}$
- Excellent input EMI immunity
- Continuous Time Amplifier with Trim Technology

### Applications

- Instrumentation
- Sensor Interface
- Optical Module
- Industrial Control
- Audio

### Optical Module Applications

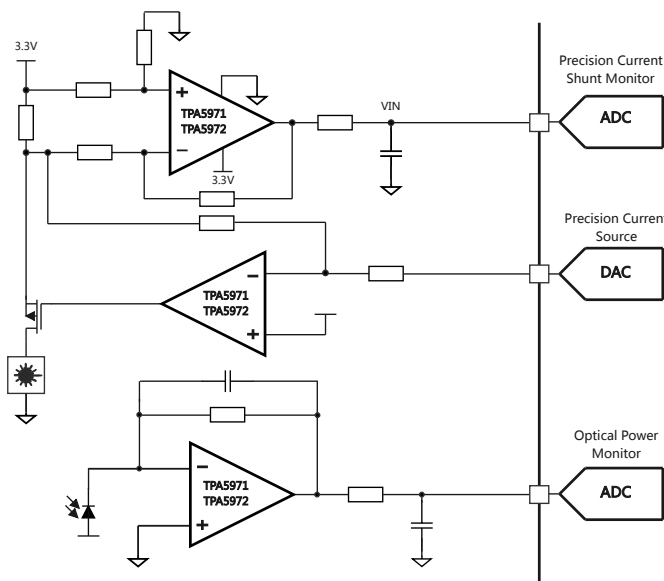

### Description

The TPA597x family (TPA5971, TPA5972) of operational amplifiers delivers exceptional DC precision and AC performance for high-fidelity signal chains. Features include ultra-low offset voltage, low drift, femtoampere input bias current, and rail-to-rail I/O. AC performance is optimized for low noise and fast settling, enabling high-speed data acquisition. These amplifiers are ideal for driving ADCs or buffering DACs in instrumentation.

The TPA597x is a continuous time amplifier with trim technology achieves that ultra-low offset and drift without chopping or auto-zero, preserving low-frequency noise. In addition, the zero-crossover input stage eliminates the distortion inherent in traditional complementary input pairs, providing consistent low offset, high linearity, and stable CMRR across the entire common-mode range. This combination makes the TPA597x excellent for sensor interfaces, photodiode transimpedance stages, optical modules, and medical instruments demanding both dc accuracy and ac speed.

TPA5971 is available in a 5-ball WLCSP package and a SOT23-5 package. TPA5972 is available in 8-lead MSOP and 8-ball WLCSP packages. All of them are specified over the  $-40^\circ\text{C}$  to  $+125^\circ\text{C}$  extended industrial temperature range.

### Device Table

Device	Package	Body Size
TPA5971-S5TR	SOT23-5	2.9 mm × 1.6 mm
TPA5971-WLPR	WLCSP	1.4 mm × 0.8 mm
TPA5972-SO1R	SOP8	4.9 mm × 3.9 mm
TPA5972-VS1R	MSOP8	3.0 mm × 3.0 mm
TPA5972-WLPR	WLCSP	1.7 mm × 1.4 mm

---

**5-V, 10-MHz, Zero-Crossover, Low Input Bias Current, RRIO, High Precision Operational Amplifier****Table of Contents**

<b>Features</b> .....	<b>1</b>
<b>Applications</b> .....	<b>1</b>
<b>Optical Module Applications</b> .....	<b>1</b>
<b>Description</b> .....	<b>1</b>
<b>Device Table</b> .....	<b>1</b>
<b>Revision History</b> .....	<b>3</b>
<b>Pin Configuration and Functions</b> .....	<b>4</b>
<b>Specifications</b> .....	<b>7</b>
Absolute Maximum Ratings <sup>(1)</sup> .....	7
ESD, Electrostatic Discharge Protection.....	7
Recommended Operating Conditions.....	7
Thermal Information.....	8
Electrical Characteristics.....	9
Typical Performance Characteristics.....	11
<b>Detailed Description</b> .....	<b>14</b>
Overview.....	14
Functional Block Diagram.....	14
Feature Description.....	14
<b>Application and Implementation</b> .....	<b>15</b>
Application Information .....	15
<b>Tape and Reel Information</b> .....	<b>17</b>
<b>Package Outline Dimensions</b> .....	<b>19</b>
SOT23-5.....	19
WLCSP.....	20
SOP8.....	21
MSOP8.....	22
WLCSP.....	23
<b>Order Information</b> .....	<b>24</b>
<b>IMPORTANT NOTICE AND DISCLAIMER</b> .....	<b>25</b>

---

**5-V, 10-MHz, Zero-Crossover, Low Input Bias Current, RRIO, High  
Precision Operational Amplifier****Revision History**

Date	Revision	Notes
2026-03-30	Rev.A.0	Initial version.

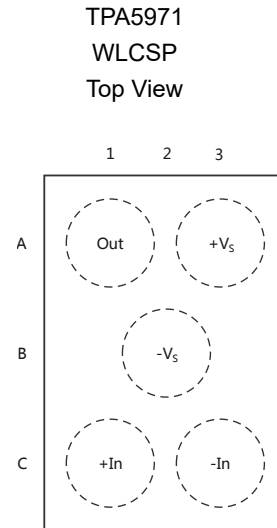
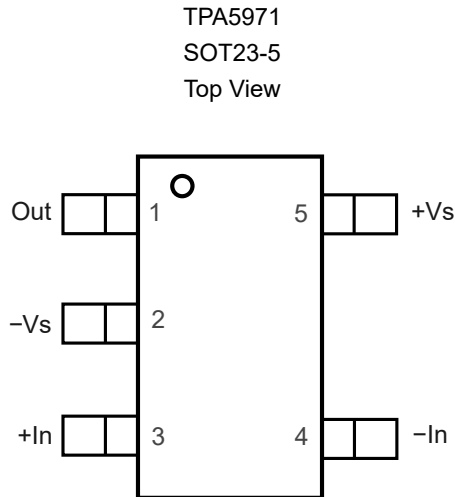
**5-V, 10-MHz, Zero-Crossover, Low Input Bias Current, RRIO, High Precision Operational Amplifier**
**Pin Configuration and Functions**

**Table 1. Pin Functions: TPA5971**

Pin No.		Name	I/O	Description
SOT23-5	WLCSP			
1	A1	Out	O	Output
2	B2	-Vs		Negative power supply
3	C1	+In	I	Non-inverting input
4	C3	-In	I	Inverting input
5	A3	+Vs		Positive power supply

5-V, 10-MHz, Zero-Crossover, Low Input Bias Current, RRIO, High Precision Operational Amplifier

TPA5972  
WLCSP  
Top View

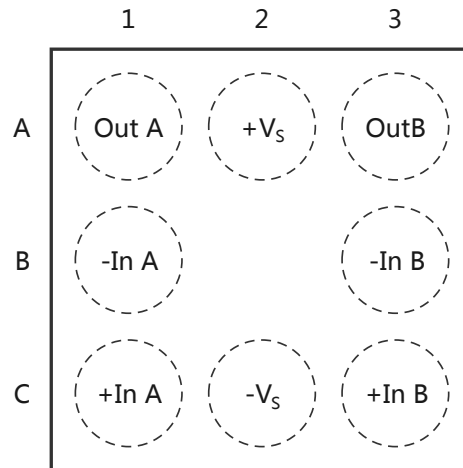
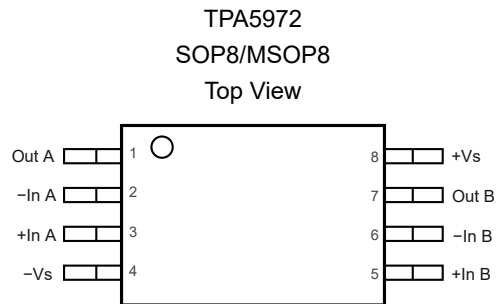

Table 2. Pin Functions: TPA5972

Pin No.	Name	I/O	Description
A1	Out A	O	Output
B1	-In A	I	Inverting input
C1	+In A	I	Non-inverting input
C2	-Vs		Negative power supply
C3	+In B	I	Non-inverting input
B3	-In B	I	Inverting input
A3	Out B	O	Output
A2	+Vs		Positive power supply

**5-V, 10-MHz, Zero-Crossover, Low Input Bias Current, RRIO, High Precision Operational Amplifier**

**Table 3. Pin Functions: TPA5972**

Pin No.	Name	I/O	Description
1	Out A	O	Output
2	-In A	I	Inverting input
3	+In A	I	Non-inverting input
4	-Vs		Negative power supply
5	+In B	I	Non-inverting input
6	-In B	I	Inverting input
7	Out B	O	Output
8	+Vs		Positive power supply

## 5-V, 10-MHz, Zero-Crossover, Low Input Bias Current, RRIO, High Precision Operational Amplifier

### Specifications

#### Absolute Maximum Ratings <sup>(1)</sup>

Over operating ambient temperature (unless otherwise noted) <sup>(1)</sup>

Parameter		Min	Max	Unit
	Supply Voltage, (+V <sub>S</sub> ) – (–V <sub>S</sub> )		6	V
	Input Voltage	(–V <sub>S</sub> ) – 0.3	(+V <sub>S</sub> ) + 0.3	V
	Differential Input Voltage	(–V <sub>S</sub> ) – (+V <sub>S</sub> )	(+V <sub>S</sub> ) – (–V <sub>S</sub> )	V
	Input Current: +I <sub>N</sub> , –I <sub>N</sub> <sup>(2)</sup>	–10	10	mA
	Output Voltage	(–V <sub>S</sub> ) – 0.1	(+V <sub>S</sub> ) + 0.1	V
	Output Short-Circuit Duration		Infinite	
T <sub>J</sub>	Maximum Operating Junction Temperature		150	°C
T <sub>A</sub>	Operating Temperature Range	–40	125	°C
T <sub>STG</sub>	Storage Temperature Range	–65	150	°C
T <sub>L</sub>	Lead Temperature (Soldering, 10 sec)		260	°C

(1) Stresses beyond those listed under Absolute Maximum Ratings may cause permanent damage to the device. Exposure to any Absolute Maximum Rating condition for extended periods may affect device reliability and lifetime.

(2) A heat sink may be required to keep the junction temperature below the absolute maximum. This depends on the power supply voltage and how many amplifiers are shorted. Thermal resistance varies with the amount of PC board metal connected to the package. The specified values are for short traces connected to the leads.

#### ESD, Electrostatic Discharge Protection

Symbol	Parameter	Condition	Minimum Level	Unit
HBM	Human Body Model ESD	ANSI/ESDA/JEDEC JS-001 <sup>(1)</sup>	5	kV
CDM	Charged Device Model ESD	ANSI/ESDA/JEDEC JS-002 <sup>(2)</sup>	1.5	kV
LU	Latch Up	JESD 78, 25°C	600	mA
		JESD 78, 125°C	400	mA

(1) JEDEC document JEP155 states that 500-V HBM allows safe manufacturing with a standard ESD control process.

(2) JEDEC document JEP157 states that 250-V CDM allows safe manufacturing with a standard ESD control process.

#### Recommended Operating Conditions

Parameter		Min	Typ	Max	Unit
V <sub>S</sub>	Supply Voltage, (+V <sub>S</sub> ) – (–V <sub>S</sub> )	2.2		5.5	V
T <sub>A</sub>	Operating Temperature Range	–40		125	°C

---

**5-V, 10-MHz, Zero-Crossover, Low Input Bias Current, RRIO, High Precision Operational Amplifier****Thermal Information**

Package Type	$\theta_{JA}$	$\theta_{JC}$	Unit
SOT23-5	250	81	°C/W
WLCSP (TPA5971)	243	48	°C/W
SOP8	158	43	°C/W
MSOP	163	61	°C/W
WLCSP (TPA5972)	200	27	°C/W

## 5-V, 10-MHz, Zero-Crossover, Low Input Bias Current, RRIO, High Precision Operational Amplifier

### Electrical Characteristics

All test conditions:  $V_S = 5\text{ V}$ ,  $T_A = 25^\circ\text{C}$ ,  $R_L = 10\text{ k}\Omega$ , unless otherwise noted.

Parameter		Conditions	Min	Typ	Max	Unit
<b>Power Supply</b>						
$V_S$	Supply Voltage Range		2.2		5.5	V
$I_Q$	Quiescent Current per Amplifier	$V_S = 5\text{ V}$		1.8	2.6	mA
		$V_S = 5\text{ V}$ , $T_A = -40^\circ\text{C}$ to $125^\circ\text{C}$			3.2	mA
PSRR	Power Supply Rejection Ratio	$V_S = 2.2\text{ V}$ to $5.5\text{ V}$	96	120		dB
		$V_S = 2.2\text{ V}$ to $5.5\text{ V}$ , $T_A = -40^\circ\text{C}$ to $125^\circ\text{C}$	90			dB
<b>Input Characteristics</b>						
$V_{OS}$	Input Offset Voltage	$V_S = 5\text{ V}$ , $V_{CM} = 0\text{ V}$	-50		50	$\mu\text{V}$
$V_{OS}$	Input Offset Voltage	$V_S = 5\text{ V}$ , $V_{CM} = 0\text{ V}$ , $T_A = -40^\circ\text{C}$ to $125^\circ\text{C}$	-150		150	$\mu\text{V}$
$V_{OS\ TC}$	Input Offset Voltage Drift	$T_A = -40^\circ\text{C}$ to $125^\circ\text{C}$	-1	$\pm 0.5$	1	$\mu\text{V}/^\circ\text{C}$
$I_B$	Input Bias Current <sup>(1)</sup>	$V_S = 5\text{ V}$ , $V_{CM} = 0\text{ V}$ to $5\text{ V}$	-1	0.05	1	pA
$I_B$	Input Bias Current <sup>(1)</sup>	$V_S = 5\text{ V}$ , $V_{CM} = 0\text{ V}$ to $5\text{ V}$ , $T_A = -40^\circ\text{C}$ to $85^\circ\text{C}$	-1		1	pA
$I_B$	Input Bias Current <sup>(1)</sup>	$V_S = 5\text{ V}$ , $V_{CM} = 0\text{ V}$ to $5\text{ V}$ , $T_A = -40^\circ\text{C}$ to $125^\circ\text{C}$	-30		30	pA
$I_{OS}$	Input Offset Current <sup>(1)</sup>	$V_S = 5\text{ V}$ , $V_{CM} = 0\text{ V}$ to $5\text{ V}$	-1	0.05	1	pA
$I_{OS}$	Input Offset Current <sup>(1)</sup>	$V_S = 5\text{ V}$ , $V_{CM} = 0\text{ V}$ to $5\text{ V}$ , $T_A = -40^\circ\text{C}$ to $85^\circ\text{C}$	-1		1	pA
$I_{OS}$	Input Offset Current <sup>(1)</sup>	$V_S = 5\text{ V}$ , $V_{CM} = 0\text{ V}$ to $5\text{ V}$ , $T_A = -40^\circ\text{C}$ to $125^\circ\text{C}$	-10		10	pA
$C_{IN}$	Input Capacitance	Differential Mode		4		pF
$C_{IN}$	Input Capacitance	Common Mode		2		pF
$A_v$	Open-loop Voltage Gain		100	110		dB
CMRR	Common Mode Rejection Ratio	$V_S = 5\text{ V}$ , $V_{CM} = -0.1\text{ V}$ to $5.1\text{ V}$	100	125		dB
CMRR	Common Mode Rejection Ratio	$V_S = 5\text{ V}$ , $V_{CM} = -0.1\text{ V}$ to $5.1\text{ V}$ , $T_A = -40^\circ\text{C}$ to $125^\circ\text{C}$	90			dB
$V_{CMR}$	Common-mode Input Voltage Range		(V-) - 0.1		(V+) +0.1	V
<b>Output Characteristics</b>						
	Output Swing from Positive Rail	$R_{LOAD} = 10\text{ k}\Omega$ to $V_S/2$		8	10	mV
		$T_A = -40^\circ\text{C}$ to $125^\circ\text{C}$			15	mV
		$R_{LOAD} = 2\text{ k}\Omega$ to $V_S/2$		38	45	mV
		$T_A = -40^\circ\text{C}$ to $125^\circ\text{C}$			60	mV

**5-V, 10-MHz, Zero-Crossover, Low Input Bias Current, RRIO, High Precision Operational Amplifier**

Parameter		Conditions	Min	Typ	Max	Unit
	Output Swing from Negative Rail	$R_{LOAD} = 10\text{ k}\Omega$ to $V_S/2$		7	10	mV
		$T_A = -40\text{ }^\circ\text{C}$ to $125\text{ }^\circ\text{C}$			15	mV
		$R_{LOAD} = 2\text{ k}\Omega$ to $V_S/2$		32	38	mV
		$T_A = -40\text{ }^\circ\text{C}$ to $125\text{ }^\circ\text{C}$			60	mV
I <sub>sc</sub>	Output Short-Circuit Current	Source		55		mA
		Sink		55		mA
<b>AC Specifications</b>						
GBW	Gain-Bandwidth Product			10		MHz
SR	Slew Rate	$G = 1$ , 1 V step		6		V/ $\mu$ s
T <sub>or</sub>	Overload Recovery Time			400		ns
t <sub>s</sub>	Settling Time 0.1%	$G = 1$ , 4 V step		500		ns
t <sub>s</sub>	Settling Time 0.01%	$G = 1$ , 4 V step		750		ns
PM	Phase Margin			50		°
<b>Noise Performance</b>						
E <sub>N</sub>	Input Voltage Noise	$f = 0.1\text{ Hz}$ to $10\text{ Hz}$		7.3		$\mu$ V <sub>PP</sub>
e <sub>N</sub>	Input Voltage Noise Density	$f = 1\text{ kHz}$		12.5		nV/ $\sqrt{\text{Hz}}$
		$f = 10\text{ kHz}$		8.6		nV/ $\sqrt{\text{Hz}}$
		$f = 100\text{ kHz}$		7.8		nV/ $\sqrt{\text{Hz}}$
THD+N	Total Harmonic Distortion and Noise	$f = 1\text{ kHz}$ , $G = 1$ , $R_L = 10\text{ k}\Omega$ , $V_{OUT} = 1\text{ V}_{rms}$		0.0002		%

(1) Guaranteed by bench test and design simulation.

5-V, 10-MHz, Zero-Crossover, Low Input Bias Current, RRIO, High Precision Operational Amplifier

Typical Performance Characteristics

All test conditions:  $V_s = 5\text{ V}$ ,  $V_{CM} = 2.5\text{ V}$ ,  $R_L = 10\text{ k}\Omega$ , unless otherwise noted.

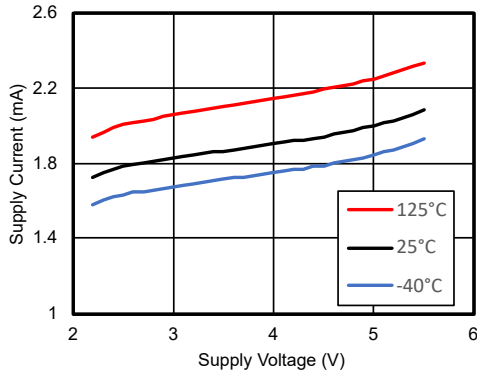

Figure 1. Quiescent Current vs. Supply Voltage

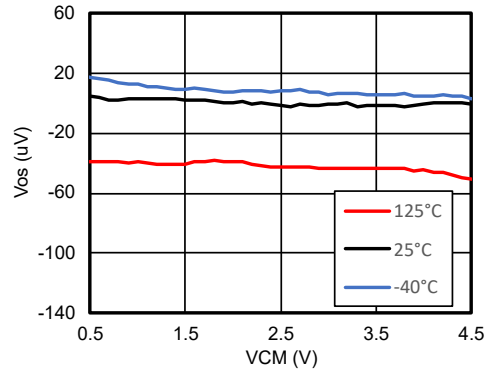

Figure 2. Offset Voltage vs. Common-Mode Voltage

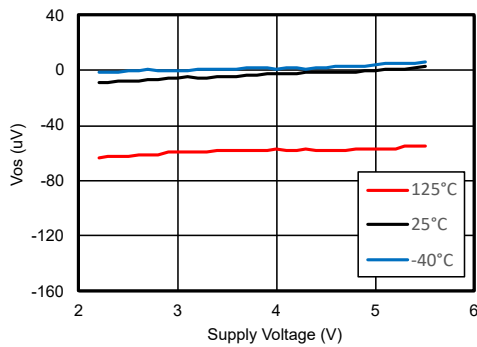

Figure 3. Offset Voltage vs. Supply Voltage

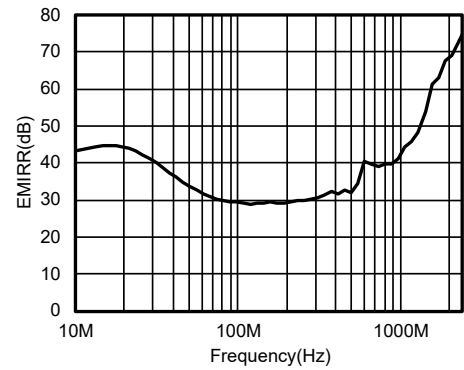

Figure 4. EMIRR vs. Frequency

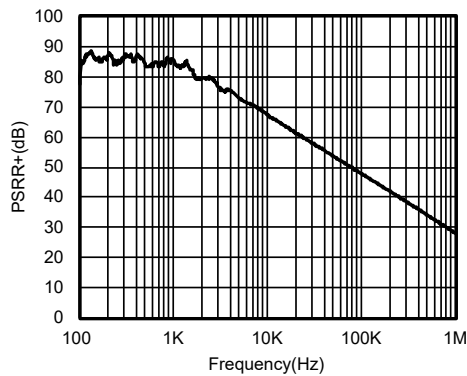

Figure 5. PSRR+ vs. Frequency

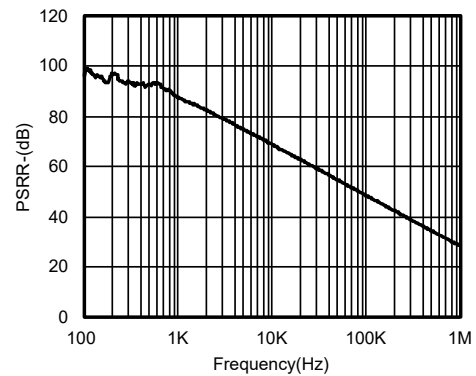

Figure 6. PSRR- vs. Frequency

5-V, 10-MHz, Zero-Crossover, Low Input Bias Current, RRIO, High Precision Operational Amplifier

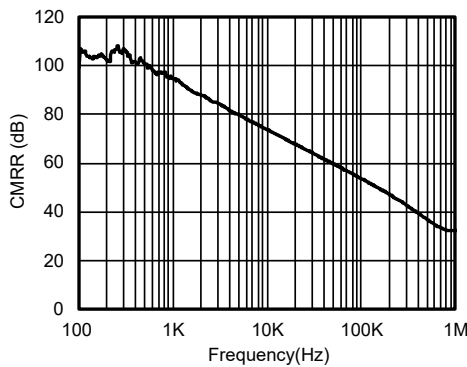

Figure 7. CMRR vs. Frequency

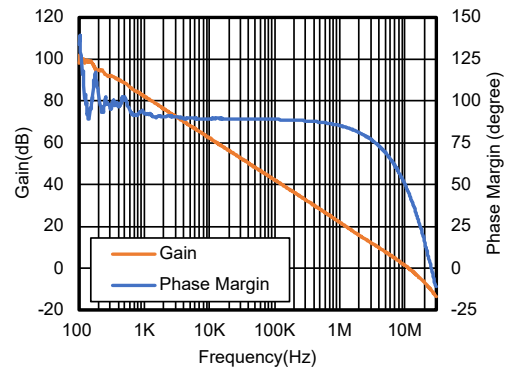

Figure 8. Open Loop Gain and Phase vs. Frequency

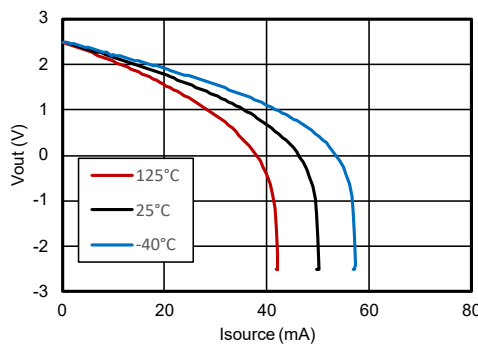

Figure 9. Output Voltage vs. Output Current, Source

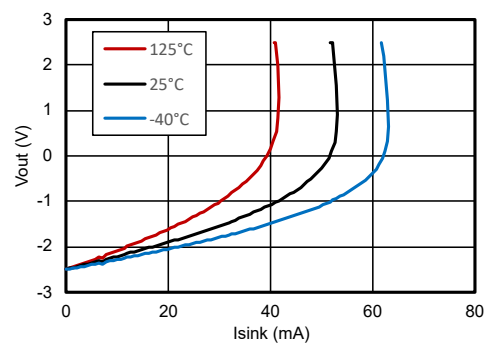

Figure 10. Output Voltage vs. Output Current, Sink

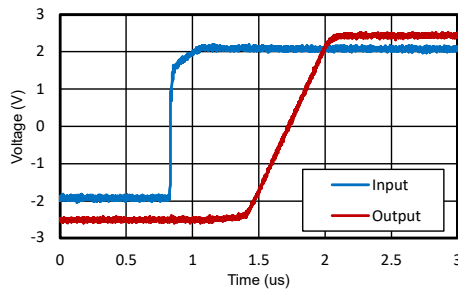

Figure 11. Positive Overload Recovery

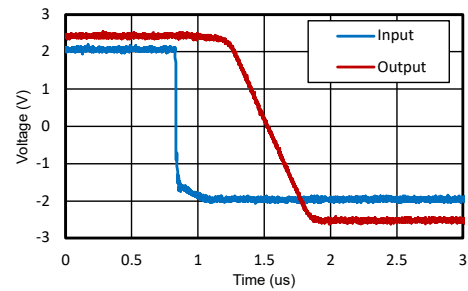

Figure 12. Negative Overload Recovery

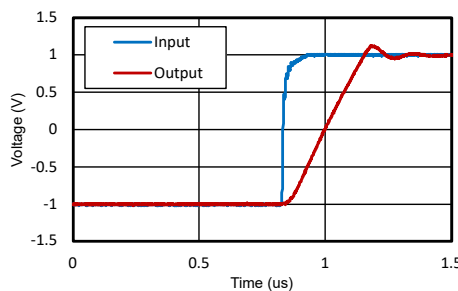

Figure 13. Slew Rate Rise

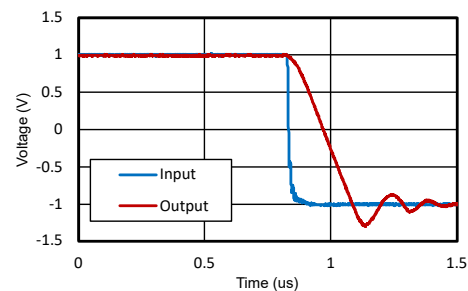
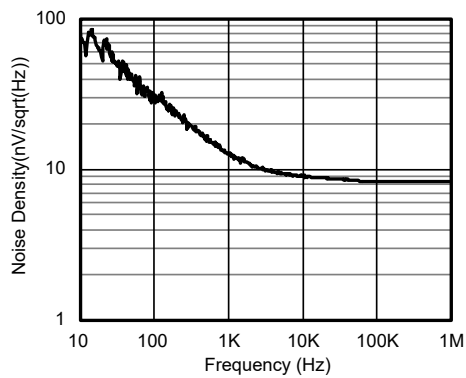
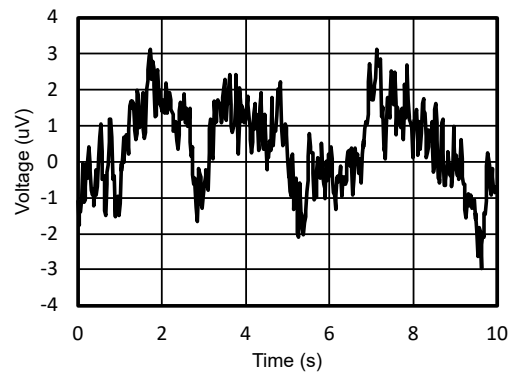

Figure 14. Slew Rate Fall

**5-V, 10-MHz, Zero-Crossover, Low Input Bias Current, RRIO, High Precision Operational Amplifier****Figure 15. Voltage Noise Spectral Density vs. Frequency****Figure 16. 0.1-Hz to 10-Hz Voltage Noise**

## 5-V, 10-MHz, Zero-Crossover, Low Input Bias Current, RRIO, High Precision Operational Amplifier

### Detailed Description

#### Overview

The TPA597x is a series of zero-crossover, rail-to-rail input and output, ultra low input bias current, high precision operational amplifiers. The series operates from 2.2 V to 5.5 V, and is unity-gain stable and designed for a wide range of general-purpose applications.

#### Functional Block Diagram

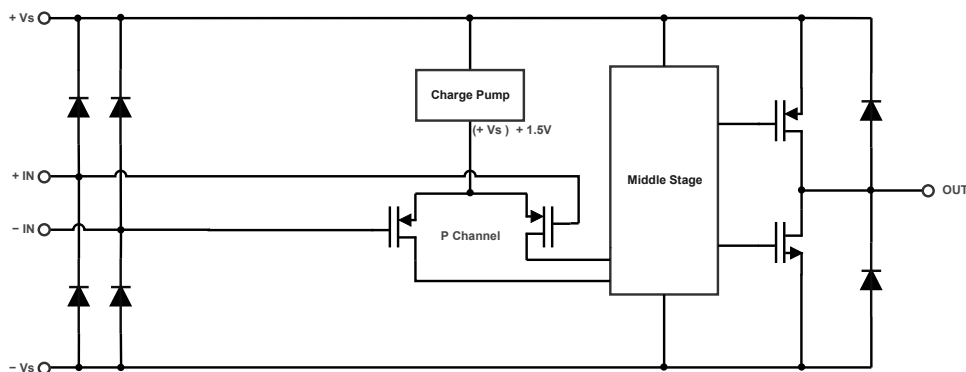

Figure 17. Functional Block Diagram

#### Feature Description

##### Operating Voltage

The TPA597x series is designed for the single-supply operation from 2.2 V to 5.5 V, or dual-supply operation from  $\pm 1.1$  V to  $\pm 2.75$  V.

##### Rail-to-Rail Input

The devices have unique zero-crossover input topology to eliminate the input offset transition region, which is brought by the complementary input stage of rail-to-rail input operational amplifiers. The input common-mode range includes both the negative and positive supplies, CMRR is excellent in all common-mode range and no input stage crossover distortion. When driving ADCs, the highly linear common-mode range of the devices assures that the signal conditional system linearity performance is not compromised.

##### Rail-to-Rail Output

The device delivers rail-to-rail output swing capability with a class-AB output stage. Different load conditions change the ability of the amplifier to swing close to the rails.

5-V, 10-MHz, Zero-Crossover, Low Input Bias Current, RRIO, High Precision Operational Amplifier

Application and Implementation

Note

Information in the following application sections is not part of the 3PEAK's component specification and 3PEAK does not warrant its accuracy or completeness. 3PEAK's customers are responsible for determining suitability of components for their purposes. Customers should validate and test their design implementation to confirm system functionality.

Application Information

Photodiode Circuits Application

Current-to-voltage (I-V) conversion is a fundamental front-end signal-conditioning technique, widely implemented in photodiode applications where the amplifier operates as a transimpedance amplifier (TIA). In this configuration, the photocurrent generated by the photodiode—connected to the inverting input node—is linearly converted into an output voltage.

Figure 18 shows a silicon photodiode biased at zero voltage, operating in the so-called photovoltaic mode. This biasing scheme effectively minimizes shot noise and dark-current drift, while also reducing the adverse effects of junction capacitance. As a result, the configuration delivers low-noise, high-linearity signal acquisition across a wide dynamic range, making it particularly suitable for precision instrumentation and metrology-grade measurement systems.

The TPA597x family is particularly well suited for such precision photodetection systems, owing to its exceptionally low input bias current, wide unity-gain bandwidth, and superior voltage and current noise spectral densities. These attributes make it an ideal choice for demanding applications including fibre-optic link monitoring, active motion sensing, and high-speed barcode scanning.

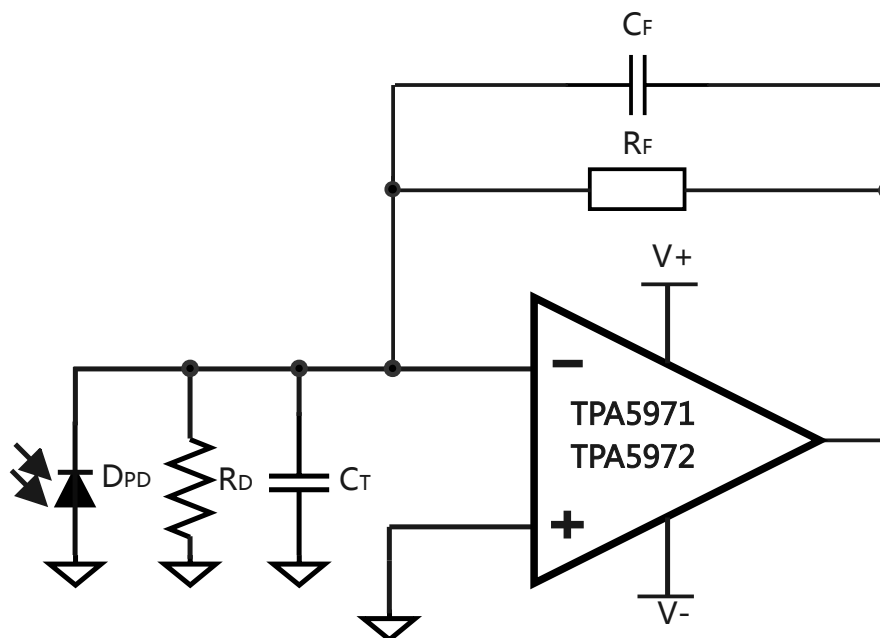

Figure 18. Transimpedance Amplifier Circuit

---

**5-V, 10-MHz, Zero-Crossover, Low Input Bias Current, RRIO, High  
Precision Operational Amplifier****Power Supply Recommendations**

Place 20- $\mu$ F bypass capacitors close to the power supply pins to reduce coupling errors from the noisy or high impedance power supplies.

5-V, 10-MHz, Zero-Crossover, Low Input Bias Current, RRIO, High Precision Operational Amplifier

Tape and Reel Information

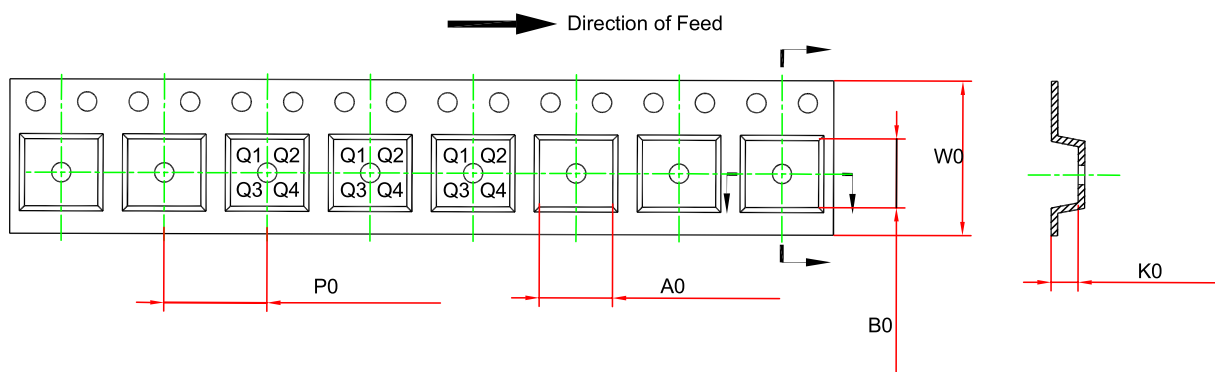
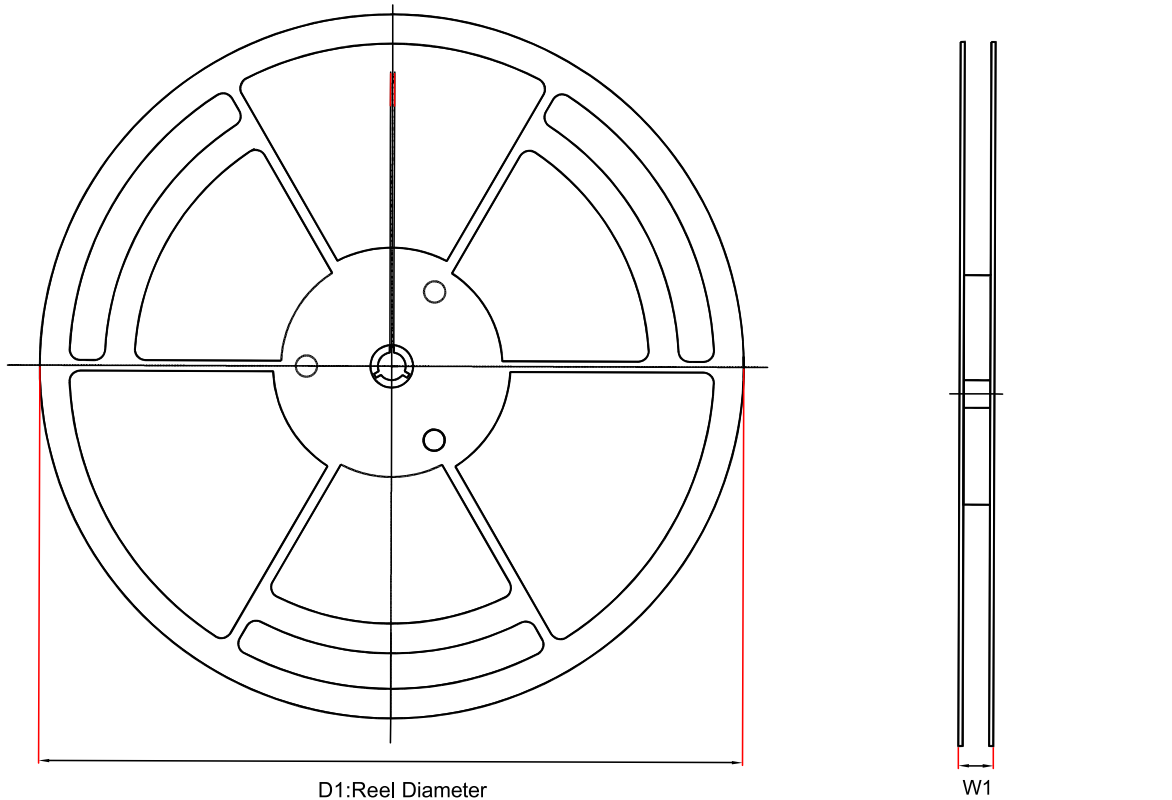

Order Number	Package	D1 (mm)	W1 (mm)	A0 (mm) <sup>(1)</sup>	B0 (mm) <sup>(1)</sup>	K0 (mm) <sup>(1)</sup>	P0 (mm)	W0 (mm)	Pin1 Quadrant
TPA5971-S5TR	SOT23-5	180.0	13.1	3.2	3.2	1.4	4.0	8.0	Q3
TPA5971-WLPR	WLCSP	179.0	12.2	1.01	1.55	0.73	4.0	8.0	Q1
TPA5972-SO1R	SOP8	330.0	17.6	6.4	5.4	2.1	8.0	12.0	Q1
TPA5972-VS1R	MSOP8	330.0	17.6	5.3	3.4	1.3	8.0	12.0	Q1

---

**5-V, 10-MHz, Zero-Crossover, Low Input Bias Current, RRIO, High Precision Operational Amplifier**

Order Number	Package	D1 (mm)	W1 (mm)	A0 (mm) <sup>(1)</sup>	B0 (mm) <sup>(1)</sup>	K0 (mm) <sup>(1)</sup>	P0 (mm)	W0 (mm)	Pin1 Quadrant
TPA5972-WLPR	WLCSP	179.0	12.2	1.6	2	0.85	4.0	8.0	Q1

(1) The value is for reference only. Contact the 3PEAK factory for more information.

5-V, 10-MHz, Zero-Crossover, Low Input Bias Current, RRIO, High Precision Operational Amplifier

Package Outline Dimensions

SOT23-5

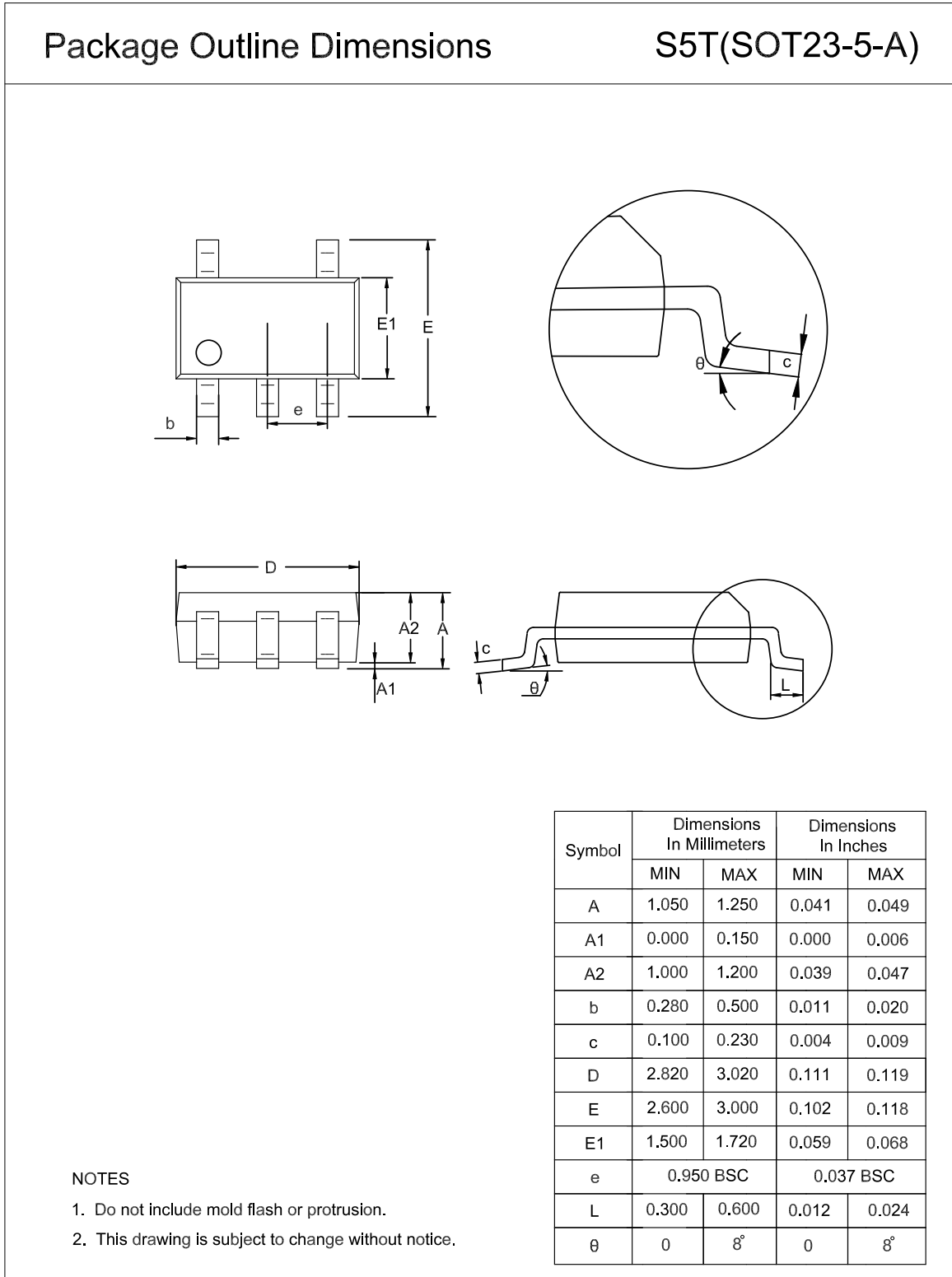

5-V, 10-MHz, Zero-Crossover, Low Input Bias Current, RRIO, High Precision Operational Amplifier

WLCSP

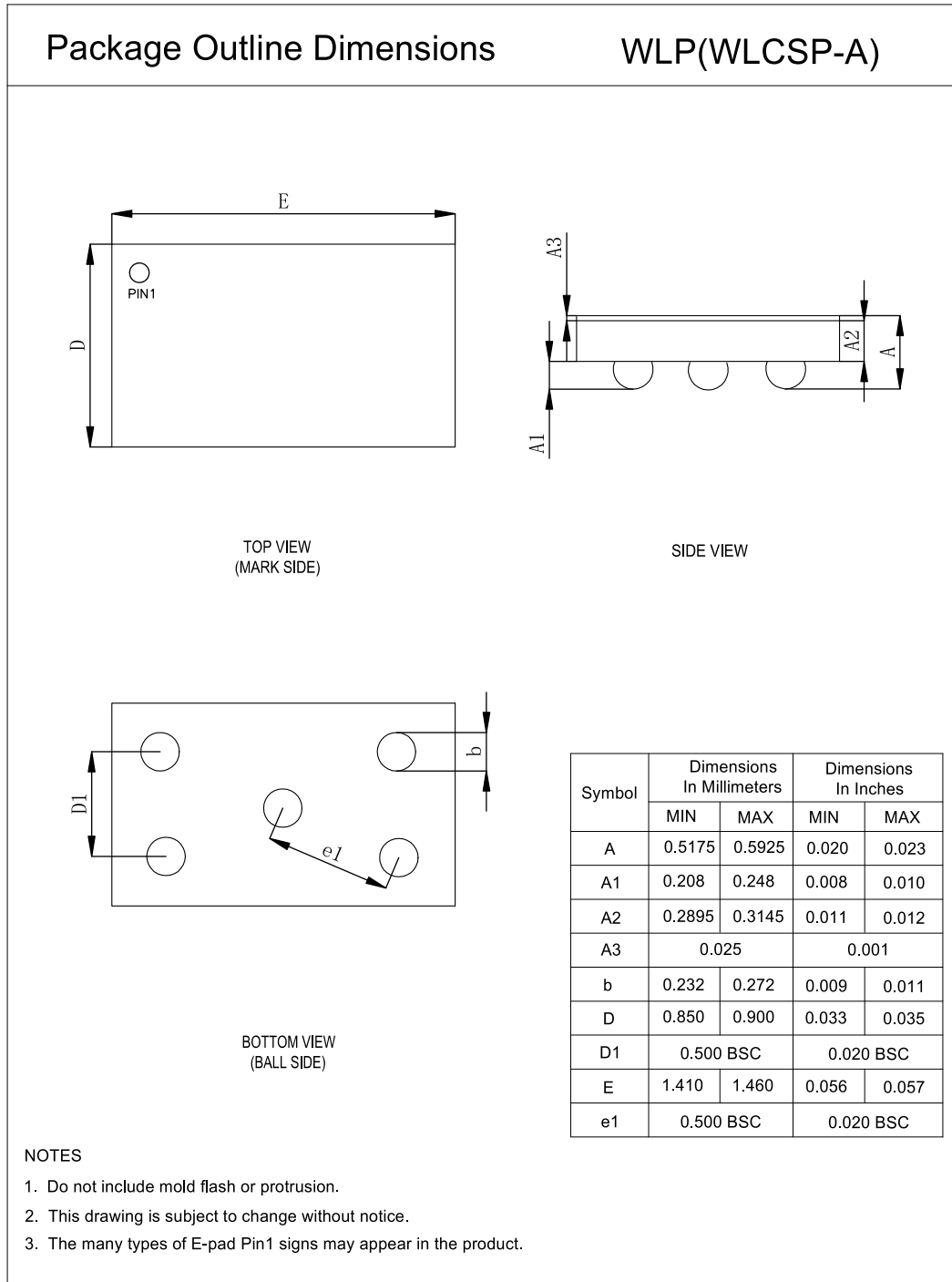

5-V, 10-MHz, Zero-Crossover, Low Input Bias Current, RRIO, High Precision Operational Amplifier

SOP8

Package Outline Dimensions

SO1(SOP-8-A)

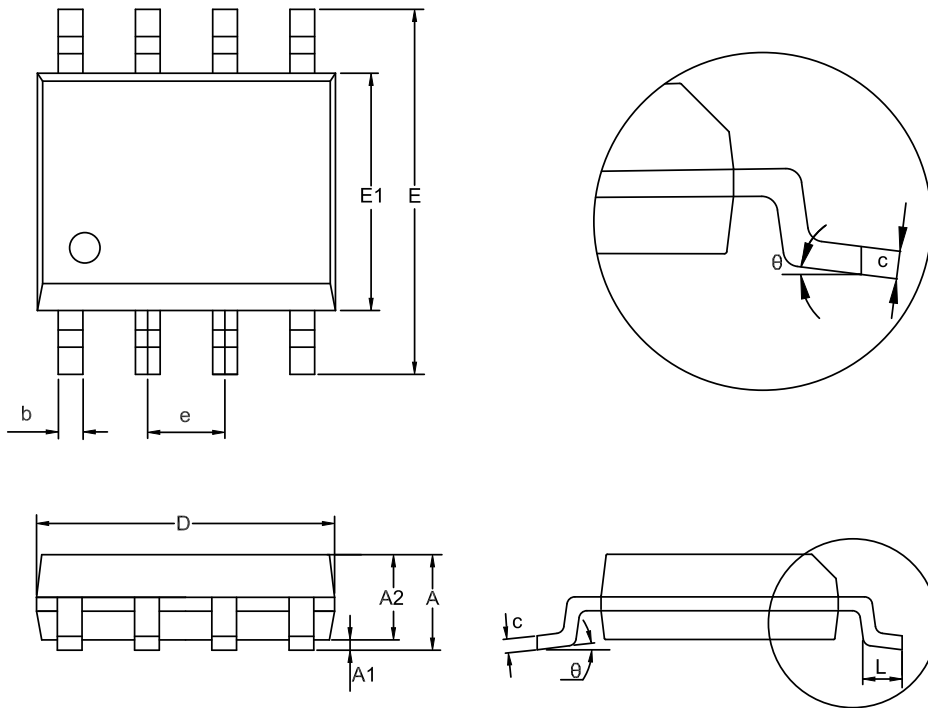

Symbol	Dimensions In Millimeters		Dimensions In Inches	
	MIN	MAX	MIN	MAX
A	1.350	1.750	0.053	0.069
A1	0.050	0.250	0.002	0.010
A2	1.250	1.550	0.049	0.061
b	0.330	0.510	0.013	0.020
c	0.170	0.250	0.007	0.010
D	4.700	5.100	0.185	0.201
E	5.800	6.200	0.228	0.244
E1	3.800	4.000	0.150	0.157
e	1.270 BSC		0.050 BSC	
L	0.400	1.000	0.016	0.039
θ	0	8°	0	8°

NOTES

1. Do not include mold flash or protrusion.
2. This drawing is subject to change without notice.

5-V, 10-MHz, Zero-Crossover, Low Input Bias Current, RRIO, High Precision Operational Amplifier

MSOP8

Package Outline Dimensions

VS1(MSOP-8-A)

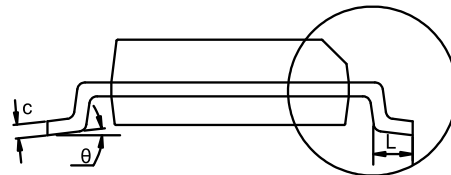
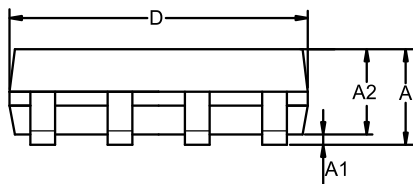
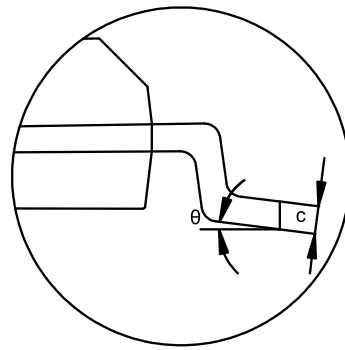
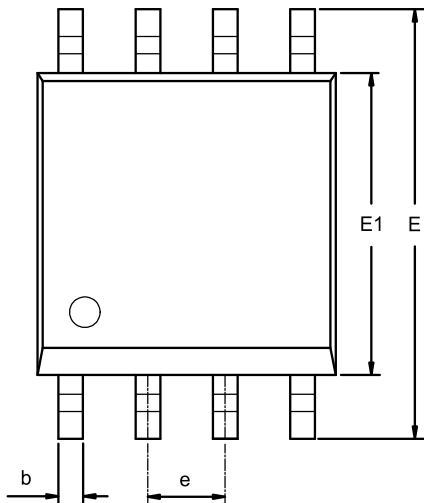

Symbol	Dimensions In Millimeters		Dimensions In Inches	
	MIN	MAX	MIN	MAX
A	0.800	1.100	0.031	0.043
A1	0.020	0.150	0.001	0.006
A2	0.750	0.950	0.030	0.037
b	0.250	0.380	0.010	0.015
c	0.090	0.230	0.004	0.009
D	2.900	3.100	0.114	0.122
E	4.700	5.100	0.185	0.201
E1	2.900	3.100	0.114	0.122
e	0.650 BSC		0.026 BSC	
L	0.400	0.800	0.016	0.031
$\theta$	0	8°	0	8°

NOTES

1. Do not include mold flash or protrusion.
2. This drawing is subject to change without notice.

5-V, 10-MHz, Zero-Crossover, Low Input Bias Current, RRIO, High Precision Operational Amplifier

WLCSP

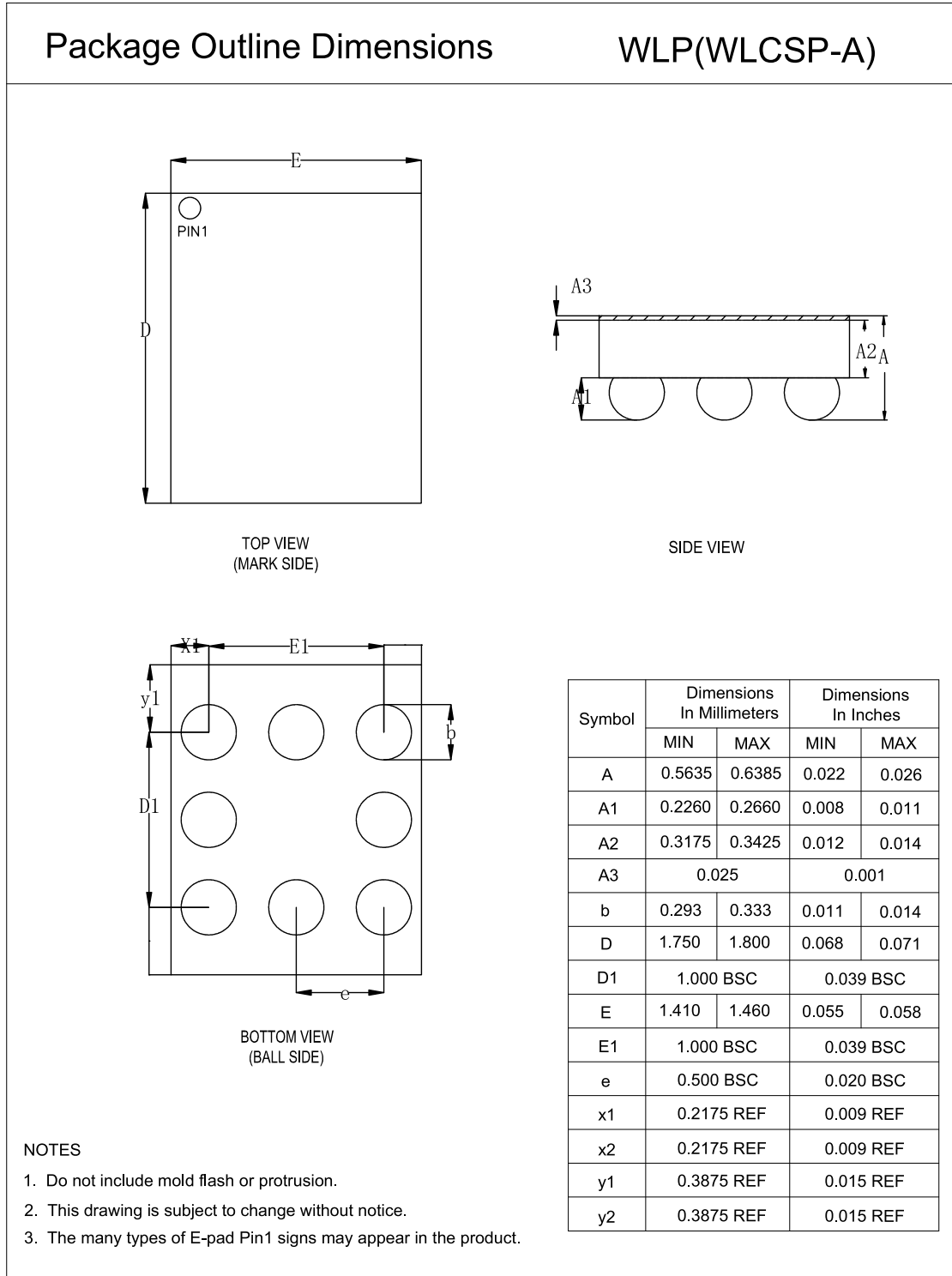

---

**5-V, 10-MHz, Zero-Crossover, Low Input Bias Current, RRIO, High Precision Operational Amplifier**

---

**Order Information**

Order Number	Operating Temperature Range	Package	Marking Information	MSL	Transport Media, Quantity	Eco Plan
TPA5971-S5TR	-40 to 125°C	SOT23-5	AAN	1	Tape and Reel, 3000	Green
TPA5971-WLPR <sup>(1)</sup>	-40 to 125°C	WLCSP	AAR	1	Tape and Reel, 3000	Green
TPA5972-SO1R	-40 to 125°C	SOP8	A5972	1	Tape and Reel, 4000	Green
TPA5972-VS1R	-40 to 125°C	MSOP8	A5972	1	Tape and Reel, 3000	Green
TPA5972-WLPR	-40 to 125°C	WLCSP	AAS	1	Tape and Reel, 3000	Green

(1) For future products, contact the 3PEAK factory for more information and samples.

**Green:** 3PEAK defines "Green" to mean RoHS compatible and free of halogen substances.

---

**5-V, 10-MHz, Zero-Crossover, Low Input Bias Current, RRIO, High Precision Operational Amplifier****IMPORTANT NOTICE AND DISCLAIMER**

**Copyright**© 3PEAK 2012-2025. All rights reserved.

**Trademarks.** Any of the 思瑞浦 or 3PEAK trade names, trademarks, graphic marks, and domain names contained in this document /material are the property of 3PEAK. You may NOT reproduce, modify, publish, transmit or distribute any Trademark without the prior written consent of 3PEAK.

**Performance Information.** Performance tests or performance range contained in this document/material are either results of design simulation or actual tests conducted under designated testing environment. Any variation in testing environment or simulation environment, including but not limited to testing method, testing process or testing temperature, may affect actual performance of the product.

**Disclaimer.** 3PEAK provides technical and reliability data (including data sheets), design resources (including reference designs), application or other design recommendations, networking tools, security information and other resources "As Is". 3PEAK makes no warranty as to the absence of defects, and makes no warranties of any kind, express or implied, including without limitation, implied warranties as to merchantability, fitness for a particular purpose or non-infringement of any third-party's intellectual property rights. Unless otherwise specified in writing, products supplied by 3PEAK are not designed to be used in any life-threatening scenarios, including critical medical applications, automotive safety-critical systems, aviation, aerospace, or any situations where failure could result in bodily harm, loss of life, or significant property damage. 3PEAK disclaims all liability for any such unauthorized use.

This page intentionally left blank