

Features

- Supply Voltage: 4.5 V to 40 V
- Offset Voltage: ±3.5 mV Maximum at 25°C
- Bandwidth: 4 MHz
- Slew Rate: 15 V/μs
- High PSRR+: 90dB at 100kHz
- Differential Input Voltage Range to Supply Rail, can Work as Comparator
- Operating Temperature Range: -40°C to 125°C

Applications

- Instrumentation
- Active Filters, ASIC Input, and Output Amplifier
- Sensor Interface
- Motor Control
- Industrial Control

Description

The TPA265x is a series of the newest high-supply voltage amplifiers with low offset, low power, and stable high-frequency response. The TPA265X incorporates 3PEAK's proprietary and patented design techniques to achieve excellent AC performance with 4 MHz bandwidth, 15 V/μs slew rate. The high PSRR performance increases immunity to high-frequency noise from the power supply. The series can be used as plug-in replacements for commercially.

The combination of features makes these devices optimal for industrial control, motor control, and other applications requiring robust amplifiers with high immunity to power.

Typical Application Circuit

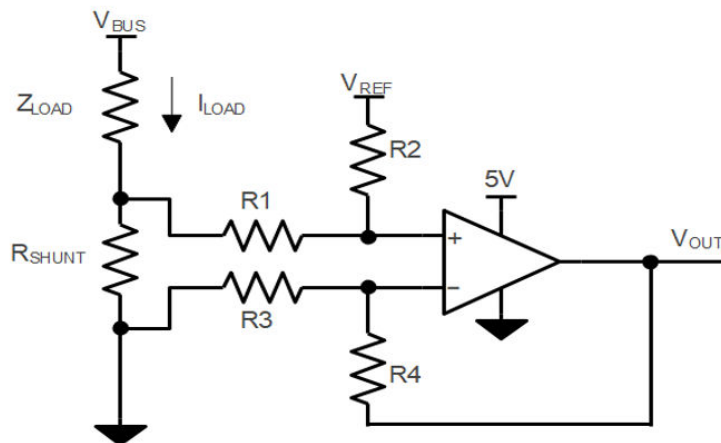

$$V_{OUT} = (I_{LOAD} \times R_{SHUNT}) \times (R2 / R1) + V_{REF}$$

$$\text{When } R3 = R1, R2 = R4, R_{SHUNT} \ll R1$$

Table of Contents

Features	1
Applications	1
Description	1
Typical Application Circuit	1
Revision History	3
Pin Configuration and Functions	4
Specifications	6
Absolute Maximum Ratings ⁽¹⁾	6
ESD, Electrostatic Discharge Protection.....	6
Recommended Operating Conditions.....	6
Thermal Information.....	7
Electrical Characteristics.....	8
Typical Performance Characteristics.....	10
Detailed Description	14
Overview.....	14
Functional Block Diagram.....	14
Feature Description.....	14
Application and Implementation	15
Application Information	15
Tape and Reel Information	16
Package Outline Dimensions	17
SOP8.....	17
SOP14.....	18
Order Information	19
IMPORTANT NOTICE AND DISCLAIMER	20

Revision History

Date	Revision	Notes
2026-03-11	Rev.A.0	Initial Version.

Pin Configuration and Functions

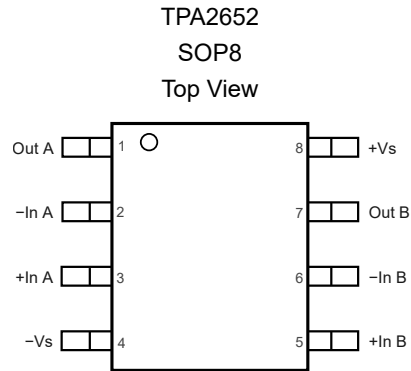
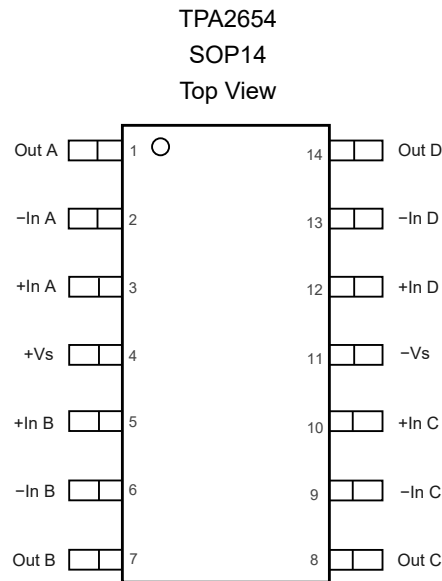

Table 1. Pin Functions: TPA2652

Pin No.	Name	I/O	Description
SOP8			
1	Out A	O	Output
2	-In A	I	Inverting input
3	+In A	I	Non-inverting input
4	-Vs		Negative power supply
5	+In B	I	Non-inverting input
6	-In B	I	Inverting input
7	Out B	O	Output
8	+Vs		Positive power supply

40-V, 4-MHz, 15-V/ μ s, Bipolar Operational Amplifier

Table 2. Pin Functions: TPA2654

Pin No.	Name	I/O	Description
SOP14			
1	Out A	O	Output
2	-In A	I	Inverting input
3	+In A	I	Non-inverting input
4	+Vs		Positive power supply
5	+In B	I	Non-inverting input
6	-In B	I	Inverting input
7	Out B	O	Output
8	Out C	O	Output
9	-In C	I	Inverting input
10	+In C	I	Non-inverting input
11	-Vs		Negative power supply
12	+In D	I	Non-inverting input
13	-In D	I	Inverting input
14	Out D	O	Output

Specifications

Absolute Maximum Ratings ⁽¹⁾

Parameter		Min	Max	Unit
	Supply Voltage, (+V _S) – (–V _S)		42	V
	Input Voltage	(–V _S) – 0.3	(+V _S) + 0.3	V
	Differential Input Voltage	(–V _S) – (+V _S)	(+V _S) – (–V _S)	V
	Input Current: +IN, –IN ⁽²⁾	–10	10	mA
	Output Voltage	(–V _S) – 0.3	(+V _S) + 0.3	V
	Output Short-Circuit Duration ⁽³⁾		Infinite	
T _J	Maximum Junction Temperature		150	°C
T _A	Operating Temperature Range	–40	125	°C
T _{STG}	Storage Temperature Range	–65	150	°C
T _L	Lead Temperature (Soldering, 10 sec)		260	°C

- (1) Stresses beyond those listed under Absolute Maximum Ratings may cause permanent damage to the device. Exposure to any Absolute Maximum Rating condition for extended periods may affect device reliability and lifetime.
- (2) The inputs are protected by ESD-protection diodes to each power supply. If the input extends more than 300 mV beyond the negative power supply, the input current should be limited to less than 10 mA.
- (3) A heat sink may be required to keep the junction temperature below the absolute maximum rating. This depends on the power dissipation of the application. The thermal resistance varies with the amount of PC board metal connected to the package.

ESD, Electrostatic Discharge Protection

Symbol	Parameter	Condition	Minimum Level	Unit
HBM	Human Body Model ESD	ANSI/ESDA/JEDEC JS-001 ⁽¹⁾	2	kV
CDM	Charged Device Model ESD	ANSI/ESDA/JEDEC JS-002 ⁽²⁾	1	kV

- (1) JEDEC document JEP155 states that 500-V HBM allows safe manufacturing with a standard ESD control process.
- (2) JEDEC document JEP157 states that 250-V CDM allows safe manufacturing with a standard ESD control process.

Recommended Operating Conditions

Parameter		Min	Typ	Max	Unit
V _S	Supply Voltage, (+V _S) – (–V _S)	4.5		40	V
T _A	Operating Temperature Range	–40		125	°C

Thermal Information

Package Type	θ_{JA}	θ_{JC}	Unit
SOP8	158	43	$^{\circ}\text{C}/\text{W}$
SOP14	120	36	$^{\circ}\text{C}/\text{W}$

40-V, 4-MHz, 15-V/ μ s, Bipolar Operational Amplifier
Electrical Characteristics

 All test conditions: $V_S = 36\text{ V}$, $T_A = 25^\circ\text{C}$, $R_L = 10\text{ k}\Omega$, unless otherwise noted.

Symbol	Parameter	Conditions	Min	Typ	Max	Unit
Power Supply						
V_S	Supply Voltage Range	$(+V_S) - (-V_S)$	4.5		40	V
I_Q	Quiescent Current per Amplifier	$V_S = 36\text{ V}$		1.65	1.75	mA
		$V_S = 36\text{ V}$, $T_A = -40^\circ\text{C}$ to 125°C			1.75	mA
PSRR	Power Supply Rejection Ratio	$V_S = 5\text{ V}$ to 36 V	87	95		dB
		$V_S = 5\text{ V}$ to 36 V , $T_A = -40^\circ\text{C}$ to 125°C	85			dB
Input Characteristics						
V_{OS}	Input Offset Voltage	$V_S = 36\text{ V}$, $V_{CM} = 18\text{ V}$	-3.5	0.5	3.5	mV
		$V_S = 36\text{ V}$, $V_{CM} = 18\text{ V}$, $T_A = -40^\circ\text{C}$ to 125°C	-5		5	mV
$V_{OS\ TC}$	Input Offset Voltage Drift	$T_A = -40^\circ\text{C}$ to 125°C		6		$\mu\text{V}/^\circ\text{C}$
I_B	Input Bias Current	$V_S = 36\text{ V}$, $V_{CM} = 0\text{ V}$	-35	-5	0	nA
		$V_S = 36\text{ V}$, $V_{CM} = 0\text{ V}$, $T_A = -40^\circ\text{C}$ to 125°C	-50			nA
I_{OS}	Input Offset Current	$V_S = 36\text{ V}$, $V_{CM} = 0\text{ V}$	0	2	10	nA
		$V_S = 36\text{ V}$, $V_{CM} = 0\text{ V}$, $T_A = -40^\circ\text{C}$ to 125°C			15	nA
C_{IN}	Input Capacitance	Differential mode		2		pF
		Common mode		4		pF
A_V	Open-Loop Voltage Gain	$V_{OUT} = -10\text{ V}$ to 10 V	90	103		dB
		$V_{OUT} = -10\text{ V}$ to 10 V , $T_A = -40^\circ\text{C}$ to 125°C	85			dB
V_{CMR}	Common-Mode Input Voltage Range	$T_A = -40^\circ\text{C}$ to 125°C	$(-V_S)$		$\frac{(+V_S) - 2}{2}$	V
CMRR	Common-Mode Rejection Ratio	$V_{CM} = 0\text{ V}$ to 32.5 V	80	99		dB
		$V_{CM} = 0\text{ V}$ to 32.5 V , $T_A = -40^\circ\text{C}$ to 125°C	75			dB
		$V_{CM} = 0\text{ V}$ to 36 V	48	51		dB
		$V_{CM} = 0\text{ V}$ to 36 V , $T_A = -40^\circ\text{C}$ to 125°C	46			dB
Output Characteristics						
V_{OH}	Output Swing from Positive Rail	$R_L = 10\text{ k}\Omega$ to $V_S / 2$		0.8	1.2	V
		$R_L = 10\text{ k}\Omega$ to $V_S / 2$, $T_A = -40^\circ\text{C}$ to 125°C			1.5	V
		$R_L = 2\text{ k}\Omega$ to $V_S / 2$		1.8	2.0	V

40-V, 4-MHz, 15-V/ μ s, Bipolar Operational Amplifier

Symbol	Parameter	Conditions	Min	Typ	Max	Unit
		$R_L = 2\text{ k}\Omega$ to $V_S / 2$, $T_A = -40^\circ\text{C}$ to 125°C			2.2	V
V_{OL}	Output Swing from Negative Rail	$R_L = 10\text{ k}\Omega$ to $V_S / 2$		1.5	1.8	V
		$R_L = 10\text{ k}\Omega$ to $V_S / 2$, $T_A = -40^\circ\text{C}$ to 125°C			2	V
		$R_L = 2\text{ k}\Omega$ to $V_S / 2$		2.2	2.4	V
		$R_L = 2\text{ k}\Omega$ to $V_S / 2$, $T_A = -40^\circ\text{C}$ to 125°C			2.7	V
I_{SC}	Output Short-Circuit Current	$V_S = 36\text{ V}$, Source Current		25		mA
		$V_S = 36\text{ V}$, Sink Current		35		mA
AC Specifications						
GBW	Gain-Bandwidth Product			4		MHz
SR	Slew Rate	$G = 1$, 10-V step		15		V/ μ s
t_{OR}	Overload Recovery			180		ns
t_s	Settling Time, 0.1%	$G = 1$, 2-V step		1.5		μ s
PM	Phase Margin	$R_L = 10\text{ k}\Omega$, $C_L = 100\text{ pF}$		60		$^\circ$
GM	Gain Margin	$R_L = 10\text{ k}\Omega$, $C_L = 100\text{ pF}$		10		dB
X_{TALK}	Crosstalk	$f = 1\text{ kHz}$, Only for 2CH and 4CH		110		dB
Noise Performance						
E_N	Input Voltage Noise	$f = 0.1\text{ Hz}$ to 10 Hz		6		μV_{PP}
e_N	Input Voltage Noise Density	$f = 1\text{ kHz}$		60		$\text{nV}/\sqrt{\text{Hz}}$
i_N	Input Current Noise	$f = 1\text{ kHz}$		80		$\text{fA}/\sqrt{\text{Hz}}$
THD+N	Total Harmonic Distortion and Noise	$f = 1\text{ kHz}$, $G = 1$, $R_L = 10\text{ k}\Omega$, $V_{OUT} = 3.53\text{ V}_{RMS}$		0.001		%

(1) Provided by design simulation.

Typical Performance Characteristics

All test conditions: $V_S = 36\text{ V}$, $T_A = +25^\circ\text{C}$, unless otherwise noted.

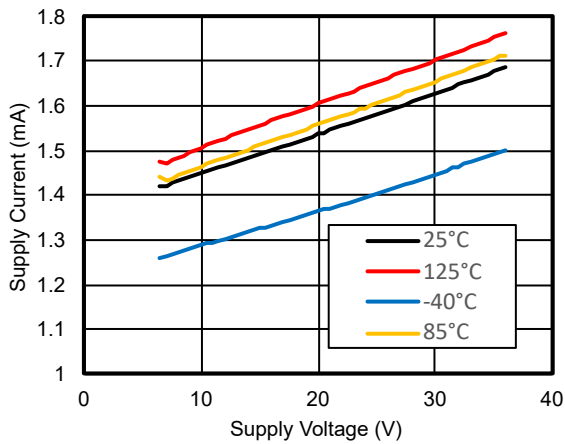

Figure 1. Supply Current vs. Supply Voltage, 1ch

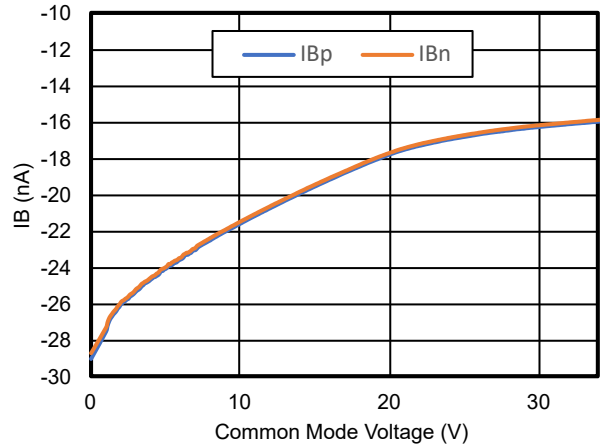

Figure 2. I_B vs. Common-Mode Voltage

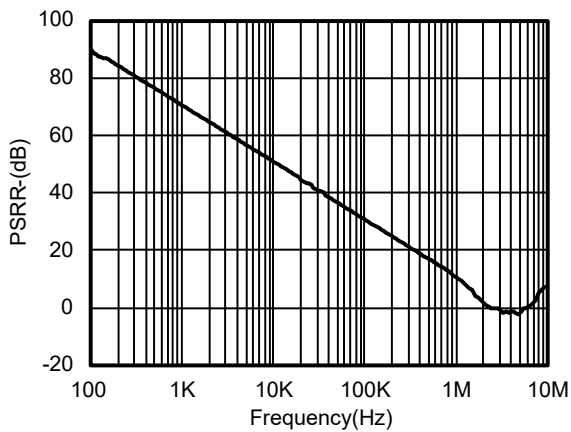

Figure 3. PSRR- vs. Frequency

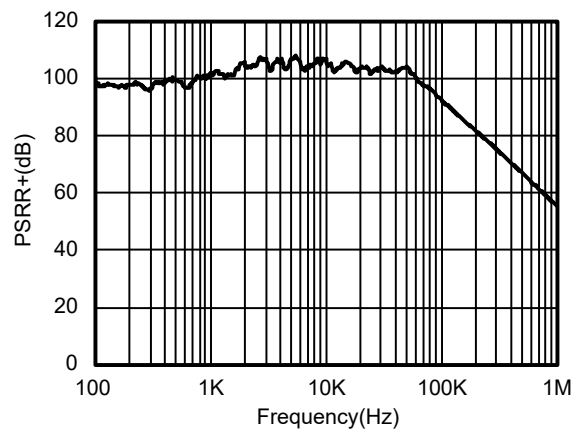

Figure 4. PSRR+ vs. Frequency

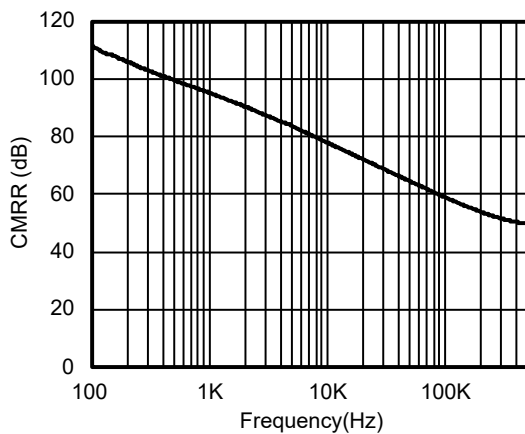

Figure 5. CMRR vs. Frequency

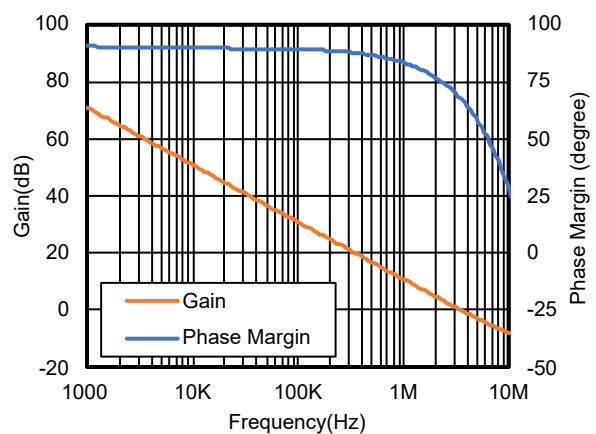

Figure 6. Open-Loop Gain and Phase vs. Frequency

40-V, 4-MHz, 15-V/ μ s, Bipolar Operational Amplifier

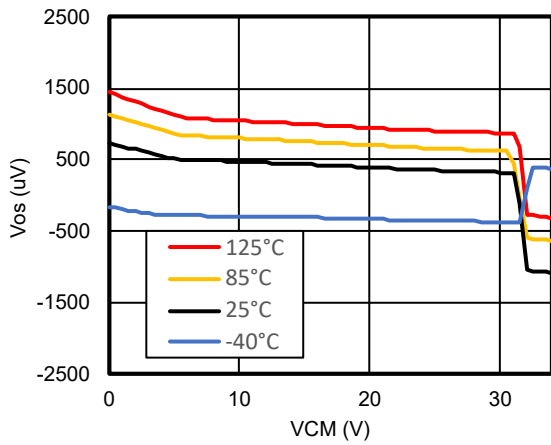

Figure 7. V_{os} vs. Common-Mode Voltage

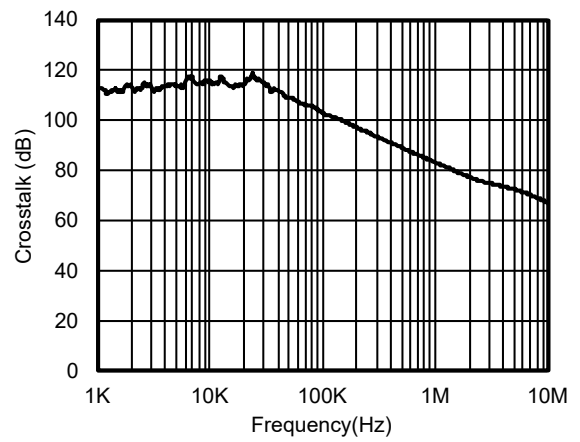

Figure 8. Channel Crosstalk vs. Frequency

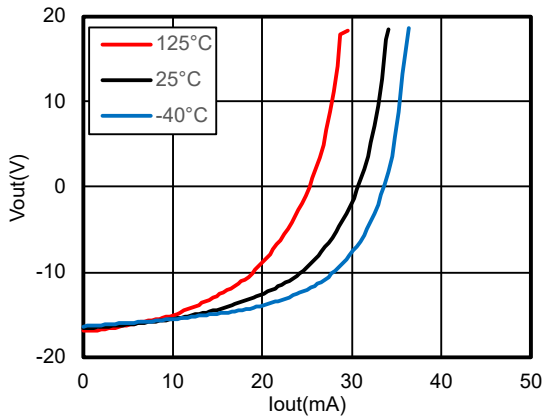

Figure 9. I_{sink} vs. V_{out}

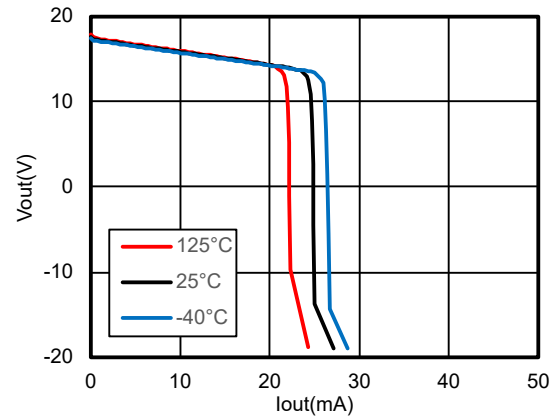

Figure 10. I_{source} vs. V_{out}

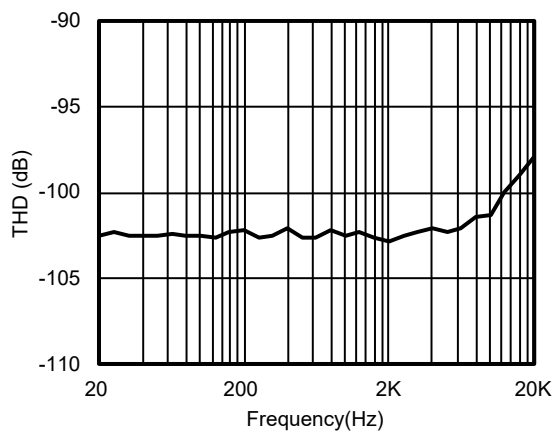

Figure 11. THD + N

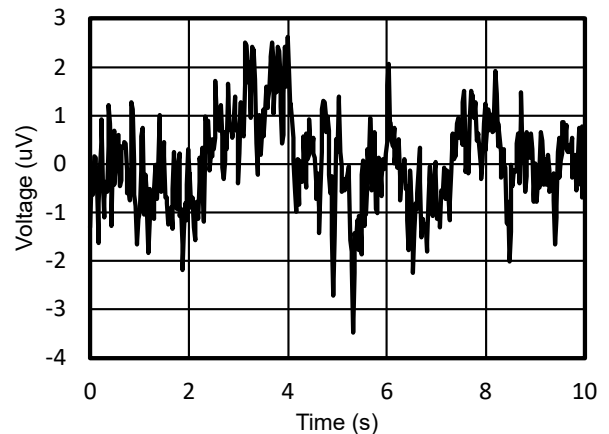
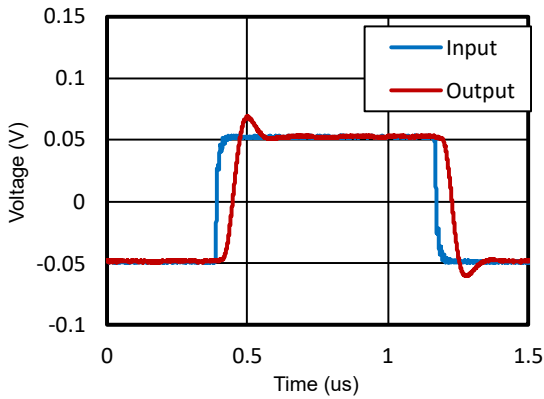
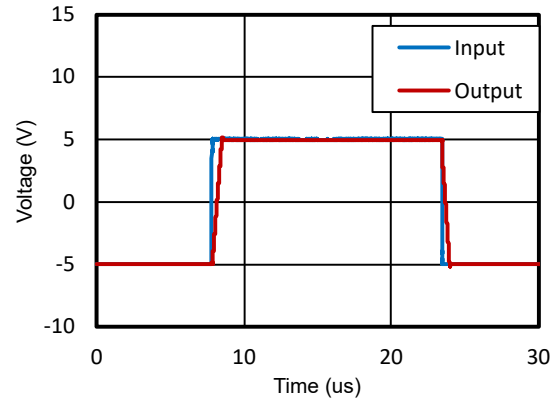
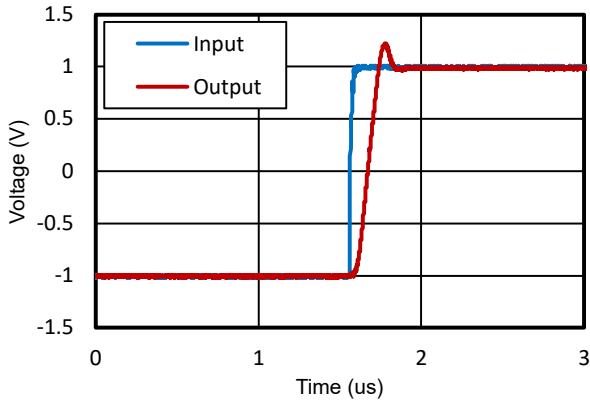
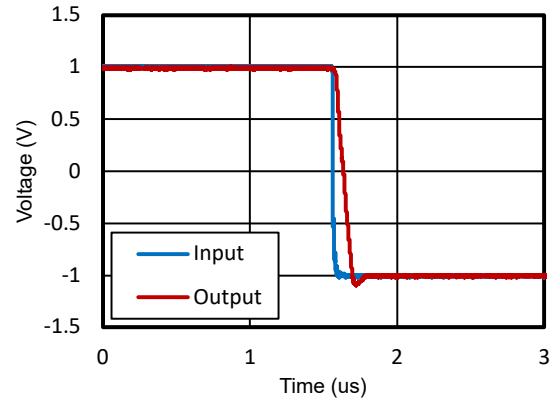
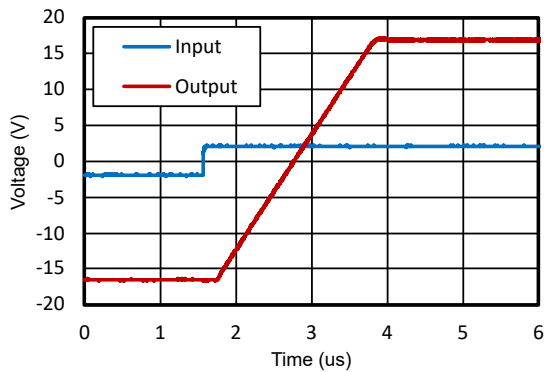
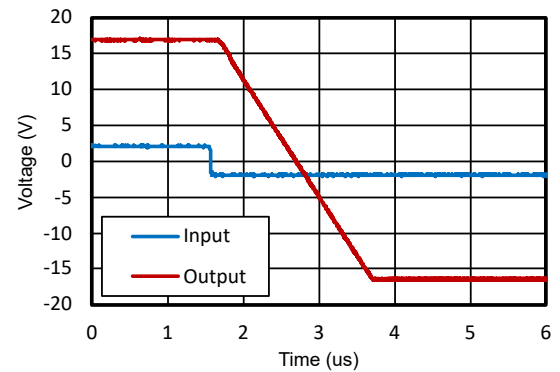

Figure 12. 0.1-Hz to 10-Hz Voltage Noise

Figure 13. 100-mV Small-Signal Step Response

Figure 14. 10-V Large-Signal Step Response

Figure 15. Positive Slew Rate

Figure 16. Negative Slew Rate

Figure 17. Overload Recovery Rise

Figure 18. Overload Recovery Fall

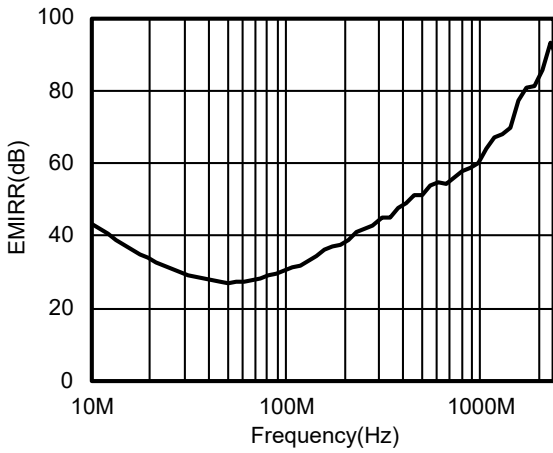

Figure 19. EMIRR vs. Frequency

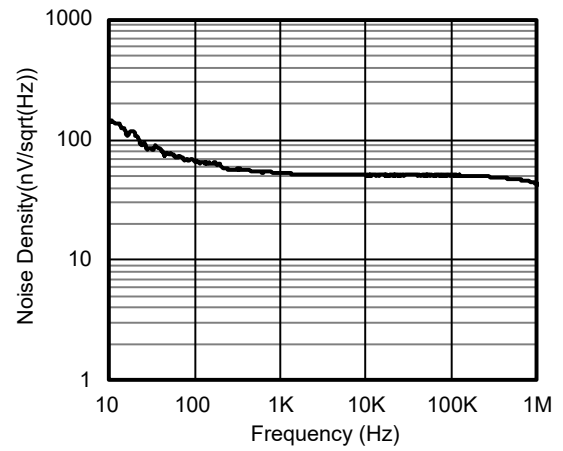

Figure 20. Input Voltage Noise Spectral Density vs. Frequency

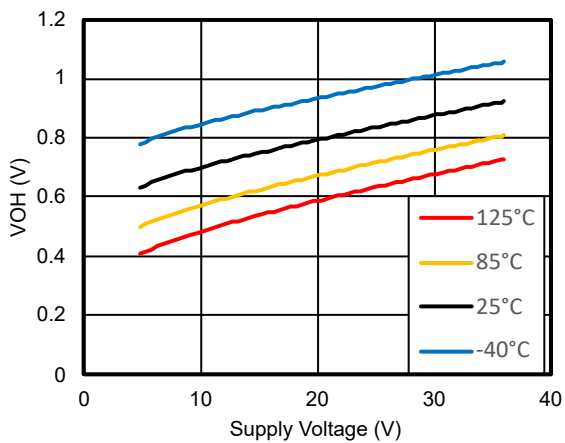

Figure 21. VOH vs. VS with 10-k Ω Load

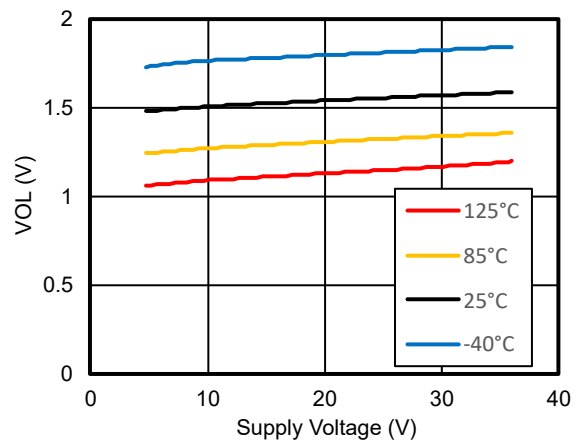

Figure 22. VOL vs. VS with 10-k Ω Load

Detailed Description

Overview

The TPA265x series op amps can operate on a single-supply voltage (4.5 V to 40 V), or a split-supply voltage (± 2.25 V to ± 20 V), making them highly versatile and easy to use. The power-supply pins should have local bypass ceramic capacitors (typically 0.01 μ F to 0.1 μ F). Parameters that can exhibit variance with regard to operating voltage or temperature are presented in the Typical Characteristics.

Functional Block Diagram

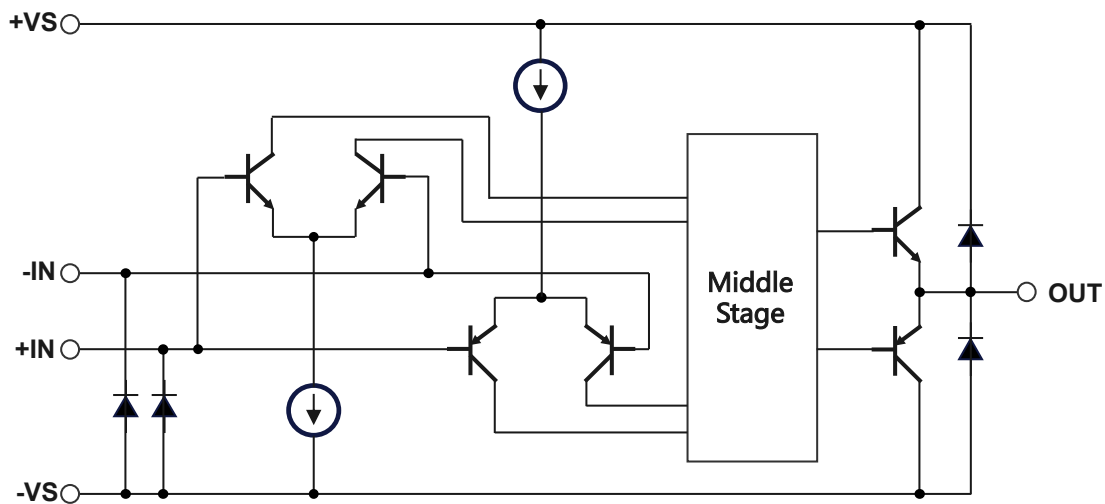

Figure 23. Functional Block Diagram

Feature Description

Operating Voltage

The series is designed for single supply operation from 4.5 V to 40 V or dual supply operation from ± 2.25 V to ± 20 V.

The recommended operating voltage conditions are as follows:

Power supply voltage ($+V_S$) - ($-V_S$): 4.5 V to 40 V. The power supply voltage can support the following three scenarios:

- Single supply;
- Dual supplies with equal voltage values;
- Various voltage configurations, as long as the voltage range of ($+V_S$) - ($-V_S$) is within 4.5 V to 40 V.

For example, if operating with a single supply, ($-V_S$) = 0 V, ($+V_S$) can support 4.5 V to 40 V. If using dual supplies with equal absolute values, the minimum voltage is ± 2.25 V, and the maximum voltage is ± 20 V. It can even support other voltage configurations, such as ($-V_S$) = 100 V, ($+V_S$) = 140 V, or ($-V_S$) = -6 V, ($+V_S$) = 34 V, and so on.

Application and Implementation

Note

Information in the following application sections is not part of the 3PEAK's component specification and 3PEAK does not warrant its accuracy or completeness. 3PEAK's customers are responsible for determining suitability of components for their purposes. Customers should validate and test their design implementation to confirm system functionality.

Application Information

Low-Side Current-Sensing Application

Figure 24 shows the devices configured in a low-side current-sensing application. The low-side current-sensing method is to place a sense resistor between the load and the circuit ground. The voltage dropping across the resistor is amplified by different amplifier circuits with the devices. The V_{REF} can be used to add a bias voltage to the output voltage. Particular attention must be paid to the matching and precision of R1, R2, R3, and R4, to maximize the accuracy of the measurement.

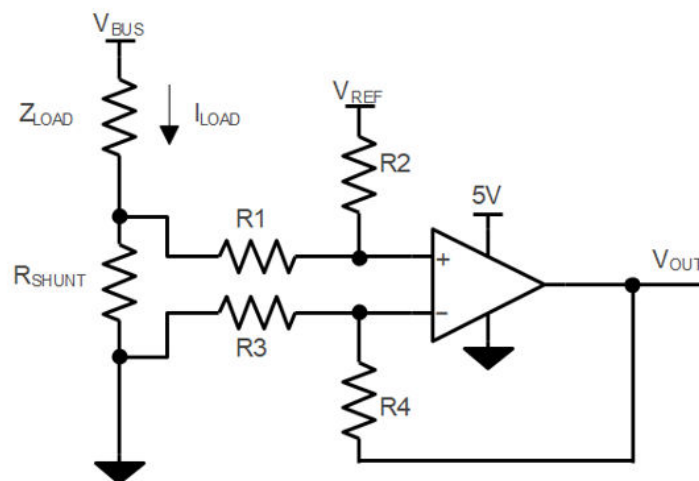

$$V_{OUT} = (I_{LOAD} \times R_{SHUNT}) \times (R2 / R1) + V_{REF}$$

$$\text{When } R3 = R1, R2 = R4, R_{SHUNT} \ll R1$$

Figure 24. Low-Side Current-Sensing Application

Power Supply Recommendations

Place 0.1- μ F bypass capacitors close to the power supply pins to reduce coupling errors from the noise or high-impedance power supplies.

Tape and Reel Information

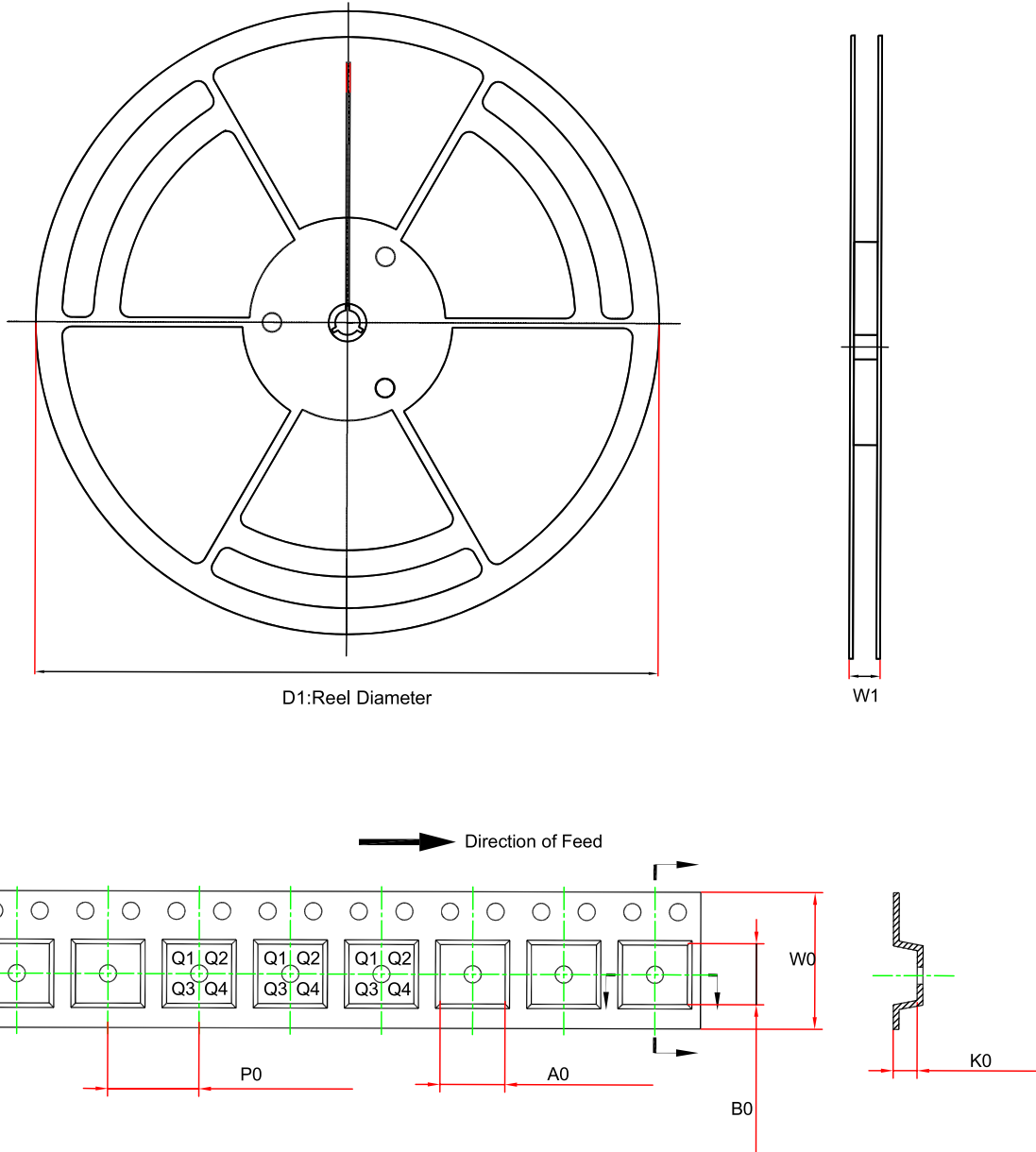

Order Number	Package	D1 (mm)	W1 (mm)	A0 (mm) ⁽¹⁾	B0 (mm) ⁽¹⁾	K0 (mm) ⁽¹⁾	P0 (mm)	W0 (mm)	Pin1 Quadrant
TPA2652-SO1R	SOP8	330	17.6	6.5	5.4	2	8	12	Q1
TPA2654-SO2R	SOP14	330	21.6	6.5	9.3	2.1	8	16	Q1

(1) The value is for reference only. Contact the 3PEAK factory for more information.

Package Outline Dimensions

SOP8

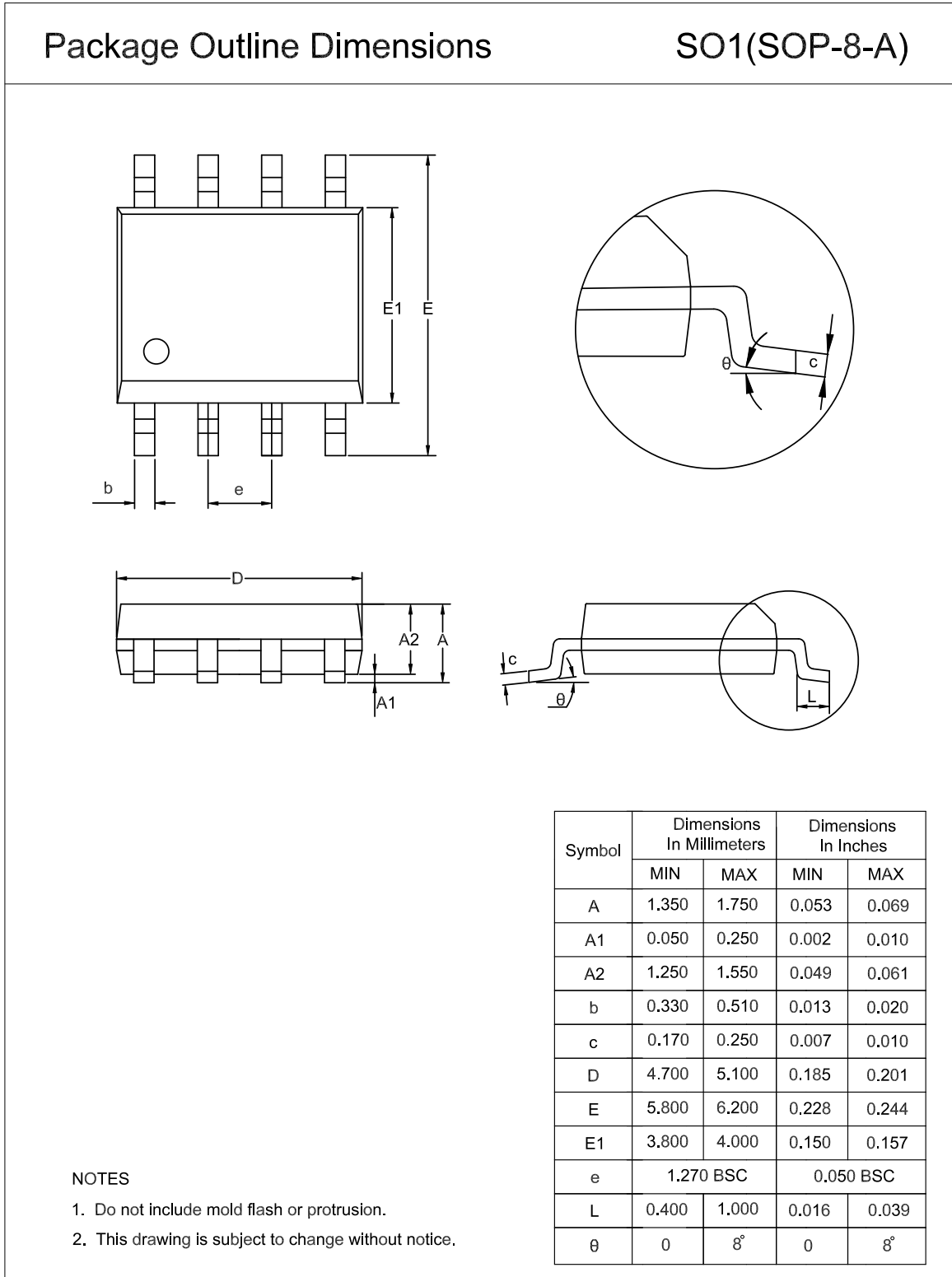

SOP14

Package Outline Dimensions

SO2(SOP-14-A)

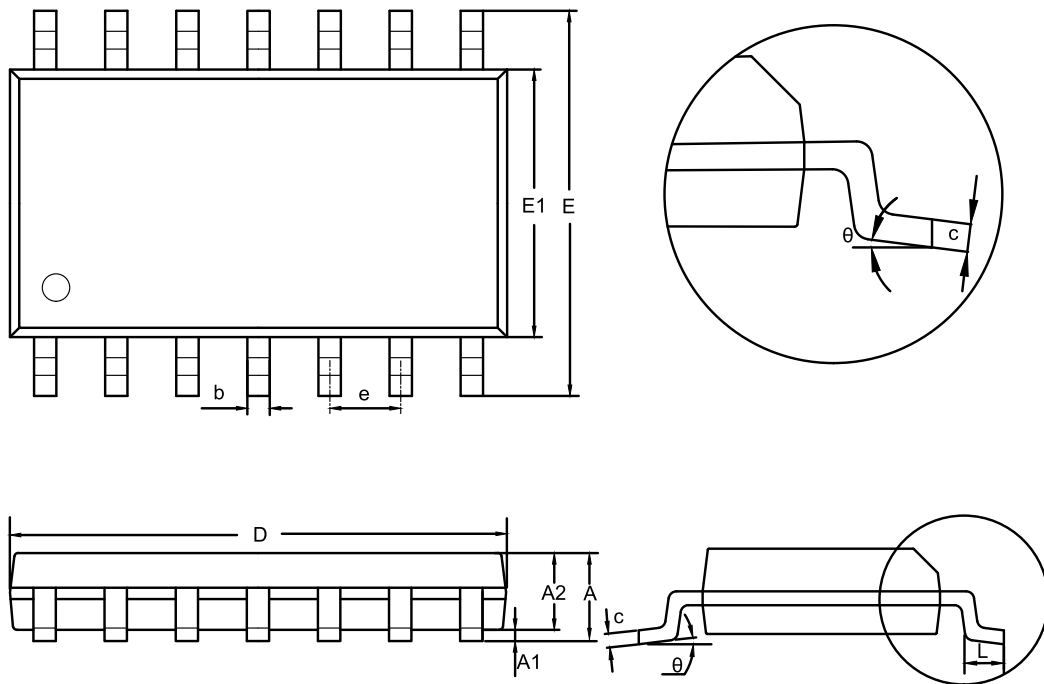

Symbol	Dimensions In Millimeters		Dimensions In Inches	
	MIN	MAX	MIN	MAX
A	1.350	1.750	0.053	0.069
A1	0.050	0.250	0.002	0.010
A2	1.250	1.650	0.049	0.065
b	0.310	0.510	0.012	0.020
c	0.100	0.250	0.004	0.010
D	8.450	8.850	0.333	0.348
E	5.800	6.200	0.228	0.244
E1	3.800	4.000	0.150	0.157
e	1.270 BSC		0.050 BSC	
L	0.400	1.270	0.016	0.050
θ	0	8°	0	8°

NOTES

1. Do not include mold flash or protrusion.
2. This drawing is subject to change without notice.

Order Information

Order Number	Operating Temperature Range	Package	Marking Information	MSL	Transport Media, Quantity	Eco Plan
TPA2652-SO1R	-40 to 125°C	SOP8	A2652	3	Tape and Reel, 4000	Green
TPA2654-SO2R	-40 to 125°C	SOP14	A2654	3	Tape and Reel, 2500	Green

Green: 3PEAK defines "Green" to mean RoHS compatible and free of halogen substances.

IMPORTANT NOTICE AND DISCLAIMER

Copyright© 3PEAK 2012-2026. All rights reserved.

Trademarks. Any of the 思瑞浦 or 3PEAK trade names, trademarks, graphic marks, and domain names contained in this document /material are the property of 3PEAK. You may NOT reproduce, modify, publish, transmit or distribute any Trademark without the prior written consent of 3PEAK.

Performance Information. Performance tests or performance range contained in this document/material are either results of design simulation or actual tests conducted under designated testing environment. Any variation in testing environment or simulation environment, including but not limited to testing method, testing process or testing temperature, may affect actual performance of the product.

Disclaimer. 3PEAK provides technical and reliability data (including data sheets), design resources (including reference designs), application or other design recommendations, networking tools, security information and other resources "As Is". 3PEAK makes no warranty as to the absence of defects, and makes no warranties of any kind, express or implied, including without limitation, implied warranties as to merchantability, fitness for a particular purpose or non-infringement of any third-party's intellectual property rights. Unless otherwise specified in writing, products supplied by 3PEAK are not designed to be used in any life-threatening scenarios, including critical medical applications, automotive safety-critical systems, aviation, aerospace, or any situations where failure could result in bodily harm, loss of life, or significant property damage. 3PEAK disclaims all liability for any such unauthorized use.