

Features

- Enhanced PWM Rejection
- Wide Common-Mode Voltage
 - Operational Voltage: -4 V to 95 V
 - Survival Voltage: -8 V to 100 V
- Supply Voltage: 3.0 V to 5.5 V
- Excellent CMRR
 - 150-dB DC CMRR
 - 115-dB AC CMRR at 50 kHz
- Accuracy and Zero-Drift Performance
 - $120\text{-}\mu\text{V}$ Voltage Offset (Max, -40°C to 125°C)
 - 0.3% Gain Error (Max, -40°C to 125°C)
- Bandwidth: 1 MHz (For A0, A1, A2, A3, A4 Version)
- Excellent Start-up and Power-off Response
- Gain Options for Voltage Output
 - TPA133A0: 10 V/V
 - TPA133A1: 20 V/V
 - TPA133A2: 50 V/V
 - TPA133A3: 100 V/V
 - TPA133A4: 200 V/V
 - TPA133A5: 500 V/V
- -40°C to 125°C Operation Range

Applications

- Current Sensing (High-Side and Low-Side)
- Solenoid and Valve Control
- Power Management

Typical Application Circuit

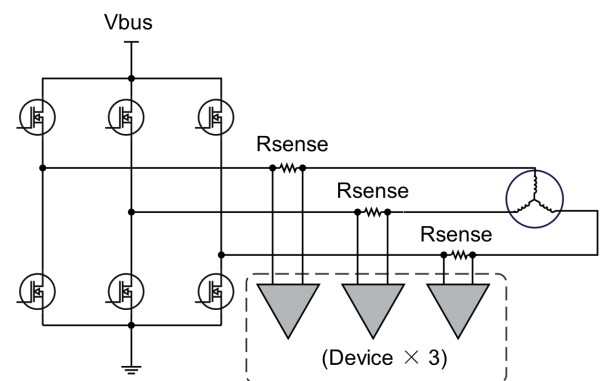

Description

The TPA133 is a current-sense amplifier with a very wide input common-mode voltage range from -4 V to 95 V with a small-signal bandwidth of 1 MHz . The enhanced PWM rejection allows the TPA133 to accommodate the solenoids and motors applications. The device features high-precision accuracy specifications of V_{os} and the gain error, which makes it ideal for the small signal conditioning interfacing with a high-accuracy ADC.

Fixed gains are optional: 10 V/V , 20 V/V , 50 V/V , 100 V/V , 200 V/V , and 500 V/V . The device offers breakthrough performance throughout the temperature range of -40°C to $+125^\circ\text{C}$. The device is offered SOT23-8 and MSOP8 packages.

Many systems, including motors and solenoids, employ PWM signals for modulation or control purposes. However, these PWM signals generate fast common-mode voltage transitions that oscillate between high voltage and ground potential. This can pose a challenge for the current measurement circuitry, as it may result in undesirable output voltage fluctuations. To address this issue, the device incorporates an advanced PWM rejection feature. This feature minimizes the impact of common-mode voltage transitions and ensures stable and reliable output voltage.

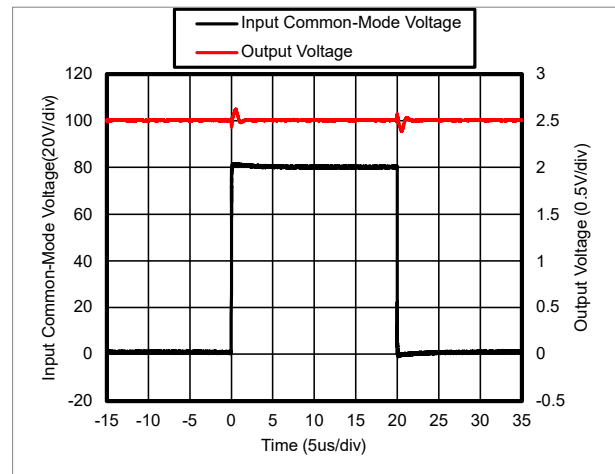

Enhanced PWM Rejection Function

Table of Contents

Features	1
Applications	1
Typical Application Circuit	1
Description	1
Revision History	3
Pin Configuration and Functions	4
Specifications	5
Absolute Maximum Ratings ⁽¹⁾	5
ESD, Electrostatic Discharge Protection.....	5
Thermal Information.....	5
Electrical Characteristics.....	6
Typical Performance Characteristics.....	9
Detailed Description	12
Overview.....	12
Feature Description.....	12
Application and Implementation	14
Application Information	14
Typical Application.....	15
Layout	16
Layout Guideline.....	16
Layout Example.....	16
Tape and Reel Information	17
Package Outline Dimensions	18
MSOP8.....	18
SOT23-8.....	19
Order Information	20
IMPORTANT NOTICE AND DISCLAIMER	21

Revision History

Date	Revision	Notes
2025-02-10	Rev.A.0	Initial version

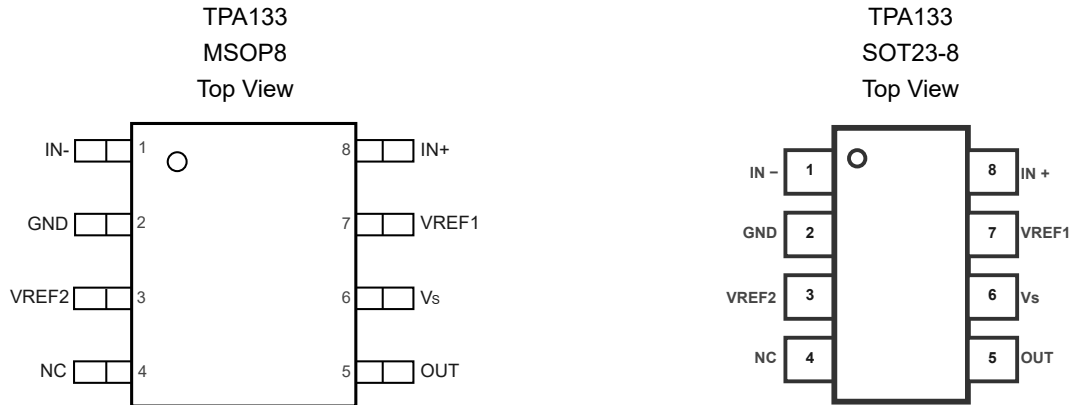
Pin Configuration and Functions

Table 1. Pin Functions: TPA133

Pin No.		Name	I/O	Description
MSOP8	SOT23-8			
1	1	IN-	I	Inverting input.
2	2	GND		Ground.
3	3	VREF2	I	Reference 2 voltage, 0 V to V_S .
4	4	NC		Not connected.
5	5	OUT	O	Output voltage.
6	6	V_S		Power supply, 3 V to 5.5 V.
7	7	VREF1	I	Reference 1 voltage, 0 V to V_S .
8	8	IN+	I	Noninverting input.

Bidirectional, Current-Sense Amplifier with PWM Rejection

Specifications

Absolute Maximum Ratings ⁽¹⁾

Parameter		Min	Max	Unit
V _S	Supply Voltage		6	V
	Input Common Voltage	-8	100	V
	Input Differential Voltage, (IN+) - (IN-)	-10	10	V
	REF1, REF2, NC Inputs	GND - 0.3	V _S + 0.3	V
	Output	GND - 0.3	V _S + 0.3	V
	Input Current: +IN, -IN	-10	+10	mA
T _J	Maximum Operating Junction Temperature		150	°C
T _A	Operating Temperature Range	-40	125	°C
T _{STG}	Storage Temperature Range	-65	150	°C
T _L	Lead Temperature (Soldering, 10 sec)		260	°C

(1) Stresses beyond those listed under Absolute Maximum Ratings may cause permanent damage to the device. Exposure to any Absolute Maximum Rating condition for extended periods may affect device reliability and lifetime.

ESD, Electrostatic Discharge Protection

Symbol	Parameter	Condition	Minimum Level	Unit
HBM	Human Body Model ESD	ANSI/ESDA/JEDEC JS-001 ⁽¹⁾	2	kV
CDM	Charged Device Model ESD	ANSI/ESDA/JEDEC JS-002 ⁽²⁾	1.5	kV

(1) JEDEC document JEP155 states that 500-V HBM allows safe manufacturing with a standard ESD control process.

(2) JEDEC document JEP157 states that 250-V CDM allows safe manufacturing with a standard ESD control process.

Thermal Information

Package Type	θ _{JA}	θ _{JC}	Unit
MSOP8	210	45	°C/W
SOT23-8	196	70	°C/W

Bidirectional, Current-Sense Amplifier with PWM Rejection
Electrical Characteristics

All test conditions: $V_S = 3\text{ V}$, $T_A = 25^\circ\text{C}$, $V_{\text{SENSE}} = (IN+) - (IN-)$, $V_{\text{CM}} = (IN+) = 95\text{ V}$, $V_{\text{REF1}} = V_{\text{REF2}} = V_S / 2$, unless otherwise noted.

Symbol	Parameter	Conditions	Min	Typ	Max	Unit
Input						
V_{OS}	Input Offset Voltage	$V_{\text{SENSE}} = 0\text{ mV}$, $T_A = -40^\circ\text{C}$ to 125°C		± 20	± 120	μV
$V_{\text{OS TC}}$	Input Offset Voltage Drift	$V_{\text{SENSE}} = 0\text{ mV}$, $T_A = -40^\circ\text{C}$ to 125°C		0.15	0.5	$\mu\text{V}/^\circ\text{C}$
$V_{\text{CM}}^{(1)}$	Specified Common-Mode Input Range	$V_{\text{SENSE}} = 0\text{ mV}$, $T_A = -40^\circ\text{C}$ to 125°C	-4		95	V
	Survival Common-Mode Input Range	$V_{\text{SENSE}} = 0\text{ mV}$, $T_A = -40^\circ\text{C}$ to 125°C	-8		100	V
$\text{CMRR}^{(2)}$	Common-Mode Rejection Ratio	$-4\text{ V} < V_{\text{CM}} < 95\text{ V}$, $T_A = -40^\circ\text{C}$ to 125°C	130	150		dB
I_B	Input Bias Current	$V_{\text{SENSE}} = 0\text{ mV}$		1	50	μA
I_{OS}	Input Offset Current	$V_{\text{SENSE}} = 0\text{ mV}$		0.1	1	μA
Noise RTI						
e_n	Input Voltage Noise Density ⁽²⁾	$f = 1\text{ kHz}$		80		$\text{nV}/\sqrt{\text{Hz}}$
Output						
G	Gain	TPA133A0		10		V/V
		TPA133A1		20		V/V
		TPA133A2		50		V/V
		TPA133A3		100		V/V
		TPA133A4		200		V/V
		TPA133A5		500		V/V
GE	Gain Error	TPA133A0, TPA133A1, TPA133A2, TPA133A3, TPA133A4		± 0.05	± 0.2	%
		$T_A = -40^\circ\text{C}$ to 125°C TPA133A0, TPA133A1, TPA133A2, TPA133A3, TPA133A4			± 0.3	%
		TPA133A5		± 0.1	± 0.3	%
		$T_A = -40^\circ\text{C}$ to 125°C TPA133A5			± 0.5	%
	Non-Linearity Error ⁽²⁾	$\text{GND} + 10\text{ mV} \leq V_{\text{OUT}} \leq V_S - 200\text{ mV}$, $T_A = -40^\circ\text{C}$ to 125°C		± 0.01		%
$\text{GE TC}^{(2)}$	Gain Error vs. Temperature	$T_A = -40^\circ\text{C}$ to 125°C TPA133A0, TPA133A1, TPA133A2, TPA133A3		1.5	10	$\text{ppm}/^\circ\text{C}$
		$T_A = -40^\circ\text{C}$ to 125°C TPA133A4, TPA133A5		1.5	12	$\text{ppm}/^\circ\text{C}$

Bidirectional, Current-Sense Amplifier with PWM Rejection

Symbol	Parameter	Conditions	Min	Typ	Max	Unit
C _{LOAD}	Maxim Capacitive Load	No Oscillation		1		nF
V _{OH}	Output Swing from V _S	V _S = 5.5 V, R _L = 10 kΩ to GND		8	25	mV
		V _S = 5.5 V, R _L = 10 kΩ to GND, T _A = -40°C to 125°C			30	mV
V _{OL}	Output Swing from GND	V _S = 5.5 V, R _L = 10 kΩ to GND, V _{SENSE} = 0 mV, V _{REF1} = V _{REF2} = 0 V		3	15	mV
		V _S = 5.5 V, R _L = 10 kΩ to GND, V _{SENSE} = 0 mV, V _{REF1} = V _{REF2} = 0 V, T _A = -40°C to 125°C			20	mV
Reference Input						
	Reference Input Range		0		V _S	V
RVRR	Reference Voltage Rejection Ratio	V _S = 5.5 V, V _{REF1} = V _{REF2} = 0.5 V to (V _S - 0.5 V) TPA133A0		10		μV/V
		V _S = 5.5 V, V _{REF1} = V _{REF2} = 0.5 V to (V _S - 0.5 V) TPA133A1		6		μV/V
		V _S = 5.5 V, V _{REF1} = V _{REF2} = 0.5 V to (V _S - 0.5 V) TPA133A2, TPA133A3		3		μV/V
		V _S = 5.5 V, V _{REF1} = V _{REF2} = 0.5 V to (V _S - 0.5 V) TPA133A4		2		μV/V
		V _S = 5.5 V, V _{REF1} = V _{REF2} = 0.5 V to (V _S - 0.5 V) TPA133A5		1		μV/V
RDA	Reference Divide Accuracy	V _S = 5.5 V, V _{CM} = 95 V, V _{SENSE} = 0 mV, V _{OUT1} : V _{REF1} = GND, V _{REF2} = V _S , V _{OUT2} : V _{REF1} = V _S , V _{REF2} = GND, R _{DA} = (V _{OUT1} - V _{OUT2}) / (V _{OUT1} / 2 + V _{OUT2} / 2), T _A = -40°C to 125°C TPA133A0, TPA133A1, TPA133A2		±0.01	±0.12	%
		V _S = 5.5 V, V _{CM} = 95 V, V _{SENSE} = 0 mV, V _{OUT1} : V _{REF1} = GND, V _{REF2} = V _S , V _{OUT2} : V _{REF1} = V _S , V _{REF2} = GND, R _{DA} = (V _{OUT1} - V _{OUT2}) / (V _{OUT1} / 2 + V _{OUT2} / 2), T _A = -40°C to 125°C TPA133A5		±0.02	±0.25	%
Frequency Response						
BW	Bandwidth	TPA133A0, TPA133A1, TPA133A2, TPA133A3, TPA133A4		1		MHz
		TPA133A5		0.5		MHz

Bidirectional, Current-Sense Amplifier with PWM Rejection

Symbol	Parameter	Conditions	Min	Typ	Max	Unit
SR	Slew Rate	TPA133A0, TPA133A1, TPA133A2, TPA133A3, TPA133A4		11.5		V/ μ s
		TPA133A5		8.5		V/ μ s
Power Supply						
V _S	Supply Voltage	T _A = -40°C to 125°C	3.0		5.5	V
I _Q	Quiescent Current	V _S = 3.0 V		2.5	3	mA
		V _S = 3.0 V, T _A = -40°C to 125°C			3.1	mA
		V _S = 5.5 V		2.9	3.7	mA
		V _S = 5.5 V, T _A = -40°C to 125°C			4	mA
PSRR	Power Supply Rejection Ratio	3.0 V < V _S < 5.5 V, T _A = -40°C to 125°C	80	90		dB

- (1) To keep the device safe, the common-mode voltage at both V_{IN+} and V_{IN-} must not exceed the survival common-mode input range. To guarantee the specification, common-mode voltage at both V_{IN+} and V_{IN-} should be within the specification common-mode input range.
- (2) Provided by bench test and design simulation.

Bidirectional, Current-Sense Amplifier with PWM Rejection

Typical Performance Characteristics

All test conditions: $V_S = 3\text{ V}$, $T_A = 25^\circ\text{C}$, $V_{\text{SENSE}} = (IN+) - (IN-)$, $V_{\text{CM}} = (IN+) = 80\text{ V}$, $V_{\text{REF1}} = V_{\text{REF2}} = V_S / 2$, unless otherwise noted.

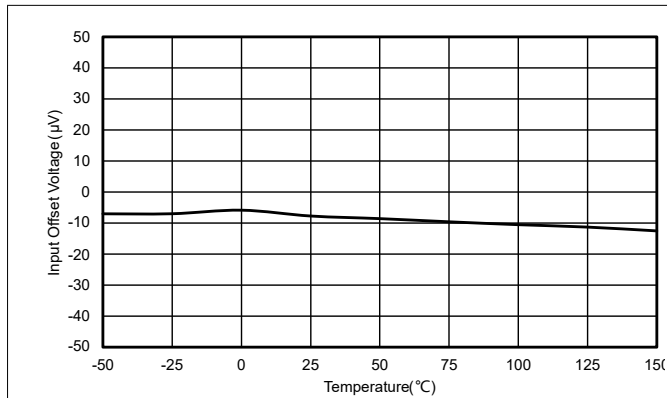

Figure 1. Offset Voltage vs. Temperature

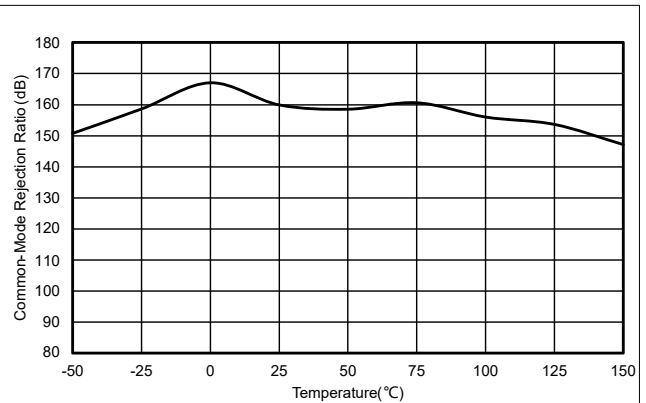

Figure 2. Common-Mode Rejection Ratio vs. Temperature

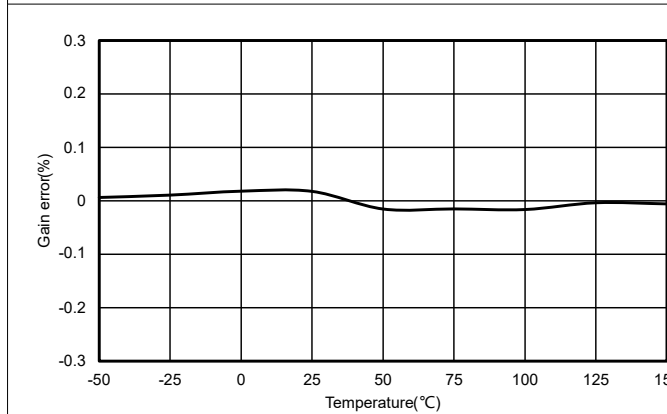

Figure 3. Gain Error vs. Temperature

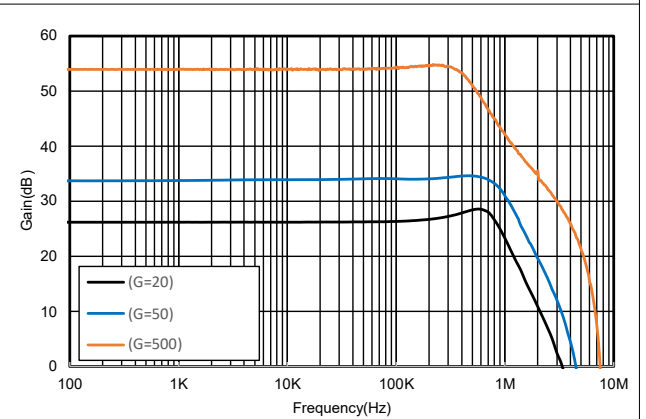

Figure 4. Gain vs. Frequency

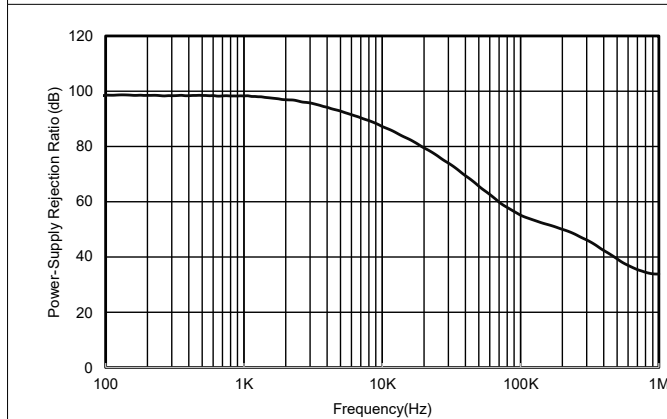

Figure 5. Power-Supply Rejection Ratio vs. Frequency

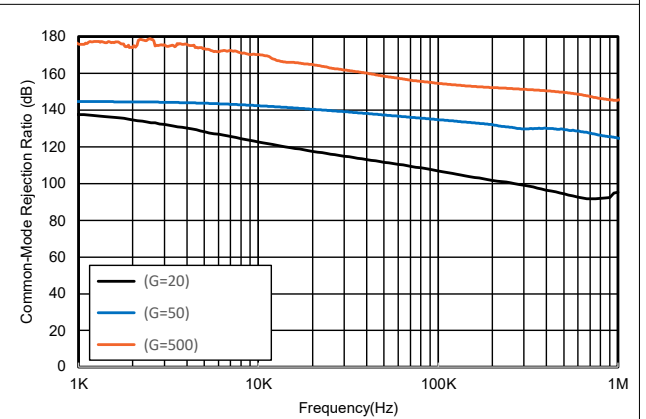

Figure 6. Common-Mode Rejection Ratio vs. Frequency

Bidirectional, Current-Sense Amplifier with PWM Rejection

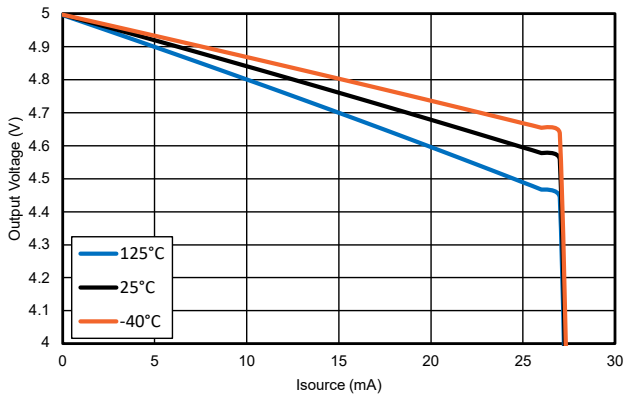

Figure 7. Output Voltage Swing vs. I_{SOURCE}

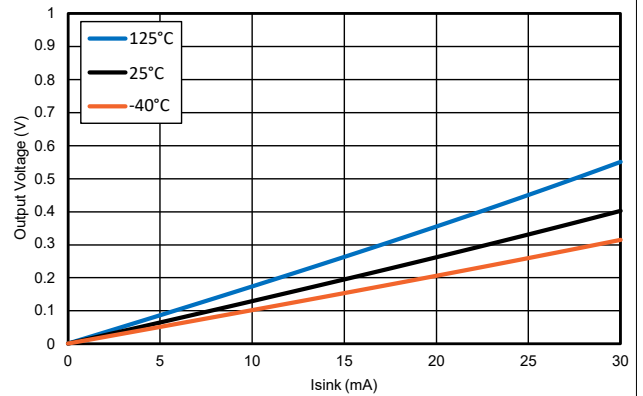

Figure 8. Output Voltage Swing vs. I_{SINK}

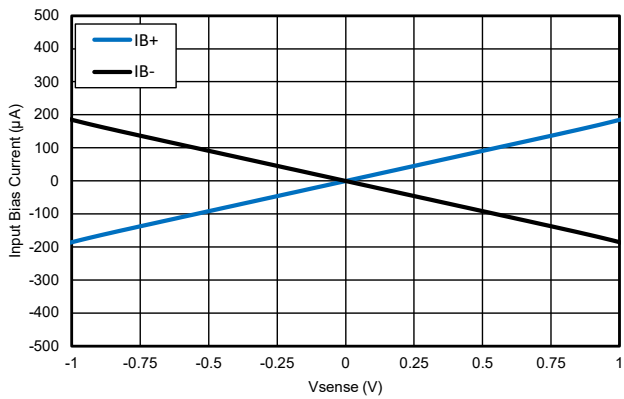

Figure 9. Input Bias Current vs. V_{SENSE}

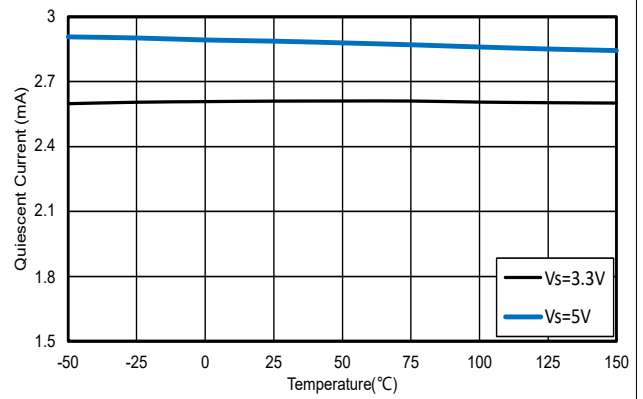

Figure 10. Quiescent Current vs. Temperature

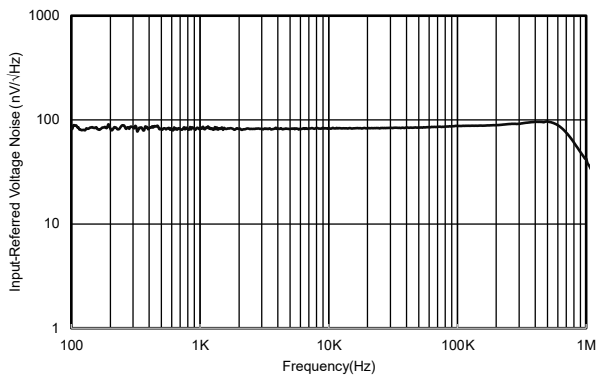

Figure 11. Input-Referred Voltage Noise vs. Frequency

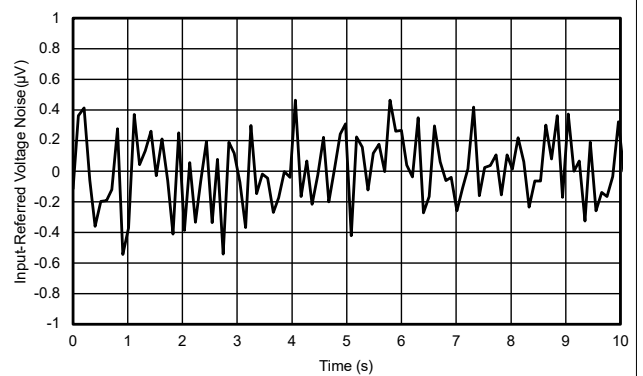

Figure 12. 0.1-Hz to 10-Hz Voltage Noise

Bidirectional, Current-Sense Amplifier with PWM Rejection

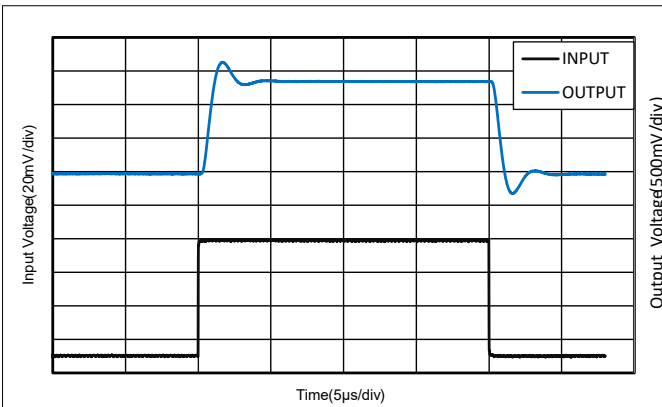
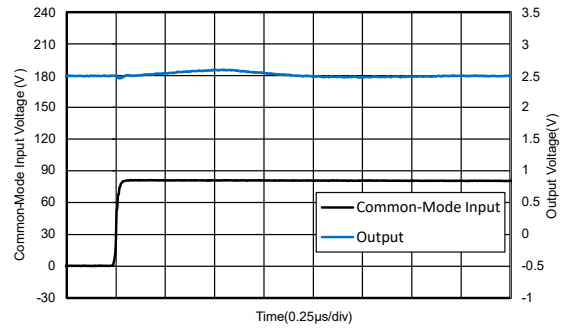
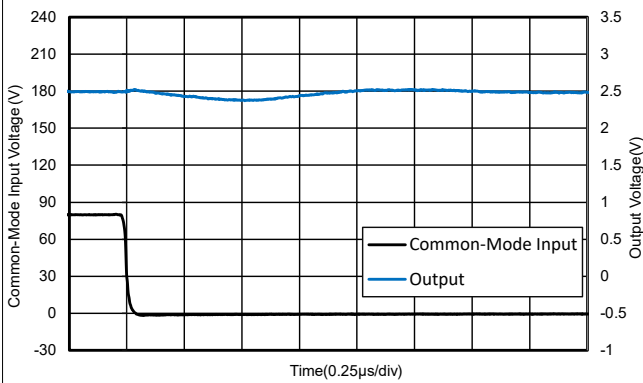

Figure 13. Step Response



$V_{CM} = 0\text{ V to }80\text{ V}$, $T_{rise} = 30\text{ ns}$, $V_{REF1} = V_{REF2} = 2.5\text{ V}$

Figure 14. Common-Mode Voltage Transient Response



$V_{CM} = 80\text{ V to }0\text{ V}$, $T_{fall} = 30\text{ ns}$, $V_{REF1} = V_{REF2} = 2.5\text{ V}$

Figure 15. Common-Mode Voltage Transient Response

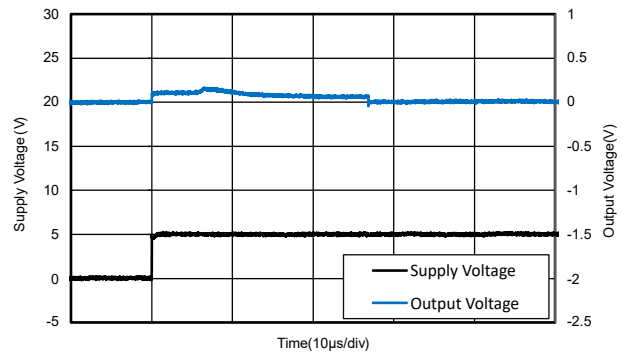

$V_{CC} = 0\text{ V to }5\text{ V}$, $T_{rise} = 30\text{ ns}$, $V_{CM} = 80\text{ V}$, $V_{REF1} = V_{REF2} = 0\text{ V}$

Figure 16. Start-Up Response

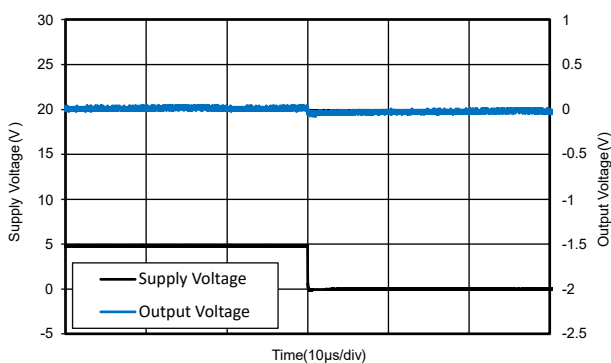

$V_{CC} = 5\text{ V to }0\text{ V}$, $T_{fall} = 30\text{ ns}$, $V_{CM} = 80\text{ V}$, $V_{REF1} = V_{REF2} = 0\text{ V}$

Figure 17. Power-Off Response

Detailed Description

Overview

The TPA133 is a high-precision current-sense amplifier with excellent CMRR. Because of its wide input common-mode voltage range, it can be used both in the high-side and low-side current sensing. The TPA133 features enhanced PWM rejection, and it maintains excellent performance even when the input common mode has fast $\Delta V/\Delta t$ transitions. The TPA133 has a bandwidth of up to 1 MHz and an SR of 11.5 V/ μ s, which makes it suitable for overcurrent protection and loop control systems that require a fast response speed. The TPA133 boasts exceptional performance in both start-up and power-off scenarios. Its meticulously designed output control mechanisms effectively prevent the system from triggering false alarms and ensure stability and reliability.

Feature Description

Wide Input Common-Mode Voltage Range and Enhanced PWM Rejection

The TPA133 supports a -4 -V to 95-V input common-mode voltage that is independent of the supply voltage (V_s). The ability to operate with common-mode voltages greater or less than V_s allows the TPA133 to be used in both high-side and low-side current-sensing applications.

For a typical solenoid application as shown in [Figure 18](#), when the switch is closed, the common-mode voltage across the R_{sense} swings to the battery voltage (e.g. 48 V). When the switch is open, the common-mode voltage across the R_{sense} reverses to one diode drop below ground (e.g. -0.7 V) due to the recirculation. It brings fast common-mode voltage transitions to the amplifier. The TPA133 provides excellent CMRR and enhances the PWM rejection of this application.

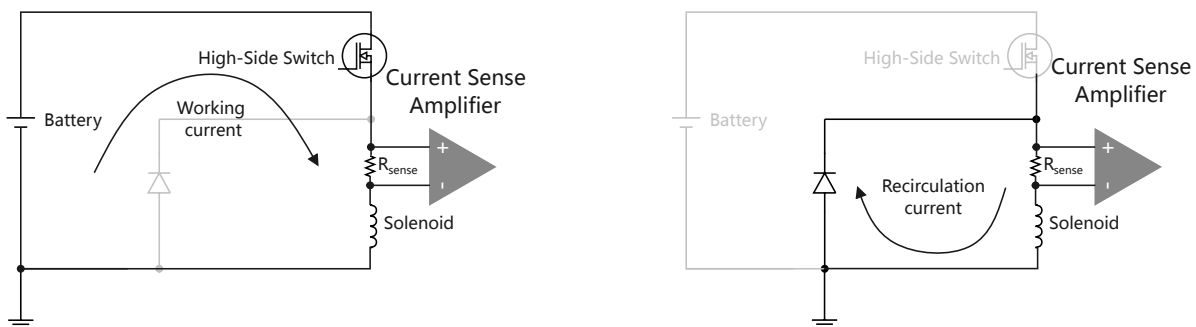

Figure 18. Solenoid Application Circuits

Reference Input, REF

The TPA133 has two reference inputs which range from GND to V_s . It can be used both in unidirectional and bidirectional current sensing operations. The output can be calculated by [Equation 1](#).

$$V_{OUT} = V_{SENSE} \cdot \text{Gain} + \frac{V_{REF1} + V_{REF2}}{2} \quad (1)$$

For Unidirectional Current Sensing

It is a cost-effective solution to connect both REF1 and REF2 to GND or V_s . However, the current measurement close to 0 is incorrect considering V_{OL}/V_{OH} .

Bidirectional, Current-Sense Amplifier with PWM Rejection

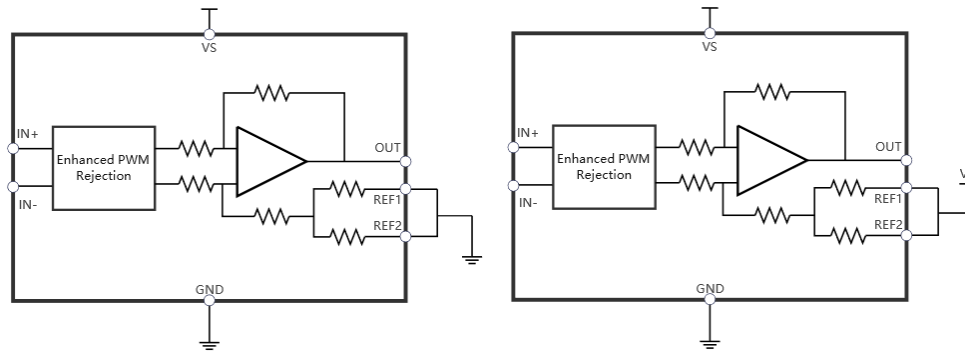

Figure 19. Unidirectional Application Schematic

For Bidirectional Current Sensing

Connecting REF1 to V_S and REF2 to GND is a convenient way to make the output voltage remain $V_S/2$ where there is 0 input. But the output voltage introduces the V_S noise. Connecting REF1 and REF2 to the external reference is a precision but expensive way.

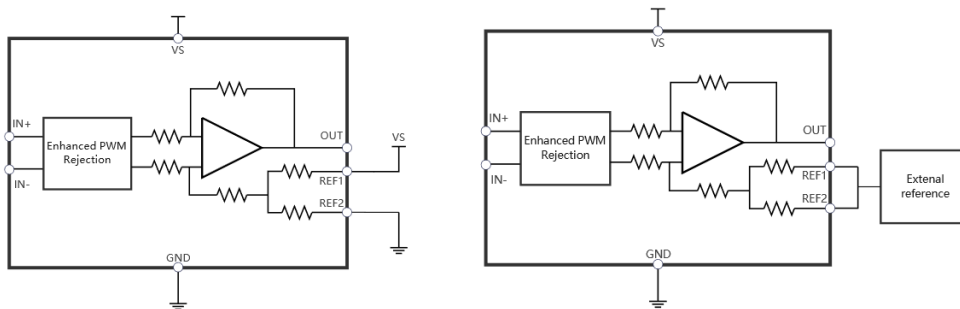

Figure 20. Bidirectional Application Schematic

Excellent start-up and power-off Response

If there is no special treatment, the output of the current-sense amplifier may generate glitches up to the supply voltage during the start-up or power-off of the device. This may cause the system to mistakenly believe that an overcurrent has occurred, leading to fault protection. Using this type of device makes the system more complex and unreliable.

The output of the TPA133 is carefully controlled during its start-up and power-off process to prevent the false triggering of the overcurrent protection, leading to increased reliability and stability. The TPA133 ensures that the output false pulse remains below 700 mV in all scenarios, including:

Various V_{CM} and V_{SENSE} : V_{CM} (common-mode voltage) and V_{SENSE} ($(V_{IN+}) - (V_{IN-})$) are set to any voltage allowed in the Electrical Characteristics table (e.g. $V_{CM} = 80$ V, $V_{SENSE} = 50$ mV), depending on the application requirements. This enables stable operations regardless of whether the bus voltage in the system is present or not.

Various V_{REF} : Same as V_{CM} and V_{SENSE} , V_{REF} (reference voltage) are set to any voltage allowed in the Electrical Characteristics Tables (e.g. $V_{REF} = 0$ V or 2.5 V), allowing for flexibility in adjusting the sensitivity of the current sensor detection circuit.

Various V_{CC} ramp-up and ramp-down rates: V_{CC} (supply voltage) is ramped up or ramped down at different rates ranging from nanoseconds to milliseconds. This makes the TPA133 suitable for complex industrial scenarios.

Application and Implementation

Note

Information in the following application sections is not part of the 3PEAK's component specification and 3PEAK does not warrant its accuracy or completeness. 3PEAK's customers are responsible for determining suitability of components for their purposes. Customers should validate and test their design implementation to confirm system functionality.

Application Information

Selecting the Sense Resistor

The careful selection of an appropriate sense resistor is paramount in achieving accurate and reliable current measurements. To ensure the best performance, it is recommended to carefully evaluate the trade-offs between the resistance value, accuracy, power dissipation, and temperature coefficient.

When selecting a sense resistor, two primary factors should be considered: the desired current measurement range and accuracy, as well as the power dissipation in the resistor. The resistance value and tolerance must be chosen in accordance with the desired current measurement range and the required level of accuracy. Optimizing system performance often involves considering the input voltage across the sense resistor throughout its full dynamic range. However, it is crucial to note that higher resistance values contribute to increased power dissipation, potentially leading to resistor overheating. Moreover, the resistance value may also exhibit drift due to the influence of the temperature coefficient.

Input Filter

The input signal of the TPA133 is sampled by the capacitor with a frequency of about 8 MHz, as shown in [Figure 21](#).

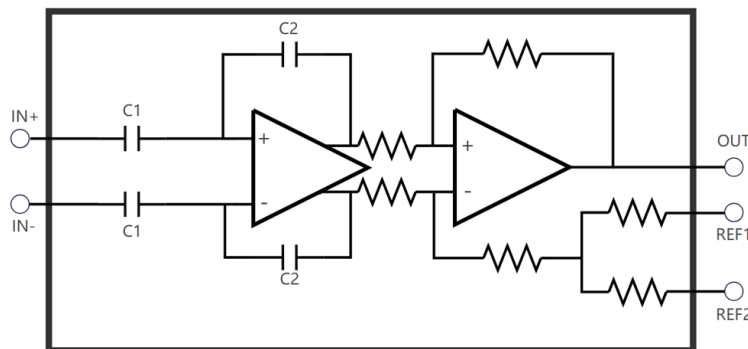

Figure 21. Brief Circuit Diagram of TPA133

According to the Nyquist Sampling Theorem, under-sampling may lead to aliasing. When the noise with a frequency greater than $1/2 * F_{CLK}$ (4 MHz) is present, it may be aliased to lower frequencies by the sampling structure, interfering with the effective signal.

Therefore, it is highly recommended to include an anti-alias filter at the input of the TPA133. A common first-order RC low-pass filter is shown in [Figure 22](#).

Bidirectional, Current-Sense Amplifier with PWM Rejection

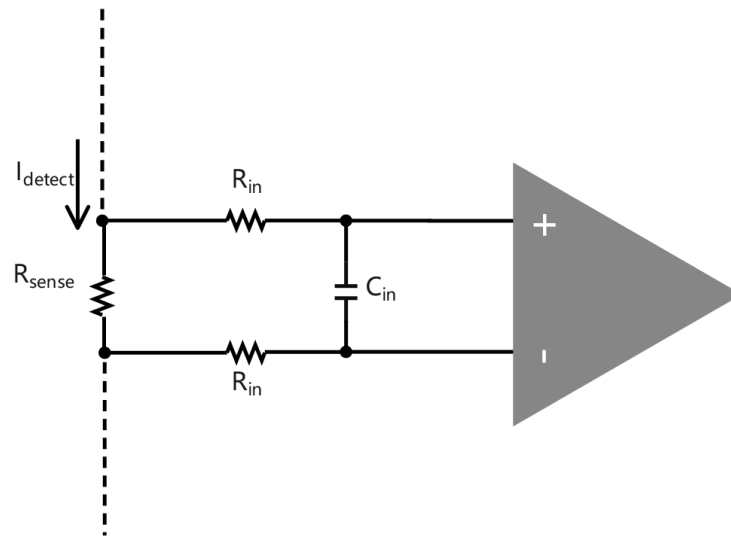

Figure 22. Input Filter Circuit

The bandwidth of the system with filtering can be calculated using [Equation 2](#):

$$BW_{\text{Filter}} = \frac{1}{2\pi (2 \cdot R_{in}) C_{in}} \quad (2)$$

However, it is crucial to be aware of the potential side effects of input filtering. The input resistance R_{in} plays a role in the voltage division with the chip's differential impedance R_{diff} ($5.6 \text{ k}\Omega \pm 15\%$ for the TPA133), which can introduce an additional gain error:

$$\text{Gain Error} = \frac{2 R_{in}}{2 R_{in} + R_{diff}} \quad (3)$$

In general, we have the following suggestions for the input of the TPA133:

1. Add an anti-alias low-pass filter with a cutoff frequency equal to or less than the bandwidth of the TPA133 (1 MHz).
2. To reduce the gain error, it is recommended that R_{in} is less than or equal to 10Ω if the system is not calibrated.

Typical Application

[Figure 23](#) shows the typical application schematic.

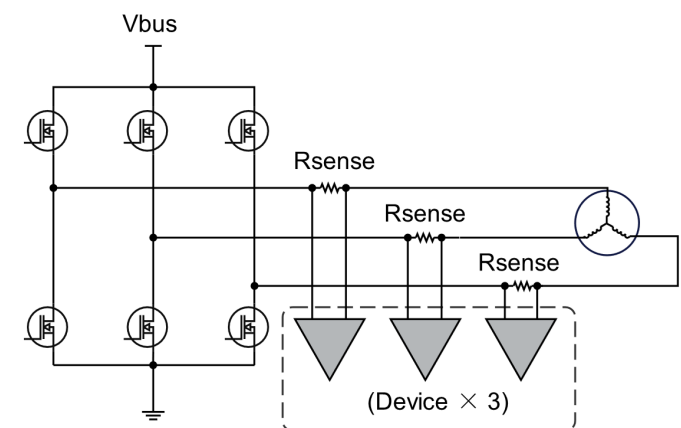

Figure 23. Typical Application Circuit

Layout

Layout Guideline

- When working with high currents through the R_{SENSE} resistor, it's crucial to minimize the errors caused by the solder and parasitic trace resistance. The four-terminal current sense resistor or the Kelvin (force and sense) PCB layout is recommended to ensure accurate current sensing and optimal performance of the TPA133.
- Ensure that the sense resistor has an ample copper trace area to effectively dissipate heat. This minimizes temperature-induced changes in the value of the resistor and maintains the measurement accuracy.
- Place a 0.1- μF bypass capacitor as close as possible to the supply and ground pins of the TPA133. This minimizes the impact of noise and impedance on the power supply and ensures stable operation.
- Place a low-pass filter as close as possible to the input pins of the TPA133. This effectively avoids aliasing and improves measurement accuracy.

Layout Example

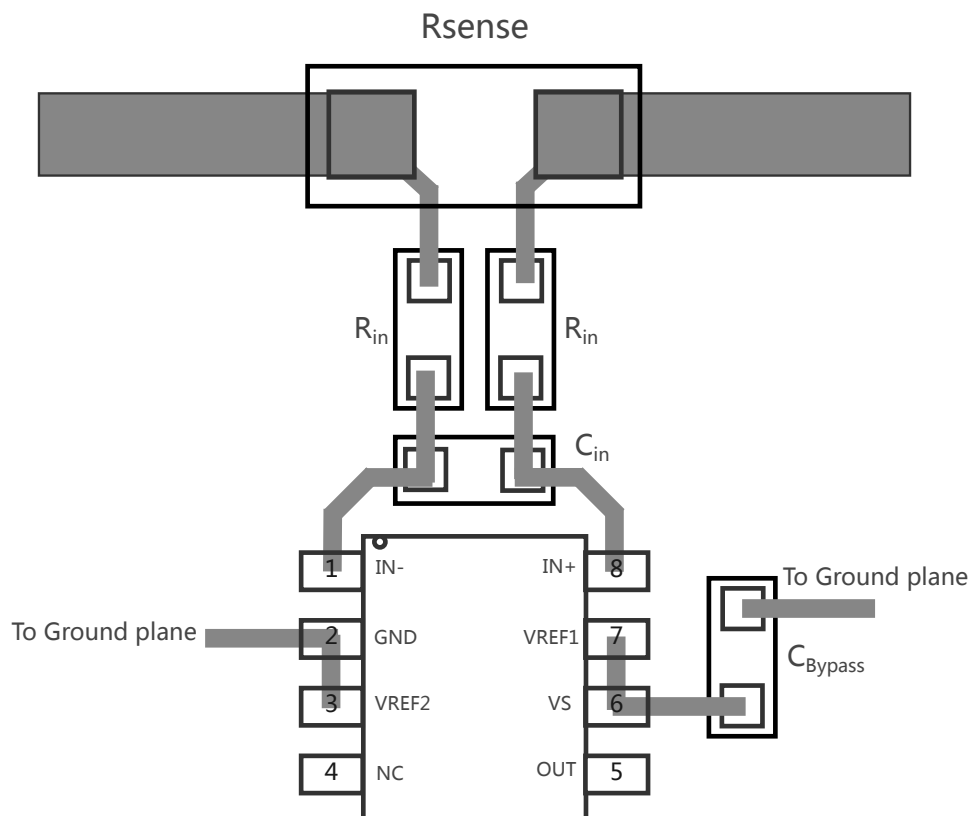
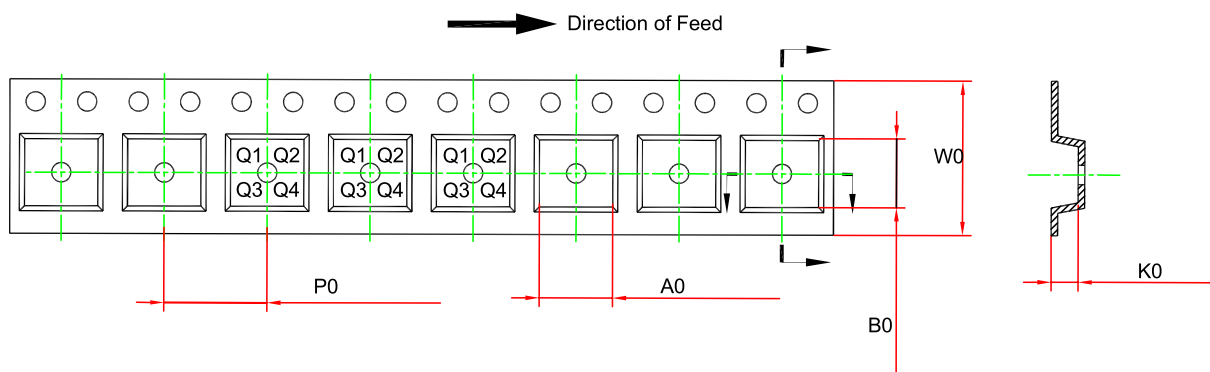
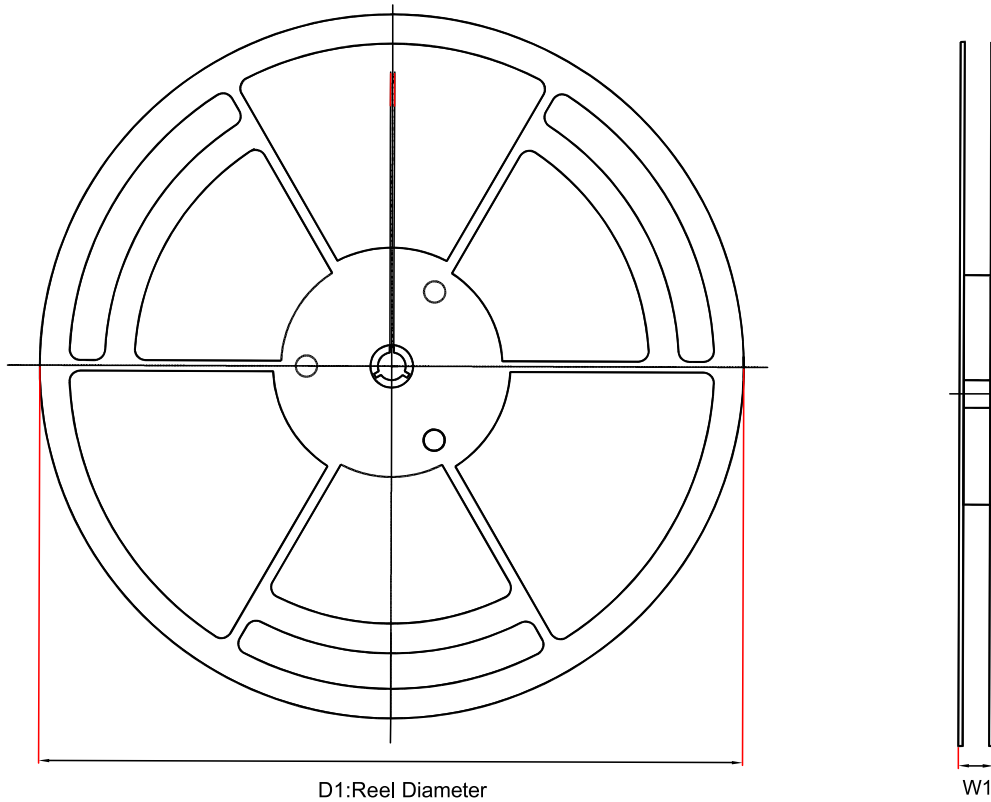

Figure 24. Recommended Layout

Tape and Reel Information



Order Number	Package	D1 (mm)	W1 (mm)	A0 (mm)	B0 (mm)	K0 (mm)	P0 (mm)	W0 (mm)	Pin1 Quadrant
TPA133Ax-VS1R-S	MSOP8	330	17.6	5.3	3.4	1.3	8	12	Q1
TPA133Ax-T8TR-S	SOT23-8	178	13.1	3.3	3.2	1.4	4	8	Q3

Package Outline Dimensions

MSOP8

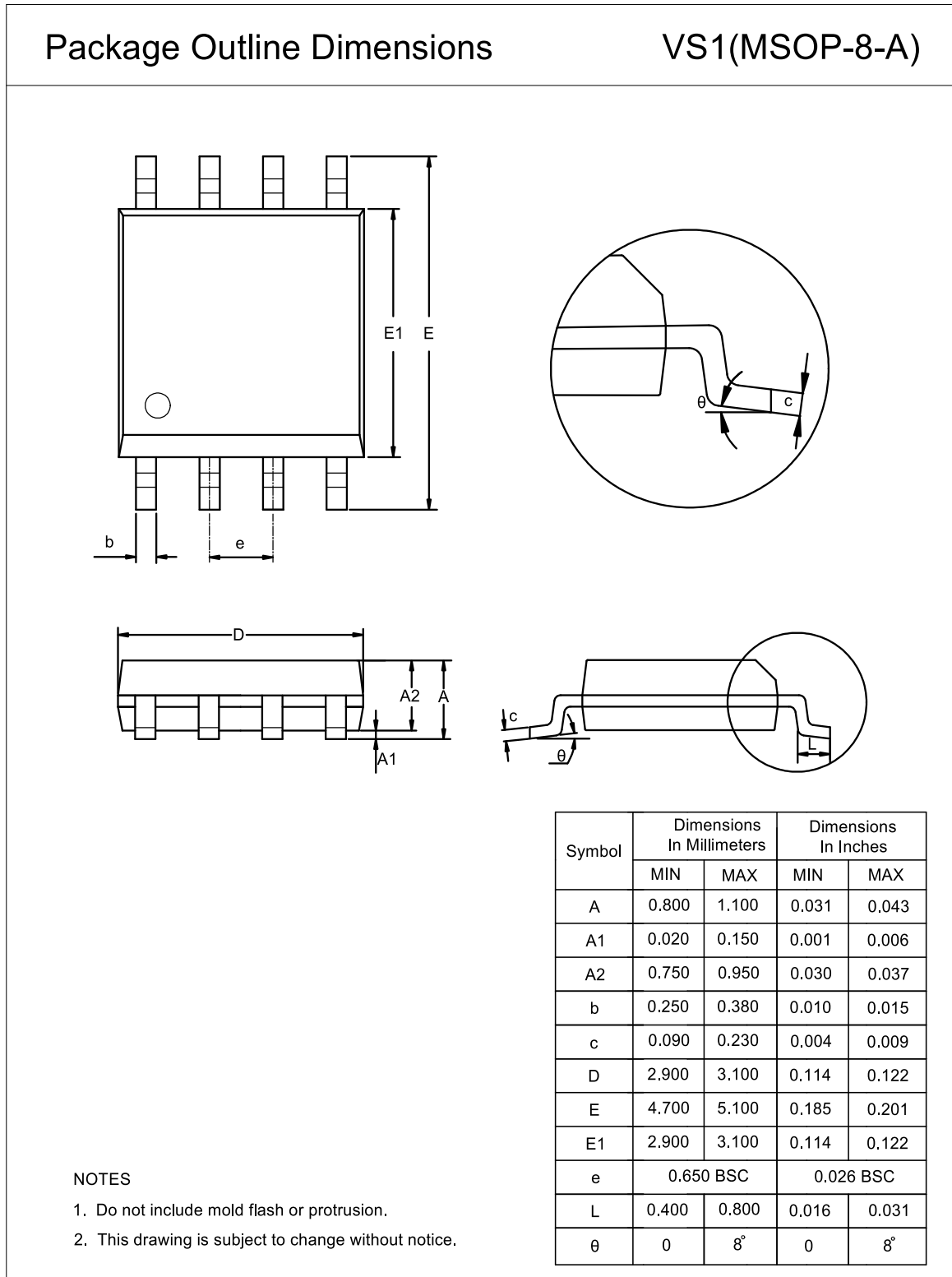

SOT23-8

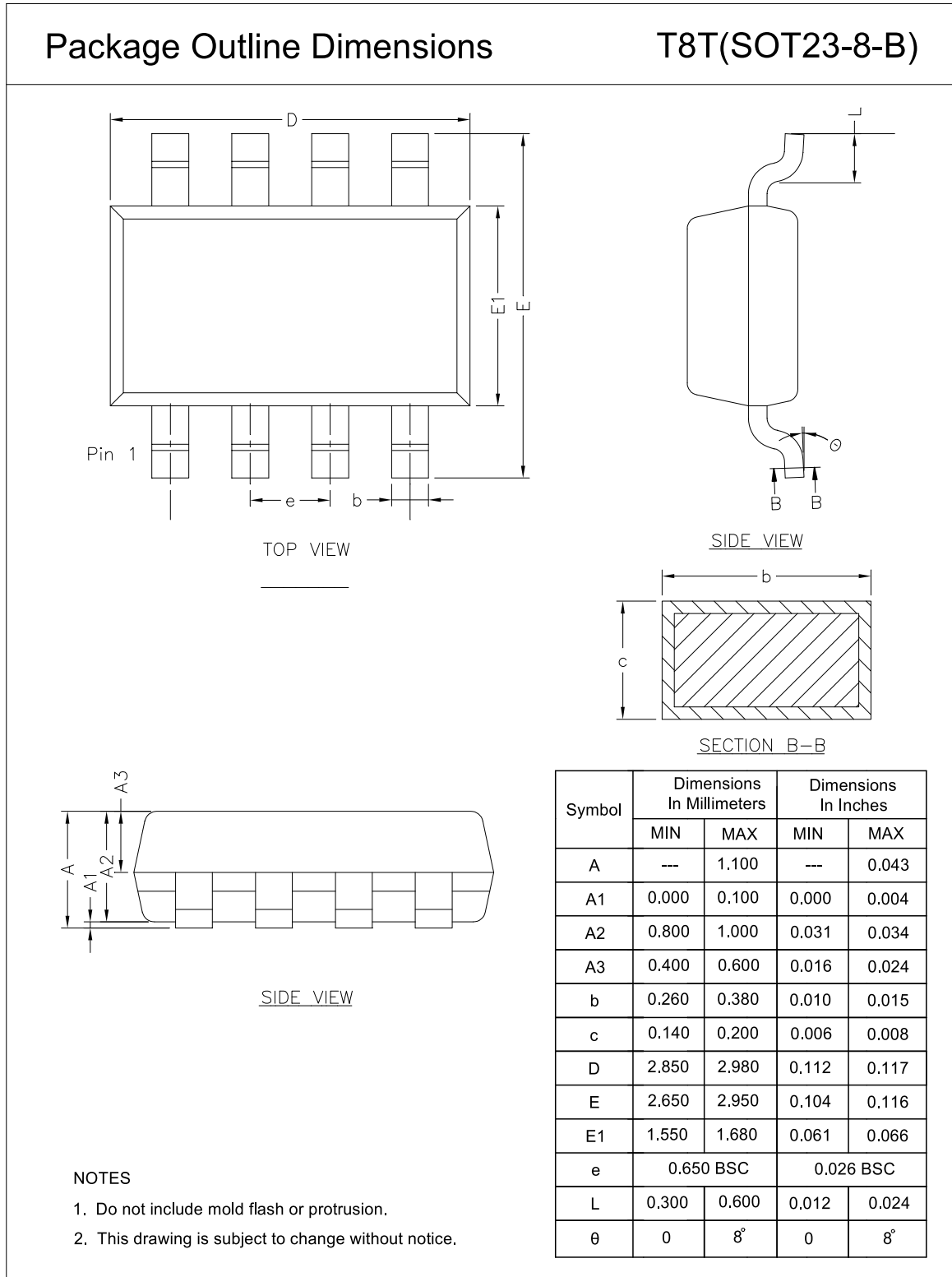

Bidirectional, Current-Sense Amplifier with PWM Rejection
Order Information

Order Number	Gain	Package	Marking Information	MSL	Transport Media, Quantity	Eco Plan
TPA133A0-VS1R-S	10 V/V	MSOP8	133A0	MSL1	Tape and Reel, 3,000	Green
TPA133A1-VS1R-S ⁽¹⁾	20 V/V	MSOP8	133A1	MSL1	Tape and Reel, 3,000	Green
TPA133A2-VS1R-S ⁽¹⁾	50 V/V	MSOP8	133A2	MSL1	Tape and Reel, 3,000	Green
TPA133A3-VS1R-S ⁽¹⁾	100 V/V	MSOP8	133A3	MSL1	Tape and Reel, 3,000	Green
TPA133A4-VS1R-S ⁽¹⁾	200 V/V	MSOP8	133A4	MSL1	Tape and Reel, 3,000	Green
TPA133A5-VS1R-S ⁽¹⁾	500 V/V	MSOP8	133A5	MSL1	Tape and Reel, 3,000	Green
TPA133A0-T8TR-S ⁽¹⁾	10 V/V	SOT23-8	A9N	MSL3	Tape and Reel, 3,000	Green
TPA133A1-T8TR-S	20 V/V	SOT23-8	A98	MSL3	Tape and Reel, 3,000	Green
TPA133A2-T8TR-S ⁽¹⁾	50 V/V	SOT23-8	A9P	MSL3	Tape and Reel, 3,000	Green
TPA133A3-T8TR-S ⁽¹⁾	100 V/V	SOT23-8	A9M	MSL3	Tape and Reel, 3,000	Green
TPA133A4-T8TR-S ⁽¹⁾	200 V/V	SOT23-8	A9Q	MSL3	Tape and Reel, 3,000	Green
TPA133A5-T8TR-S ⁽¹⁾	500 V/V	SOT23-8	A9R	MSL3	Tape and Reel, 3,000	Green

(1) For future products, contact the 3PEAK factory for more information and samples.

Green: 3PEAK defines "Green" to mean RoHS compatible and free of halogen substances.

Bidirectional, Current-Sense Amplifier with PWM Rejection

IMPORTANT NOTICE AND DISCLAIMER

Copyright© 3PEAK 2012-2025. All rights reserved.

Trademarks. Any of the 思瑞浦 or 3PEAK trade names, trademarks, graphic marks, and domain names contained in this document /material are the property of 3PEAK. You may NOT reproduce, modify, publish, transmit or distribute any Trademark without the prior written consent of 3PEAK.

Performance Information. Performance tests or performance range contained in this document/material are either results of design simulation or actual tests conducted under designated testing environment. Any variation in testing environment or simulation environment, including but not limited to testing method, testing process or testing temperature, may affect actual performance of the product.

Disclaimer. 3PEAK provides technical and reliability data (including data sheets), design resources (including reference designs), application or other design recommendations, networking tools, security information and other resources "As Is". 3PEAK makes no warranty as to the absence of defects, and makes no warranties of any kind, express or implied, including without limitation, implied warranties as to merchantability, fitness for a particular purpose or non-infringement of any third-party's intellectual property rights. Unless otherwise specified in writing, products supplied by 3PEAK are not designed to be used in any life-threatening scenarios, including critical medical applications, automotive safety-critical systems, aviation, aerospace, or any situations where failure could result in bodily harm, loss of life, or significant property damage. 3PEAK disclaims all liability for any such unauthorized use.

This page intentionally left blank