

Features

- **Gain-bandwidth Product: 20MHz**
- **Offset Voltage: 50 μ V (max)**
- **Low Noise: 7.3nV/ $\sqrt{\text{Hz}}$ (f= 1kHz)**
- **Slew Rate: 25 V/ μ s**
- **Low THD+N: 0.0005%**
- **Supply Range: 2.2V to 5.5V**
- **Supply Current: 3.5 mA/ch**
- **Low Input Bias Current: 0.3pA Typical**
- **Rail-to-Rail I/O**
- **High Output Current: 70mA (1.0V Drop)**
- **-40°C to 125°C Operation Range**

Applications

- Sensor Signal Conditioning
- Consumer Audio
- Multi-Pole Active Filters
- Control-Loop Amplifiers
- Communications
- Security
- Scanners

Description

The TP2301 series products are very high precision amplifiers featuring very low noise, low offset voltage, high bandwidth, low input bias current and low temperature drift making them the ideal choice for applications requiring both high DC accuracy and AC performance. The combination of precision, low noise, and high bandwidth provides the user with outstanding value and flexibility relative to similar competitive parts.

Applications for these amplifiers include precision active filters, medical and analytical instrumentation, precision power supply controls, and industrial controls requiring high gains. Featuring low THD+N, the TP2301 series is also excellent for consumer audio applications, particularly for single-supply systems.

The TP2301 is single channel version available in 8-pin SOIC and 5-pin SOT23 packages. The TP2302 is dual channel version available in 8-pin SOIC and MSOP packages. The TP2304 is quad channel version available in 14-pin SOP and TSSOP packages.

3PEAK and the 3PEAK logo are registered trademarks of 3PEAK INCORPORATED. All other trademarks are the property of their respective owners.

Pin Configuration (Top View)

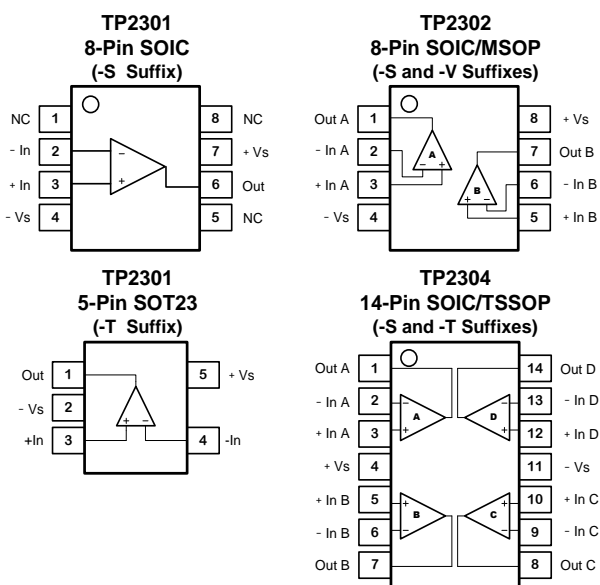

Positive Output Swing vs. Load Current

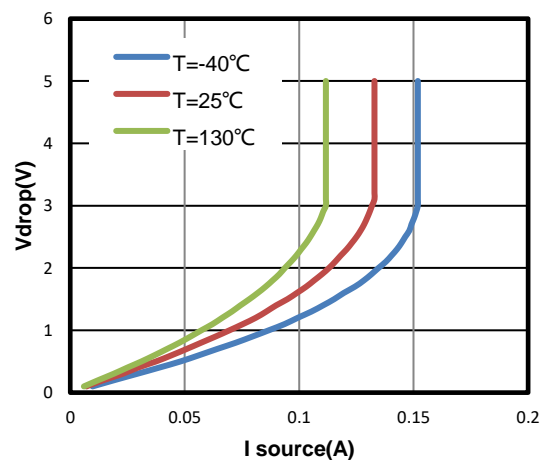

TP2301 / TP2302 / TP2304

20MHz Bandwidth, Low Noise High Precision Op-amps

Order Information

Order Number	Package	MSL	Transport Media, Quantity	Marking Information
TP2301-TR	5-Pin SOT23	MSL3	Tape and Reel, 3,000	301
TP2302-SR	8-Pin SOIC	MSL3	Tape and Reel, 4,000	TP2302
TP2302-VR	8-Pin MSOP	MSL3	Tape and Reel, 3,000	TP2302
TP2304-SR ^{Note 1}	14-Pin SOIC	MSL3	Tape and Reel, 2,500	TP2304
TP2304-TR	14-Pin TSSOP	MSL3	Tape and Reel, 3,000	TP2304

Note 1: Future product, contact 3PEAK factory for more information and sample.

Absolute Maximum Ratings ^{Note 1}

Supply Voltage: $V^+ - V^-$ ^{Note 2}7.0V	Output Short-Circuit Duration ^{Note 4} Infinite
Voltage on Input Pin..... $V^- - 0.3$ to $V^+ + 0.3$	Operating Temperature Range..... -40°C to 125°C
Voltage on Output Pin..... $V^- - 0.3$ to $V^+ + 0.3$	Maximum Junction Temperature..... 150°C
Differential Input Voltage..... $V^- - V^+$ to $V^+ - V^-$	Storage Temperature Range..... -65°C to 150°C
Input Current: +IN, -IN ^{Note 3} $\pm 20\text{mA}$	Lead Temperature (Soldering, 10 sec) 260°C

Note 1: Stresses beyond those listed under Absolute Maximum Ratings may cause permanent damage to the device. Exposure to any Absolute Maximum Rating condition for extended periods may affect device reliability and lifetime.

Note 2: The op amp supplies must be established simultaneously, with, or before, the application of any input signals.

Note 3: The inputs are protected by ESD protection diodes to each power supply. If the input extends more than 500mV beyond the power supply, the input current should be limited to less than 10mA.

Note 4: A heat sink may be required to keep the junction temperature below the absolute maximum. This depends on the power supply voltage and how many amplifiers are shorted. Thermal resistance varies with the amount of PC board metal connected to the package. The specified values are for short traces connected to the leads.

ESD, Electrostatic Discharge Protection

Symbol	Parameter	Condition	Minimum Level	Unit
HBM	Human Body Model ESD	ANSI/ESDA/JEDEC JS-001	4	kV
CDM	Charged Device Model ESD	ANSI/ESDA/JEDEC JS-002	1.5	kV

Thermal Resistance

Package Type	θ_{JA}	θ_{JC}	Unit
5-Pin SOT23	250	81	$^{\circ}\text{C}/\text{W}$
8-Pin SOIC	158	43	$^{\circ}\text{C}/\text{W}$
8-Pin MSOP	210	45	$^{\circ}\text{C}/\text{W}$
14-Pin SOIC	120	36	$^{\circ}\text{C}/\text{W}$
14-Pin TSSOP	180	35	$^{\circ}\text{C}/\text{W}$

20MHz Bandwidth, Low Noise High Precision Op-amps

Electrical Characteristics

The specifications are at $T_A = 27^\circ\text{C}$. $V_S = +2.2\text{ V to }+5.5\text{ V}$, or $\pm 1.1\text{ V to } \pm 2.75\text{ V}$, $R_L = 2\text{ k}\Omega$, $C_L = 100\text{ pF}$. Unless otherwise noted.

SYMBOL	PARAMETER	CONDITIONS	MIN	TYP	MAX	UNITS
V _{OS}	Input Offset Voltage	V _{CM} = V _{DD} /2, TP2301 and TP2302	-50	±7	+50	μV
		V _{CM} = V _{DD} /2, TP2304	-100	±15	+100	μV
V _{OS} TC	Input Offset Voltage Drift	-40°C to 125°C		1	2	μV/°C
I _B	Input Bias Current	T _A = 27 °C		0.3		pA
		T _A = 85 °C		150		pA
		T _A = 125 °C		300		pA
I _{OS}	Input Offset Current			0.001		pA
V _n	Input Voltage Noise	f = 0.1Hz to 10Hz		2.0		μV _{PP}
e _n	Input Voltage Noise Density	f = 1kHz		7.3		nV/√Hz
i _n	Input Current Noise	f = 1kHz		2		fA/√Hz
R _{IN}	Input impedance			10 ¹²		Ω
C _{IN}	Input Capacitance	Differential		7.76		pF
		Common Mode		6.87		
CMRR	Common Mode Rejection Ratio	V _{CM} = 2V to 3V	80	100		dB
V _{CM}	Common-mode Input Voltage Range		(V ⁻) - 0.3		(V ⁺) + 0.3	V
PSRR	Power Supply Rejection Ratio	V _{CM} = 2.5V, V _S = 4V to 5V	80	100		dB
A _{VOL}	Open-Loop Large Signal Gain	R _{LOAD} = 2kΩ	100	130		dB
V _{OL} , V _{OH}	Output Swing from Supply Rail	R _{LOAD} = 2kΩ		20	50	mV
R _{OUT}	Closed-Loop Output Impedance	G = 1, f = 1MHz, I _{OUT} = 0		0.043		Ω
R _O	Open-Loop Output Impedance	f = 1kHz, I _{OUT} = 0		125		Ω
I _{SC}	Output Short-Circuit Current	Sink or source current	100	130	200	mA
V _{DD}	Supply Voltage		2.2		5.5	V
I _Q	Quiescent Current per Amplifier	TP2301, V _{DD} = 5V		5	9	mA
		TP2302/TP2304, V _{DD} = 5V		3.5	5	mA
PM	Phase Margin	R _{LOAD} = 1kΩ, C _{LOAD} = 60pF		60		°
GM	Gain Margin	R _{LOAD} = 1kΩ, C _{LOAD} = 60pF		11		dB
GBWP	Gain-Bandwidth Product	f = 1kHz		20		MHz
SR	Slew Rate	A _V = 1, V _{OUT} = 1.5V to 3.5V, C _{LOAD} = 60pF, R _{LOAD} = 1kΩ	15	25		V/μs
FPBW	Full Power Bandwidth ^{Note 1}			5.21		MHz
t _s	Settling Time, 0.1% Settling Time, 0.01%	A _V = -1, 1V Step		0.29		μs
				0.45		
THD+N	Total Harmonic Distortion and Noise	f = 1kHz, A _V = 1, R _L = 2kΩ, V _{OUT} = 1V _{p-p}		123		dB
X _{talk}	Channel Separation	f = 1kHz, R _L = 2kΩ		110		dB

Note 1: Full power bandwidth is calculated from the slew rate $FPBW = SR/\pi \cdot V_{P-P}$

20MHz Bandwidth, Low Noise High Precision Op-amps Typical Performance Characteristics

$V_S = \pm 2.5V$, $V_{CM} = 0V$, $R_L = \text{Open}$, unless otherwise specified.

Offset Voltage Production Distribution

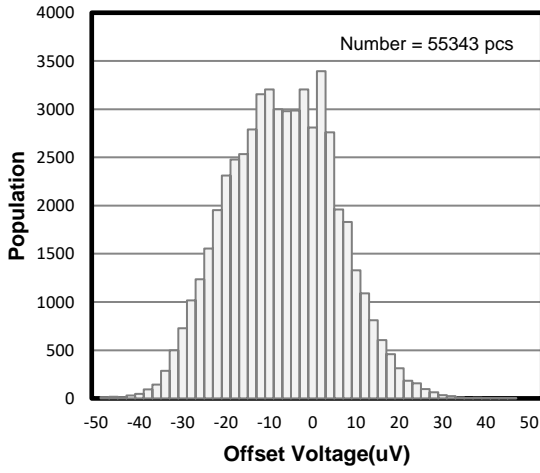

CMRR vs. Temperature

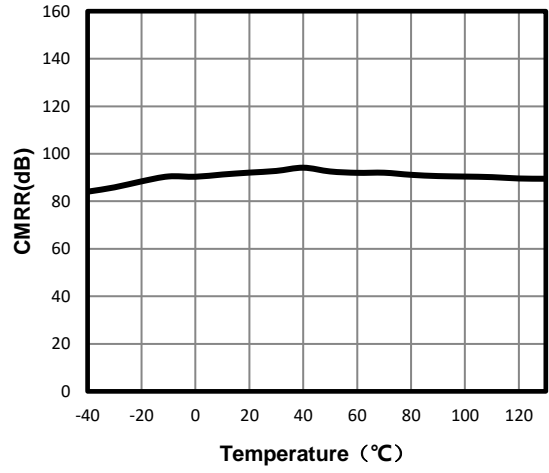

Open-Loop Gain and Phase

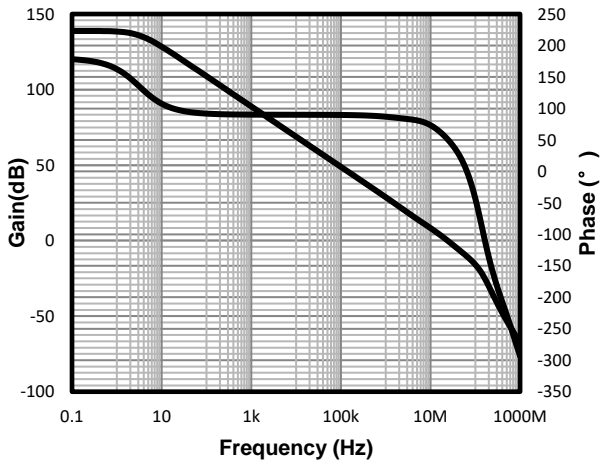

Input Voltage Noise Spectral Density

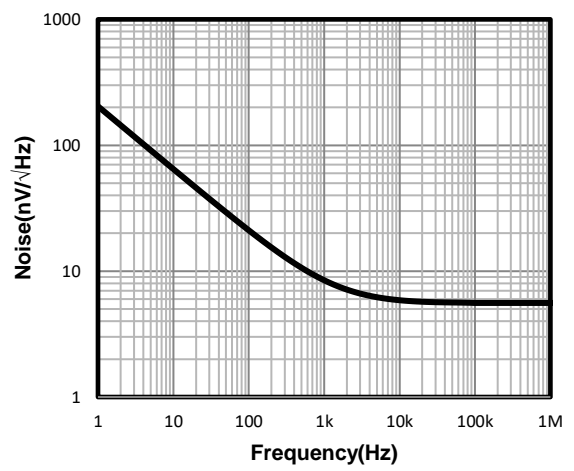

20MHz Bandwidth, Low Noise High Precision Op-amps

Typical Performance Characteristics

$V_S = \pm 2.5V$, $V_{CM} = 0V$, $R_L = \text{Open}$, unless otherwise specified. (Continued)

Common Mode Rejection Ratio

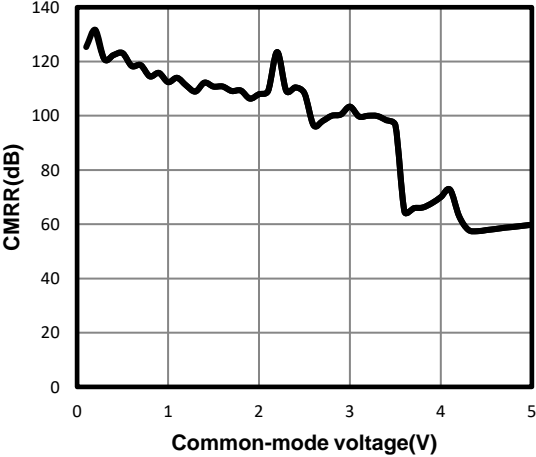

CMRR vs. Frequency

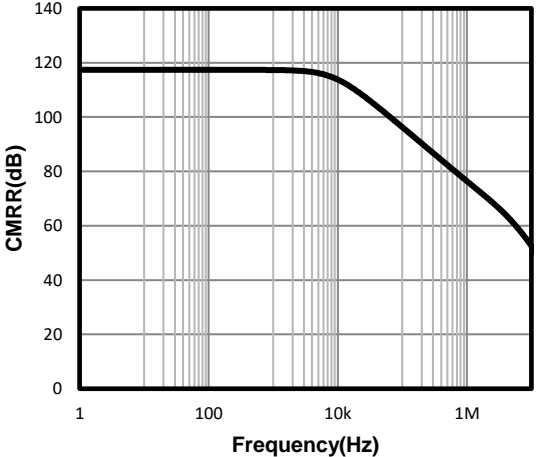

Quiescent Current vs. Temperature

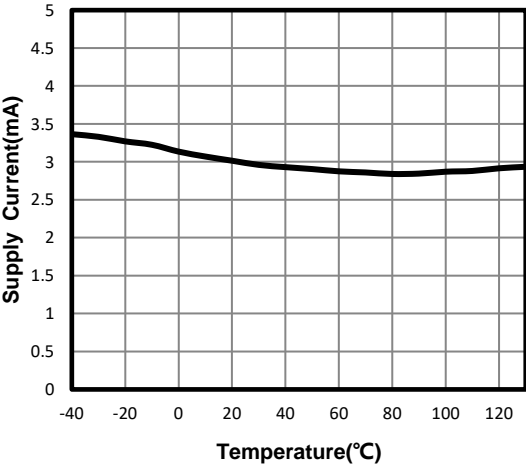

Short Circuit Current vs. Temperature

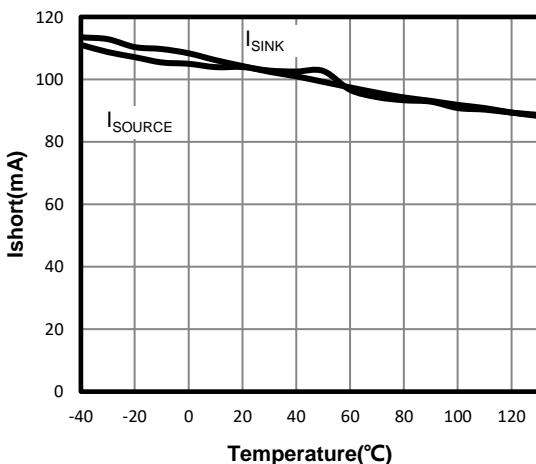

Power-Supply Rejection Ratio

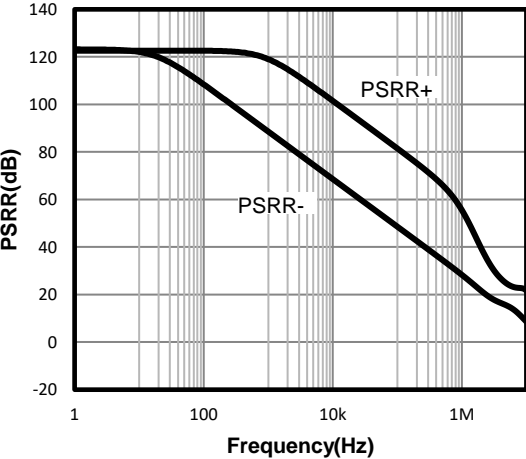

Quiescent Current vs. Supply Voltage

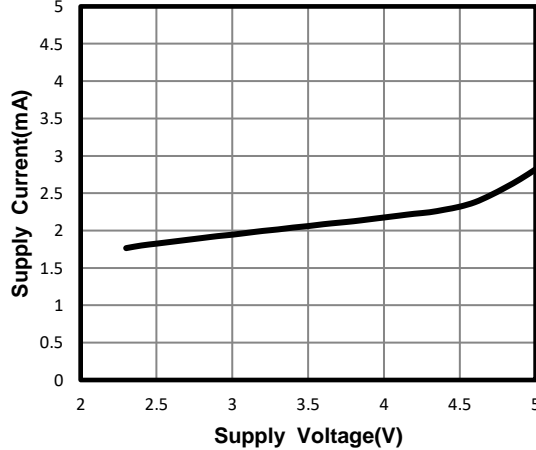

20MHz Bandwidth, Low Noise High Precision Op-amps
Typical Performance Characteristics

$V_S = \pm 2.5V$, $V_{CM} = 0V$, $R_L = \text{Open}$, unless otherwise specified. (Continued)

Power-Supply Rejection Ratio vs. Temperature

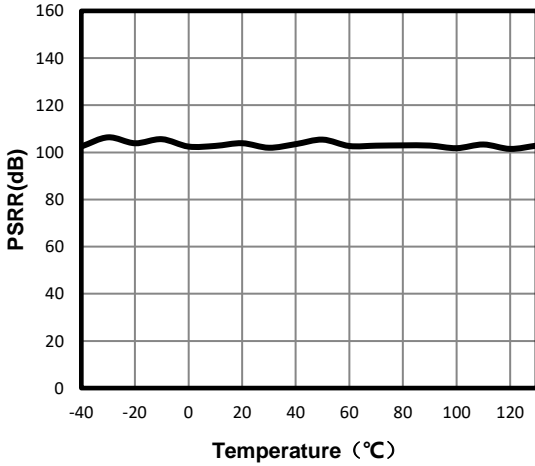

CMRR vs. Temperature

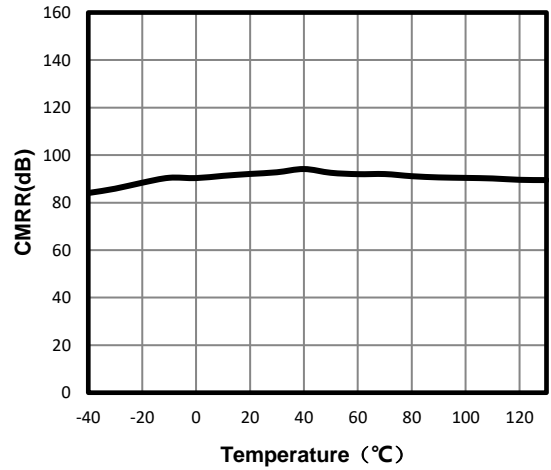

EMIRR IN+ vs. Frequency

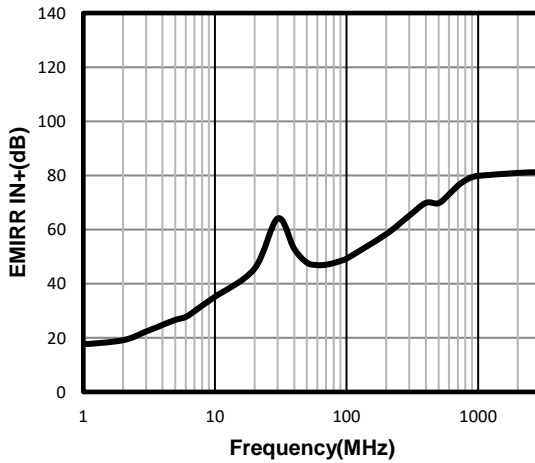

Large-Scale Step Response

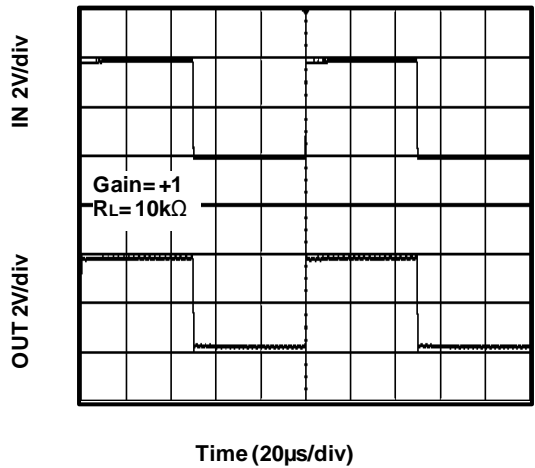

Negative Over-Voltage Recovery

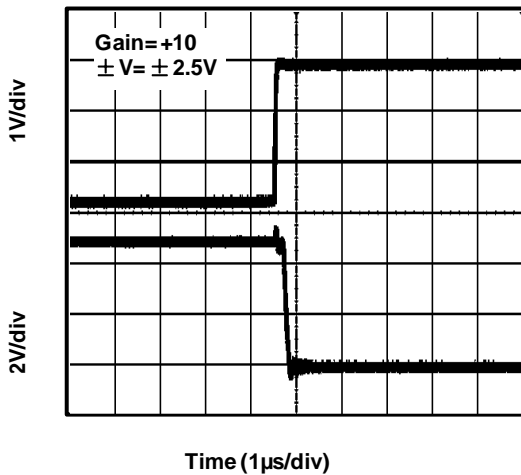

Positive Over-Voltage Recovery

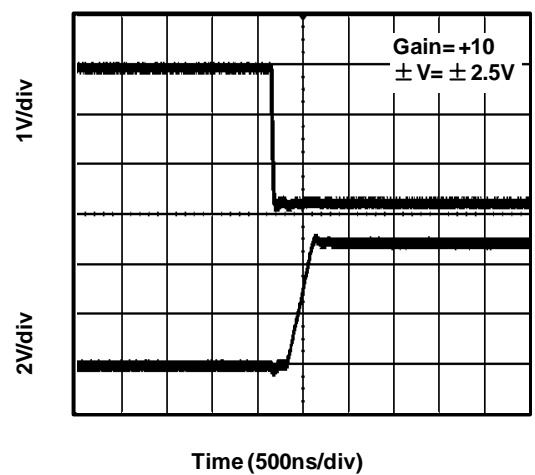

20MHz Bandwidth, Low Noise High Precision Op-amps

Typical Performance Characteristics

V_S = ±2.5V, V_{CM} = 0V, R_L = Open, unless otherwise specified. (Continued)

Negative Output Swing vs. Load Current

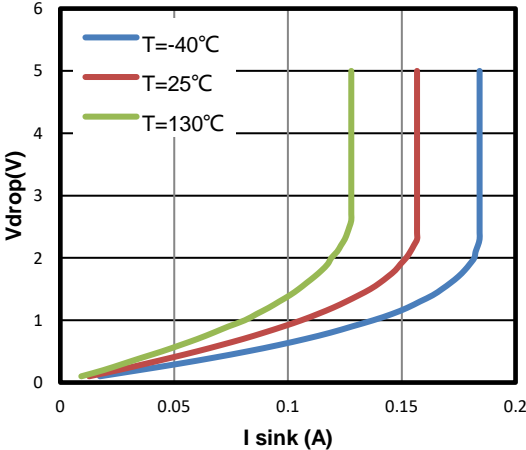

Offset Voltage vs Common-Mode Voltage

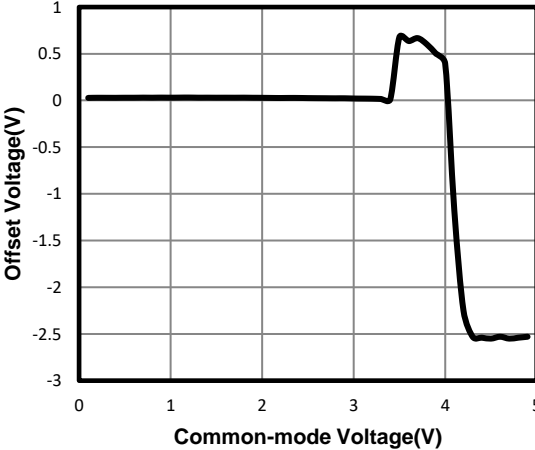

Positive Output Swing vs. Load Current

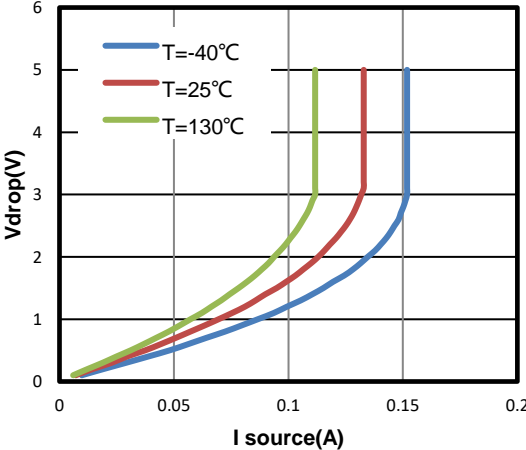

TP2301 / TP2302 / TP2304

20MHz Bandwidth, Low Noise High Precision Op-amps

Tape and Reel Information

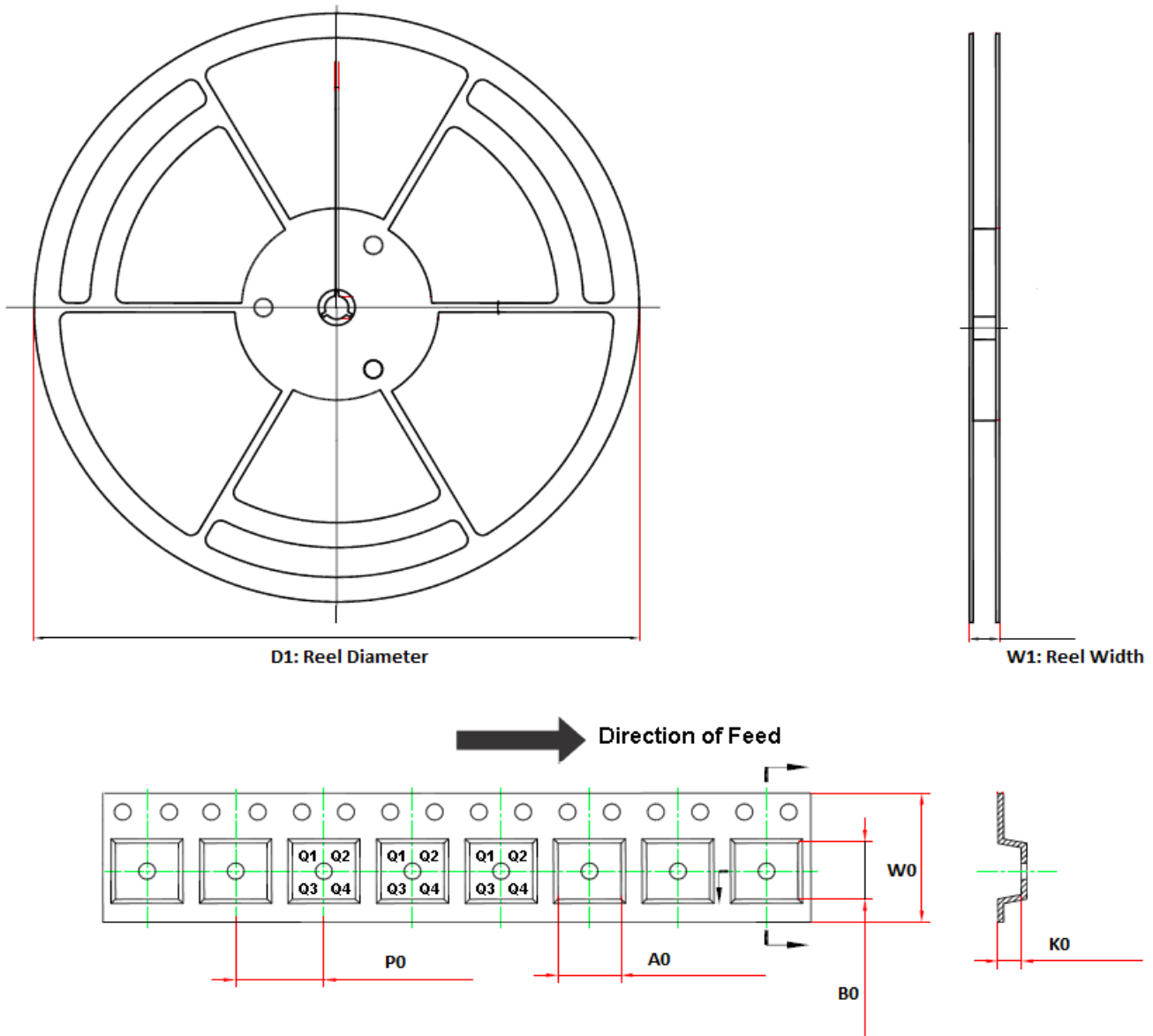

Order Number	Package	D1	W1	A0	B0	K0	P0	W0	Pin1 Quadrant
TP2301-TR	SOT23-5	179.0	12.0	3.3	3.25	1.4	4.0	8.0	Q3
TP2302-SR	SOP8	330.0	17.6	6.5	5.4	2.0	8.0	12.0	Q1
TP2302-VR	MSOP8	330.0	17.6	5.2	3.3	1.5	8.0	12.0	Q1
TP2304-SR	SOP14	330.0	21.6	6.5	9.1	1.9	8.0	16.0	Q1
TP2304-TR	TSSOP14	330.0	17.6	6.8	5.5	1.7	8.0	12.0	Q1

Package Outline Dimensions

SOT23-5

Package Outline Dimensions

S5T(SOT23-5-A)

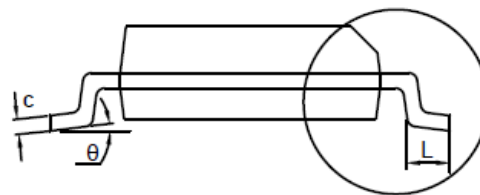
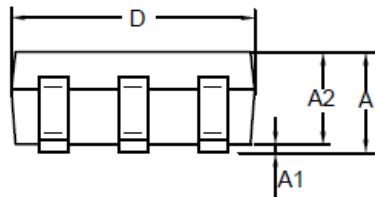
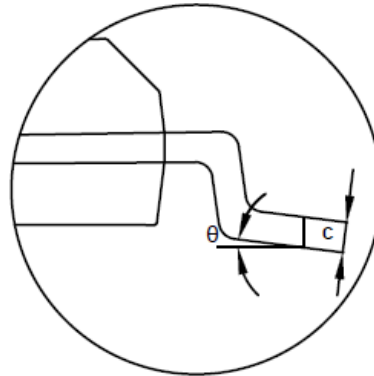
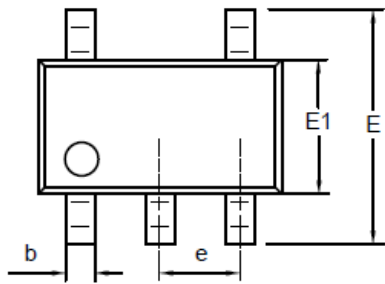

Symbol	Dimensions In Millimeters		Dimensions In Inches	
	MIN	MAX	MIN	MAX
A	1.050	1.250	0.041	0.049
A1	0.000	0.150	0.000	0.006
A2	1.000	1.200	0.039	0.047
b	0.280	0.500	0.011	0.020
c	0.100	0.230	0.004	0.009
D	2.820	3.020	0.111	0.119
E	2.600	3.000	0.102	0.118
E1	1.500	1.720	0.059	0.068
e	0.950 BSC		0.037 BSC	
L	0.300	0.600	0.012	0.024
θ	0	8°	0	8°

NOTES

1. Do not include mold flash or protrusion.
2. This drawing is subject to change without notice.

Package Outline Dimensions

SO1(SOP-8-A)

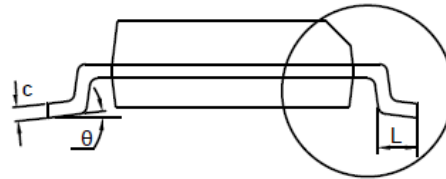
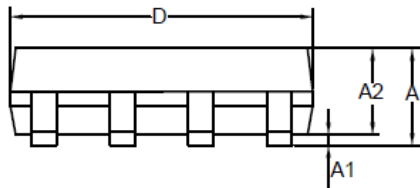
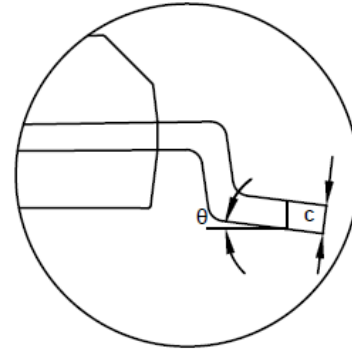
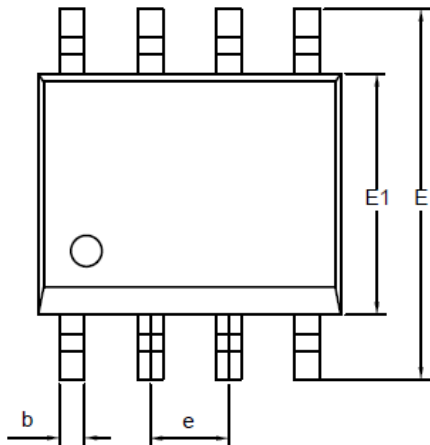

Symbol	Dimensions In Millimeters		Dimensions In Inches	
	MIN	MAX	MIN	MAX
A	1.350	1.750	0.053	0.069
A1	0.050	0.250	0.002	0.010
A2	1.250	1.550	0.049	0.061
b	0.330	0.510	0.013	0.020
c	0.170	0.250	0.007	0.010
D	4.700	5.100	0.185	0.201
E	5.800	6.200	0.228	0.244
E1	3.800	4.000	0.150	0.157
e	1.270 BSC		0.050 BSC	
L	0.400	1.000	0.016	0.039
θ	0	8	0	8

NOTES

1. Do not include mold flash or protrusion.
2. This drawing is subject to change without notice.

TSSOP8

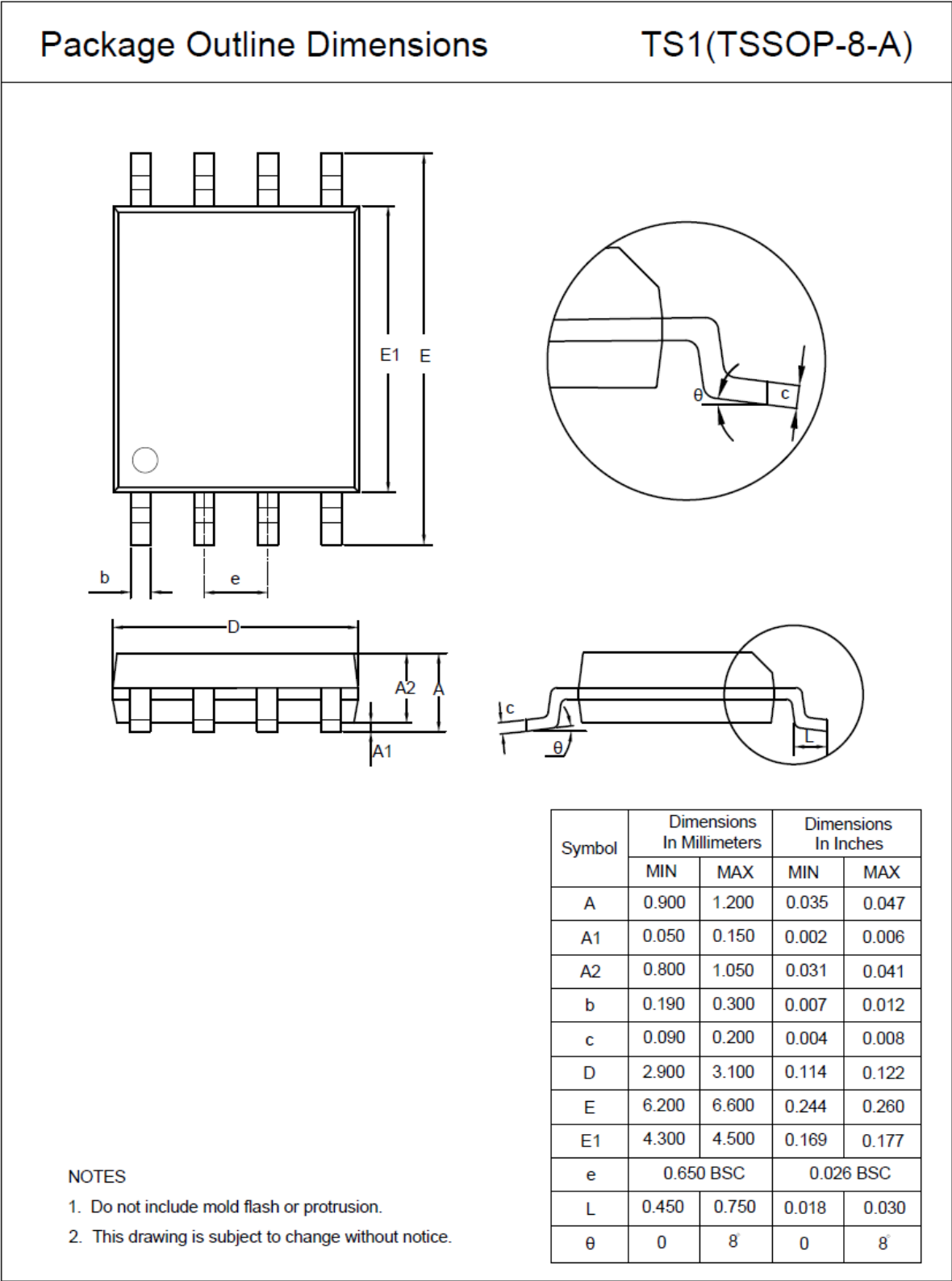

Package Outline Dimensions

VS1(MSOP-8-A)

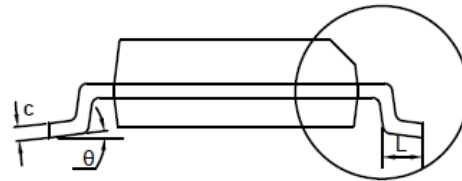
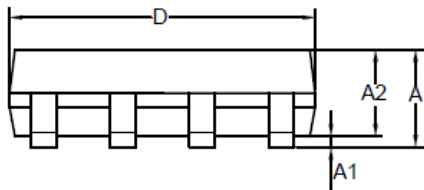
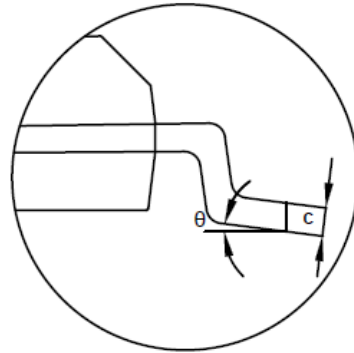
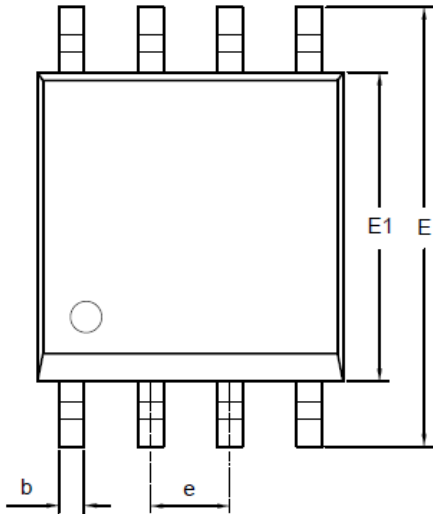

Symbol	Dimensions In Millimeters		Dimensions In Inches	
	MIN	MAX	MIN	MAX
A	0.800	1.100	0.031	0.043
A1	0.050	0.150	0.002	0.006
A2	0.750	0.950	0.030	0.037
b	0.250	0.380	0.010	0.015
c	0.090	0.230	0.004	0.009
D	2.900	3.100	0.114	0.122
E	4.700	5.100	0.185	0.201
E1	2.900	3.100	0.114	0.122
e	0.650 BSC		0.026 BSC	
L	0.400	0.800	0.016	0.031
θ	0	8°	0	8°

NOTES

1. Do not include mold flash or protrusion.
2. This drawing is subject to change without notice.

SOP14

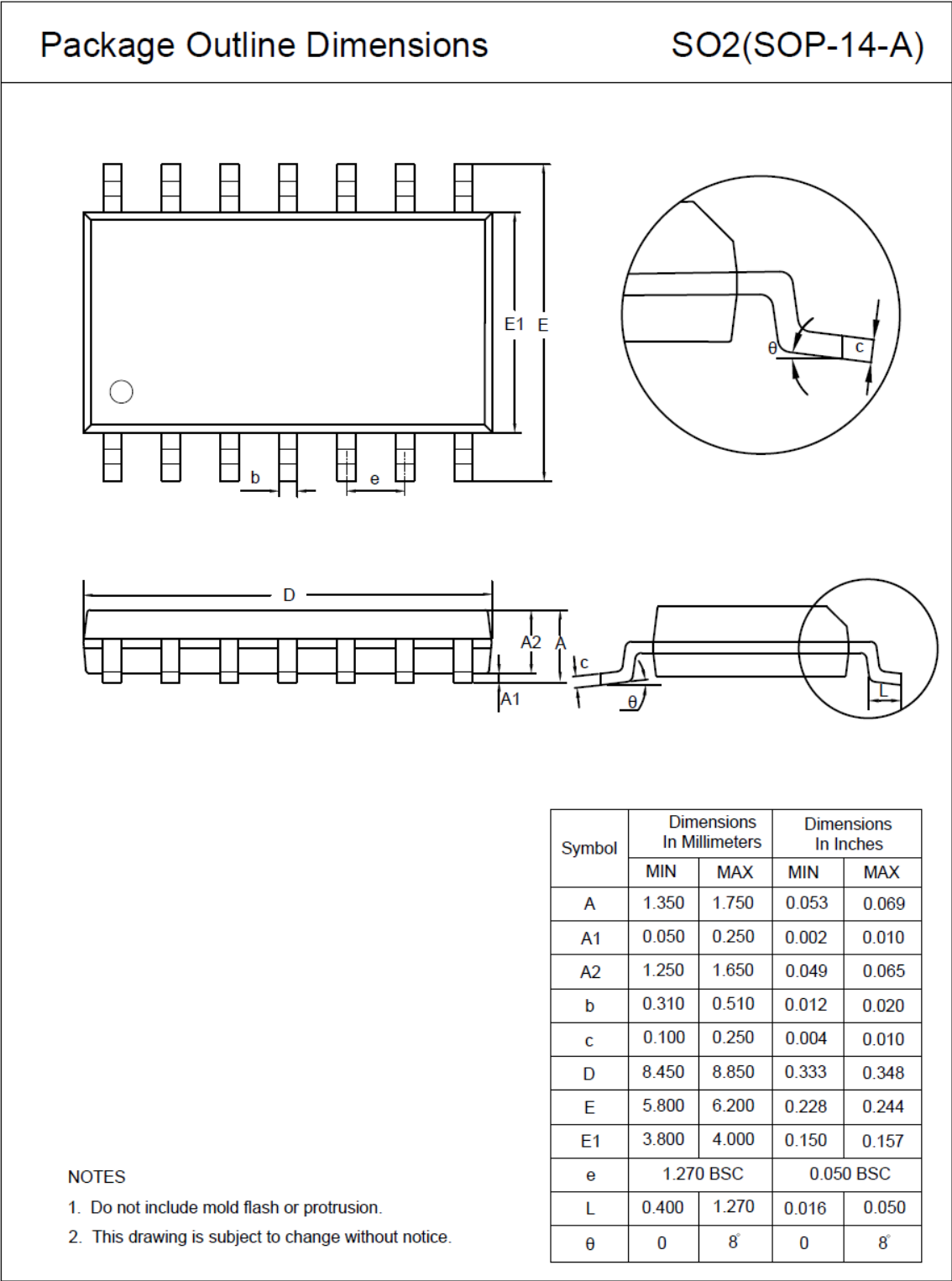

Package Outline Dimensions

TS2(TSSOP-14-A)

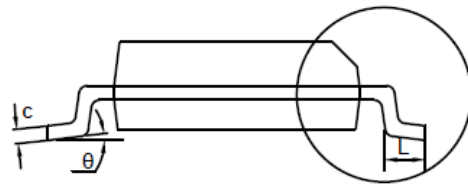
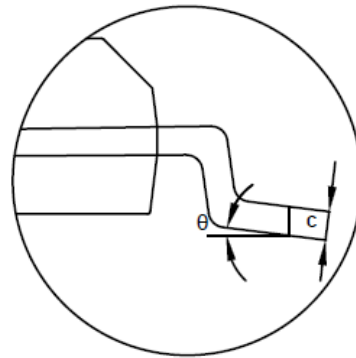
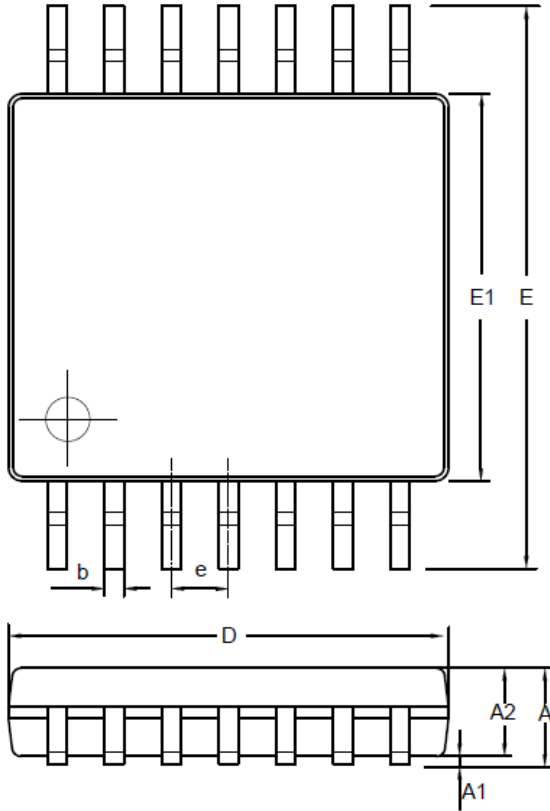

Symbol	Dimensions In Millimeters		Dimensions In Inches	
	MIN	MAX	MIN	MAX
A	0.900	1.200	0.035	0.047
A1	0.050	0.150	0.002	0.006
A2	0.800	1.050	0.031	0.041
b	0.190	0.300	0.007	0.012
c	0.090	0.200	0.004	0.008
D	4.900	5.100	0.193	0.201
E	6.200	6.600	0.244	0.260
E1	4.300	4.500	0.169	0.177
e	0.650 BSC		0.026 BSC	
L	0.450	0.750	0.018	0.030
theta	0	8°	0	8°

NOTES

1. Do not include mold flash or protrusion.
2. This drawing is subject to change without notice.

Revision History

Date	Revision	Notes
2022/4/29	A.4	Update order information. Update EC table: VOL/VOH: typ 13mV -> 20mV; max 20mV -> 50mV Iq of TP2301(1ch): typ 5mA, max 9mA Slew Rate: min 18 -> 15
2023/5/29	A.5	The following updates are all about the new datasheet formats or typo, the actual product remains unchanged. Updated to new format of package dimensions and tape and reel information. Updated Absolute Maximum Ratings, added differential input voltage. Updated address of web site. Updated the HBM value from 6kV to 4kV, CDM value from 2kV to 1.5kV due to new test standard.

IMPORTANT NOTICE AND DISCLAIMER

Copyright© 3PEAK 2012-2023. All rights reserved.

Trademarks. Any of the 思瑞浦 or 3PEAK trade names, trademarks, graphic marks, and domain names contained in this document /material are the property of 3PEAK. You may NOT reproduce, modify, publish, transmit or distribute any Trademark without the prior written consent of 3PEAK.

Performance Information. Performance tests or performance range contained in this document/material are either results of design simulation or actual tests conducted under designated testing environment. Any variation in testing environment or simulation environment, including but not limited to testing method, testing process or testing temperature, may affect actual performance of the product.

Disclaimer. 3PEAK provides technical and reliability data (including data sheets), design resources (including reference designs), application or other design recommendations, networking tools, security information and other resources "As Is". 3PEAK makes no warranty as to the absence of defects, and makes no warranties of any kind, express or implied, including without limitation, implied warranties as to merchantability, fitness for a particular purpose or non-infringement of any third-party's intellectual property rights. Unless otherwise specified in writing, products supplied by 3PEAK are not designed to be used in any life-threatening scenarios, including critical medical applications, automotive safety-critical systems, aviation, aerospace, or any situations where failure could result in bodily harm, loss of life, or significant property damage. 3PEAK disclaims all liability for any such unauthorized use.