

Features

- Ultra-Low Supply Current: 200 nA per channel
- Fast Response Time: 13 μ s Propagation Delay, with 100 mV Overdrive
- Internal Hysteresis for Clean Switching
- Offset Voltage: ± 12.0 mV Maximum
- Input Bias Current: 6 pA Typical
- No Phase Reversal for Overdriven Inputs
- Low Supply Voltage: 1.6V to 6V

Applications

- Battery Monitoring / Management
- Alarm and Monitoring Circuits
- Peak and Zero-crossing Detectors
- Threshold Detectors/Discriminators
- Sensing at Ground or Supply Line
- Logic Level Shifting or Translation
- Window Comparators
- Oscillators and RC Timers
- Mobile Communications and Notebooks
- Ultra-Low-Power Systems

Descriptions

The TP201x family of push-pull output comparators features the world-class lowest nano-power (250nA maximum) and fast 13 μ s response time capability, allowing operation from 1.6V to 6V. Input common-mode range to supply rails makes the TP201x an ideal choice for power-sensitive, low-voltage (2-cell) applications.

The TP201x push-pull output supports rail-to-rail output swing and interfaces with TTL /CMOS logic, and are capable of driving heavy DC or capacitive loads. The internal input hysteresis eliminates output switching due to internal input noise voltage, reducing current draw. The output limits supply current surges and dynamic power consumption while switching. Beyond the rails input and rail-to-rail output characteristics allow the full power-supply voltage to be used for signal range.

3PEAK and the 3PEAK logo are registered trademarks of 3PEAK Incorporated. All other trademarks are the property of their respective owners.

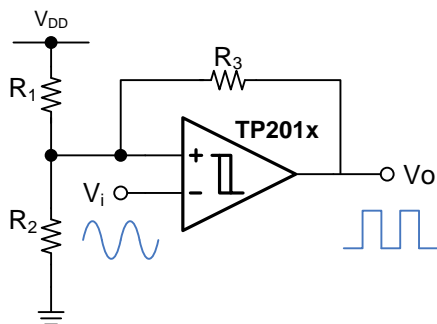

Typical Application of TP201x Comparators

TP2011/TP2012/TP2014

Ultra-Low Power 200nA, 1.6V, RRIO, Push-Pull Output Comparators

Pin Configuration (Top View)

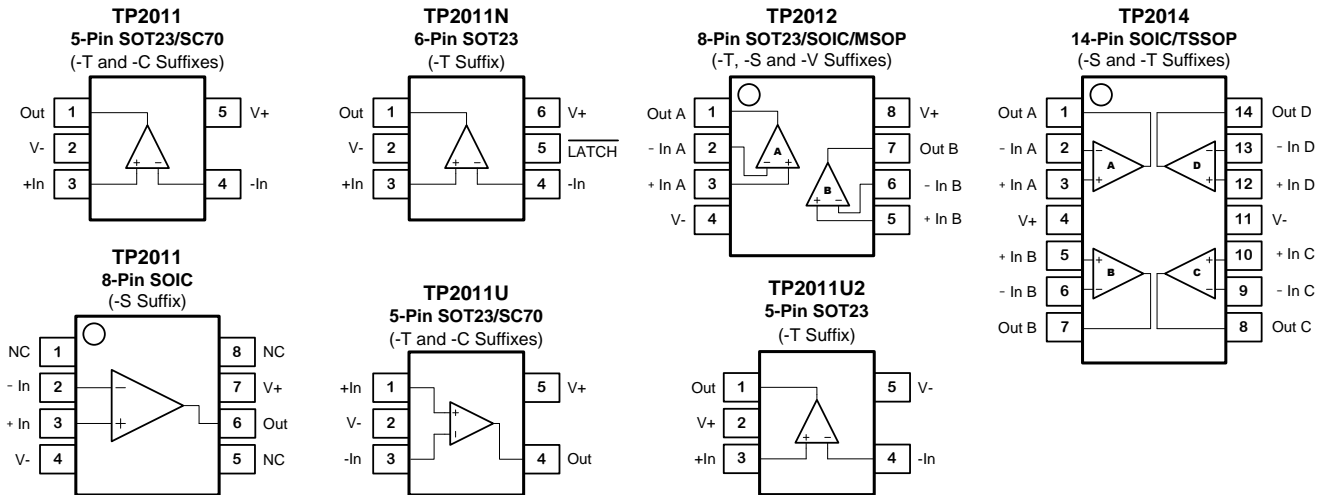

Order Information

Model Name	Order Number	Package	Transport Media, Quantity	Marking Information
TP2011	TP2011-TR	5-Pin SOT23	Tape and Reel, 3000	C1T
	TP2011-CR	5-Pin SC70	Tape and Reel, 3000	C1C
TP2011U	TP2011U -TR	5-Pin SOT23	Tape and Reel, 3000	C1A
TP2011U2	TP2011U2L1-TR	5-Pin SOT23	Tape and Reel, 3000	C1E
TP2012	TP2012-SR	8-Pin SOIC	Tape and Reel, 4000	2012S
	TP2012-VR	8-Pin MSOP	Tape and Reel, 3000	2012V

Pin Functions

N/C: No Connection.

-IN: Inverting Input of the Comparator. Voltage range of this pin can go from $V^- - 0.3V$ to $V^+ + 0.3V$.

+IN: Non-Inverting Input of Comparator. This pin has the same voltage range as -IN.

V+ (V_{DD}): Positive Power Supply. Typically the voltage is from 1.6V to 6V. Split supplies are possible as long as the voltage between V+ and V- is between 1.6V and 6V. A bypass capacitor of 0.1μF as close to the part as possible should be used between power supply pins or between supply pins and ground.

V- (V_{SS}): Negative Power Supply. It is normally tied to ground. It can also be tied to a voltage other than ground as long as the voltage between V+ and V- is from 1.6V to 6V. If it is not connected to ground, bypass it with a capacitor of 0.1μF as close to the part as possible.

OUT: Comparator Output. The voltage range extends to within millivolts of each supply rail.

LATCH: Active **Low** Latch enable. Latch enable threshold is $1/2V^+$ above negative supply rail.

Absolute Maximum Ratings Note 1

Supply Voltage: $V^+ - V^-$6.5V	Operating Temperature Range.....-40°C to 85°C
Input Voltage..... $V^- - 0.3$ to $V^+ + 0.3$	Maximum Junction Temperature..... 150°C
Input Current: +IN, -IN, <small>Note 2</small>±10mA	Storage Temperature Range..... -65°C to 150°C
Output Current: OUT..... ±25mA	Lead Temperature (Soldering, 10 sec) 260°C
Output Short-Circuit Duration <small>Note 3</small> Indefinite	

Note 1: Stresses beyond those listed under Absolute Maximum Ratings may cause permanent damage to the device. Exposure to any Absolute Maximum Rating condition for extended periods may affect device reliability and lifetime.

Note 2: The inputs are protected by ESD protection diodes to each power supply. If the input extends more than 500mV beyond the power supply, the input current should be limited to less than 10mA.

Note 3: A heat sink may be required to keep the junction temperature below the absolute maximum. This depends on the power supply voltage and how many amplifiers are shorted. Thermal resistance varies with the amount of PC board metal connected to the package. The specified values are for short traces connected to the leads.

ESD, Electrostatic Discharge Protection

Symbol	Parameter	Condition	Minimum Level	Unit
HBM	Human Body Model ESD	ANSI/ESDA/JEDEC JS-001	2	kV
CDM	Charged Device Model ESD	ANSI/ESDA/JEDEC JS-002	1	kV

Thermal Information

Package	$R_{\theta JA}$	$R_{\theta JC(TOP)}$	Unit
8-Pin SOP	112.4	64.1	°C/W
14-Pin SOP	96.7	46.7	°C/W
14-Pin TSSOP	108.1	42.7	°C/W

Electrical Characteristics

The ● denotes the specifications which apply over the full operating temperature range, otherwise specifications are at $T_A = 27^\circ\text{C}$. $V_{DD} = 5\text{V}$, $V_{IN+} = V_{DD}$, $V_{IN-} = 1.2\text{V}$, $C_L = 15\text{pF}$.

SYMBOL	PARAMETER	CONDITIONS	MIN	TYP	MAX	UNITS
V_{DD}	Supply Voltage		● 1.6		6	V
V_{OS}	Input Offset Voltage ^{Note 1}	$V_{CM} = 1.2\text{V}$	-12.0	0.5	+12.0	mV
V_{OS}	Input Offset Voltage ^{Note 1}	$V_{CM} = 0\text{V}$	-12.0	0.5	+12.0	mV
V_{OS}	Input Offset Voltage ^{Note 1}	$V_{CM} = 3.8\text{V}$	-12.0	0.5	+12.0	mV
$V_{OS\ TC}$	Input Offset Voltage Drift ^{Note 1}	$V_{CM} = 1.2\text{V}$		0.3		$\mu\text{V}/^\circ\text{C}$
V_{HYST}	Input Hysteresis Voltage ^{Note 1}	$V_{CM} = 1.2\text{V}$		4		mV
I_B	Input Bias Current	$V_{CM} = 1.2\text{V}$		6		pA
I_{OS}	Input Offset Current	$V_{CM} = 1.2\text{V}$		4		pA
R_{IN}	Input Resistance			> 100		G Ω
C_{IN}	Input Capacitance	Differential Common Mode		2 4		pF
CMRR	Common Mode Rejection Ratio	$V_{CM} = V_{SS}$ to $V_{DD} - 1.2\text{V}$		82		dB
V_{CM}	Common-mode Input Voltage Range ^{Note 3}		● V^-		$V^+ - 1.2$	V
PSRR	Power Supply Rejection Ratio			90		dB
V_{OH}	High-Level Output Voltage	$I_{OUT} = -1\text{mA}$	● $V_{DD} - 0.3$			V
V_{OL}	Low-Level Output Voltage	$I_{OUT} = 1\text{mA}$	●		$V_{SS} + 0.3$	V
I_{SC}	Output Short-Circuit Current	Sink or source current		25		mA
I_Q	Single channel Quiescent Current		90	300	450	nA
	Dual channel Quiescent Current		140	400	550	nA
t_R	Rising Time			5		ns
t_F	Falling Time			5		ns
t_{PD+}	Propagation Delay (Low-to-High)	Overdrive=100mV, $V_{IN-} = 1.2\text{V}$		13		μs
t_{PD-}	Propagation Delay (High-to-Low)	Overdrive=100mV, $V_{IN-} = 1.2\text{V}$		14		μs
$t_{PD-SKEW}$	Propagation Delay Skew ^{Note 2}	Overdrive=100mV, $V_{IN-} = 1.2\text{V}$		1		μs

Note 1: The input offset voltage is the average of the input-referred trip points. The input hysteresis is the difference between the input-referred trip points.

Note 2: Propagation Delay Skew is defined as: $t_{PDSKEW} = t_{PD+} - t_{PD-}$.

Note 3: V_{CM} can be as high as 1.3V when V_{DD} is 2.2V and higher, and temperature is as high as 75 degree.

Typical Performance Characteristics

Input Offset Voltage vs. Temperature

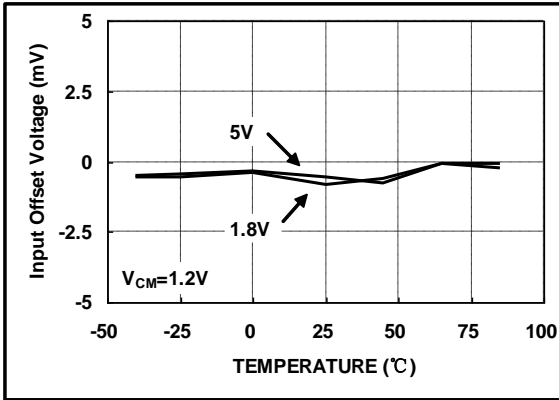

Input Hysteresis Voltage vs. Temperature

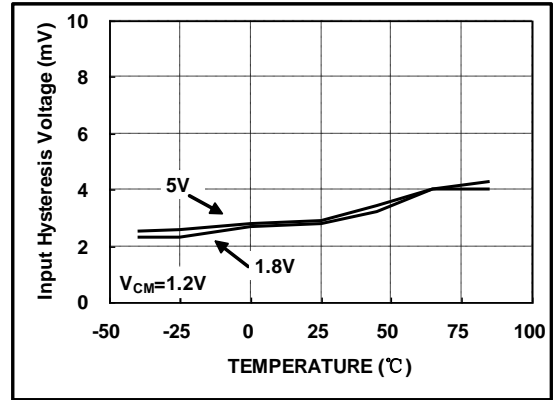

Quiescent Current vs. Temperature

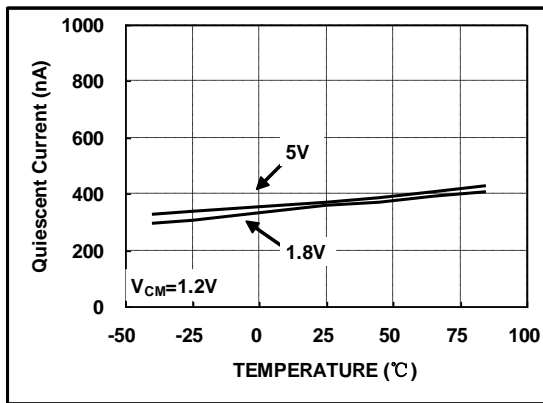

Propagation Delay vs. Temperature

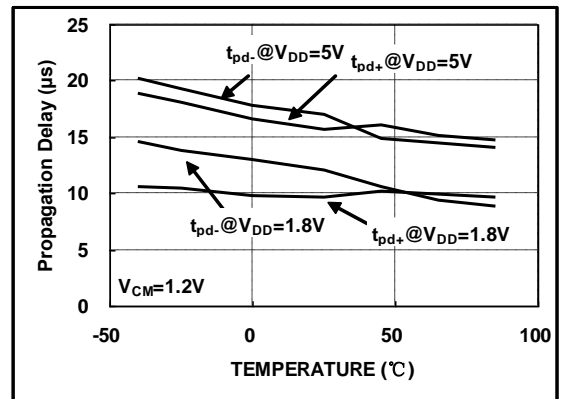

Propagation Delay Skew vs. Temperature

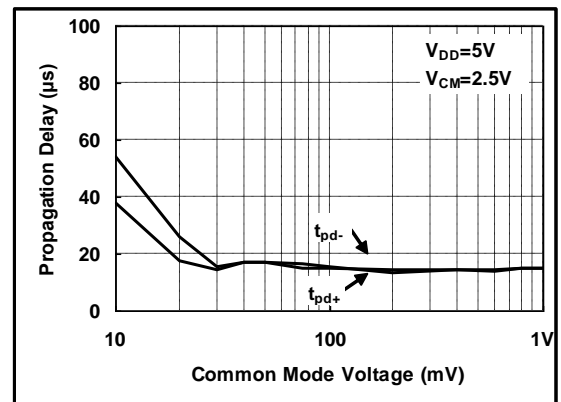
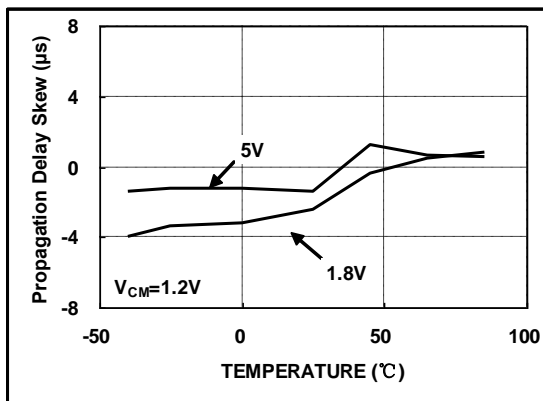

Propagation Delay vs. Overdrive Voltage

Typical Performance Characteristics

Propagation Delay Skew vs. Overdrive Voltage

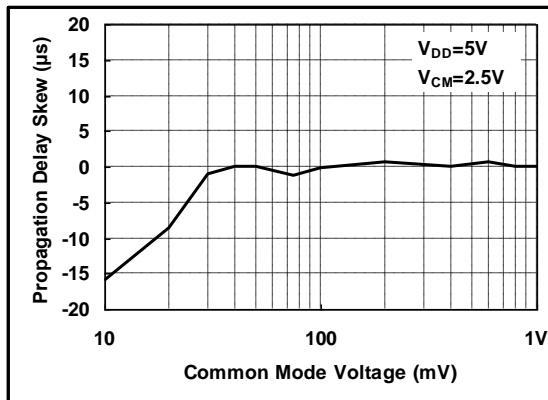

Propagation Delay vs. Overdrive Voltage

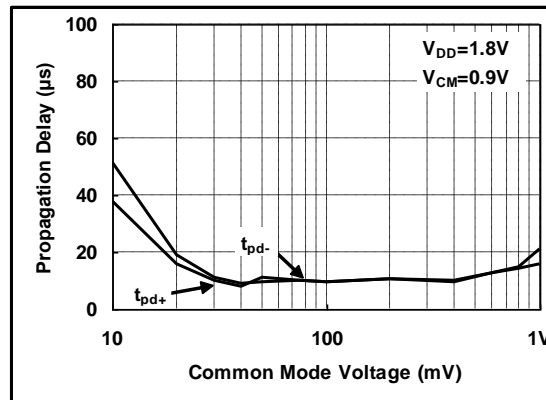

Propagation Delay Skew vs. Overdrive Voltage

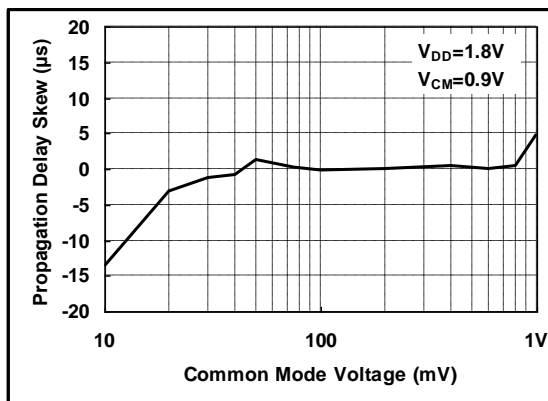

Input Offset Voltage vs. Common Mode Voltage

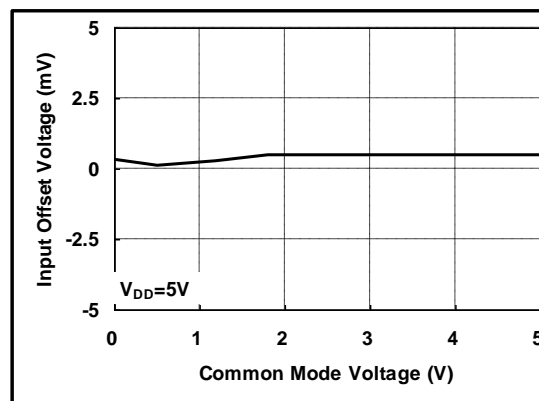

Input Offset Voltage vs. Common Mode Voltage

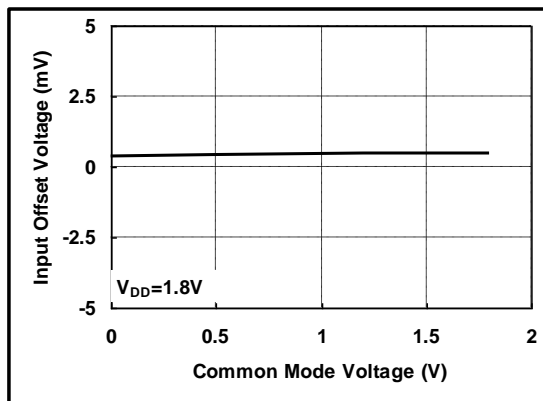

Input Hysteresis Voltage vs. Common Mode Voltage

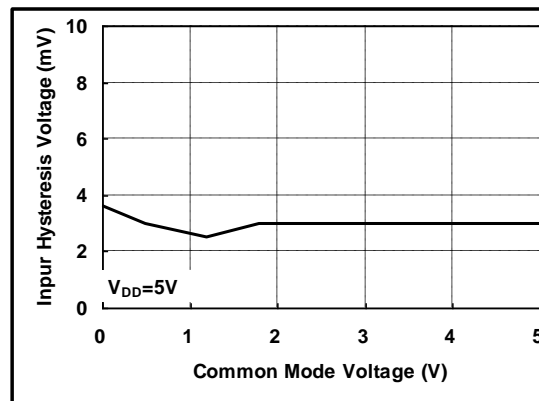

Typical Performance Characteristics

Input Hysteresis Voltage vs. Common Mode Voltage

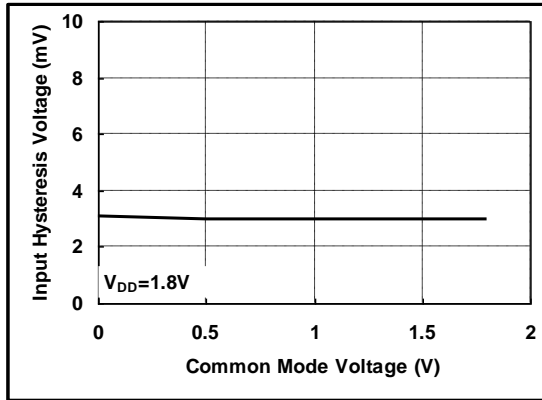

Quiescent Current vs. Common Mode Voltage

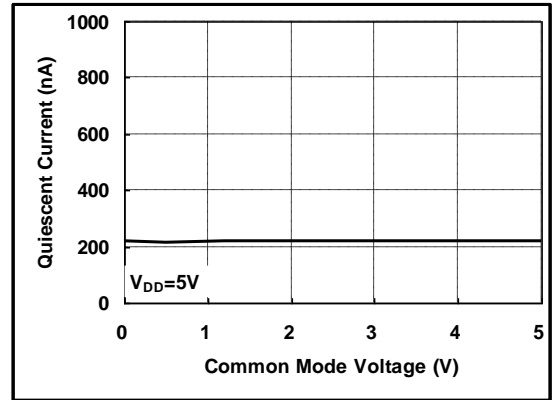

Quiescent Current vs. Common Mode Voltage

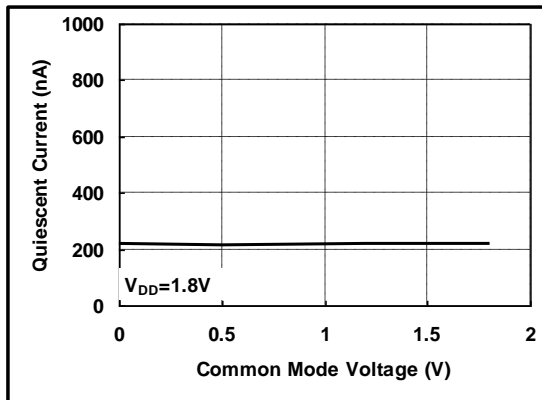

Propagation Delay V.S. Common Mode Voltage

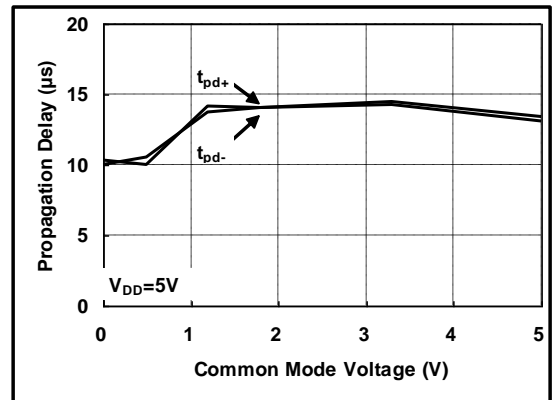

Propagation Delay vs. Common Mode Voltage

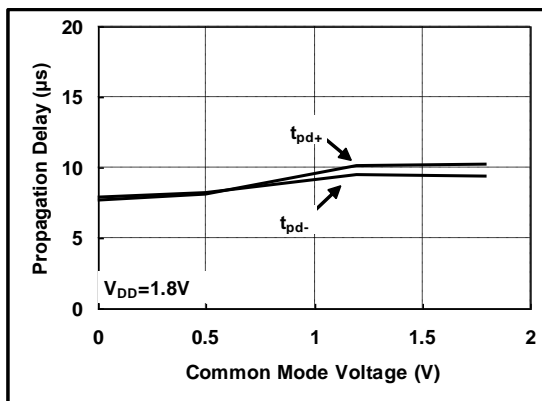

Propagation Delay Skew vs. Common Mode Voltage

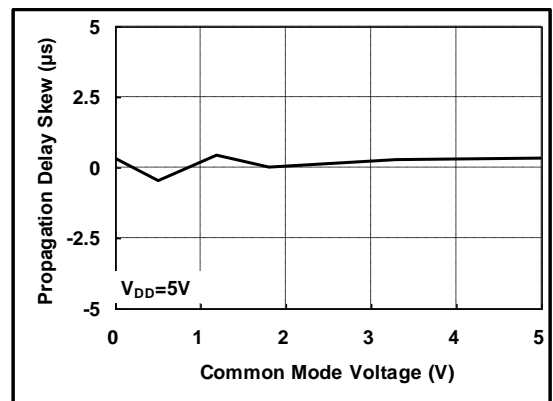

Typical Performance Characteristics

Propagation Delay Skew vs. Common Mode Voltage

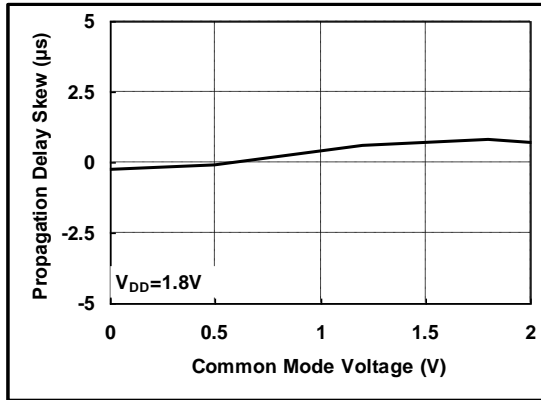

Input Offset Voltage Distribution

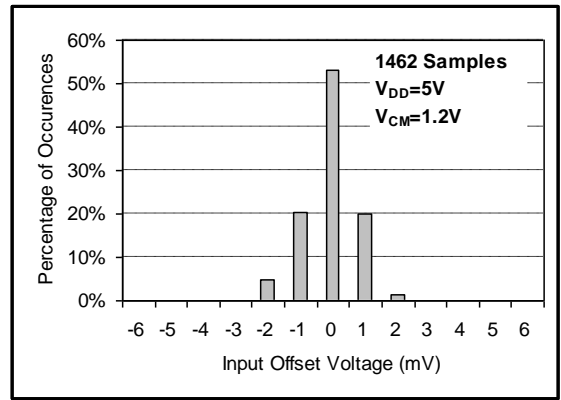

Input Hysteresis Voltage Distribution

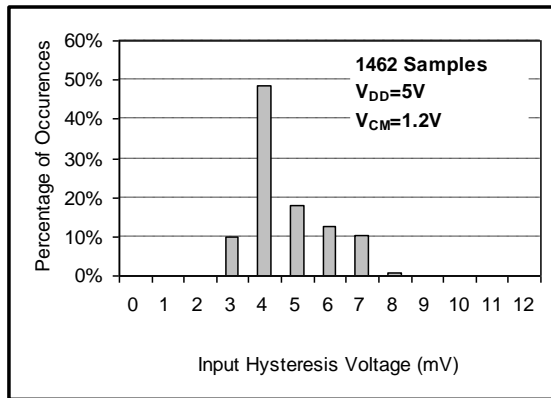

Quiescent Current Distribution

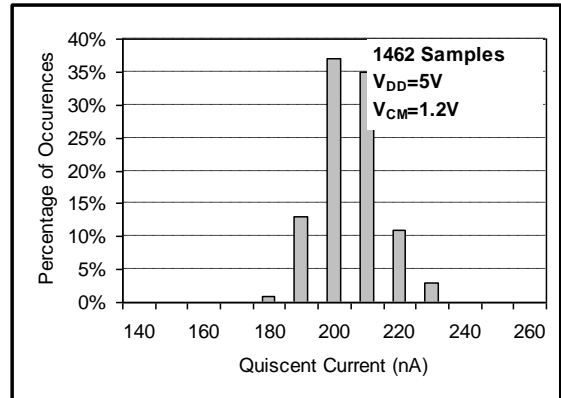

Low to High Propagation Delay Distribution

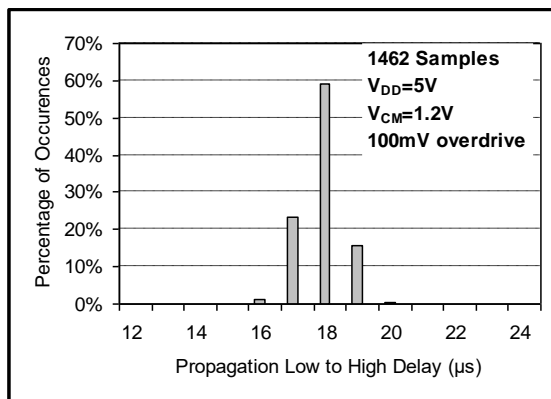

High to Low Propagation Delay Distribution

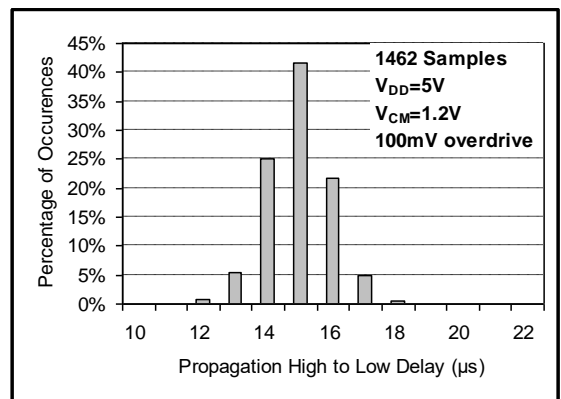

Typical Performance Characteristics

Propagation Delay Skew Distribution

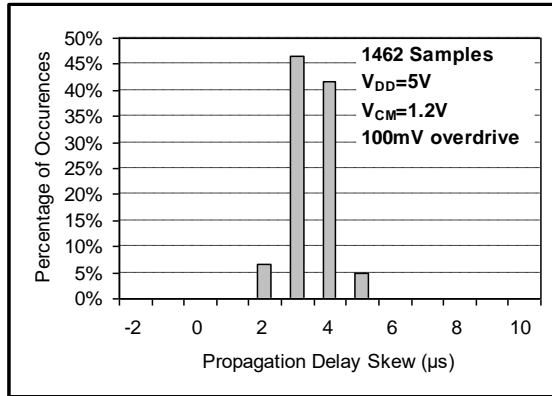

Output Voltage Headroom vs. Output Load Current

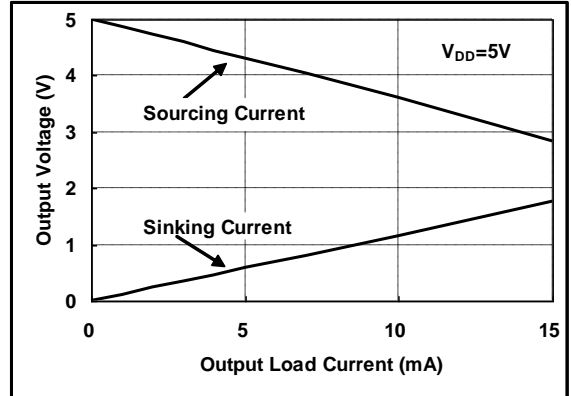

Output Voltage Headroom vs. Output Load Current

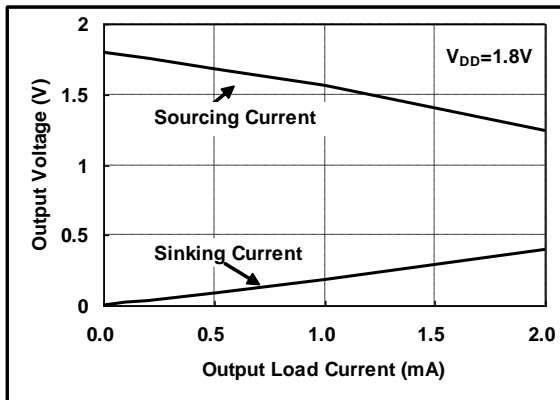

Output Voltage Headroom vs. Supply Voltage

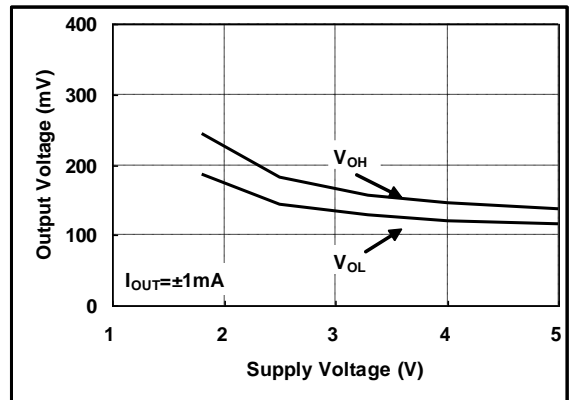

Output Short Current vs. Supply Voltage

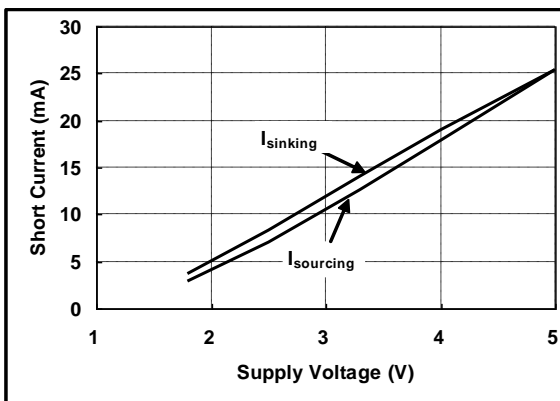

Operation

The TP201x family single-supply comparators feature internal hysteresis, high speed, and low power. Input signal range extends beyond the negative and positive power supplies. The output can even extend all the way to the negative supply. The input stage is active over different ranges of common mode input voltage. Rail-to-

rail input voltage range and low-voltage single-supply operation make these devices ideal for portable equipment.

Applications Information

Inputs

The TP201x comparator family uses CMOS transistors at the input which prevent phase inversion when the input pins exceed the supply voltages. Figure 1 shows an input voltage exceeding both supplies with no resulting phase inversion.

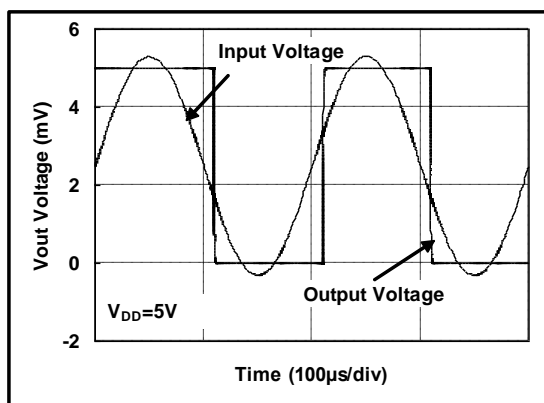

Figure 1. Comparator Response to Input Voltage

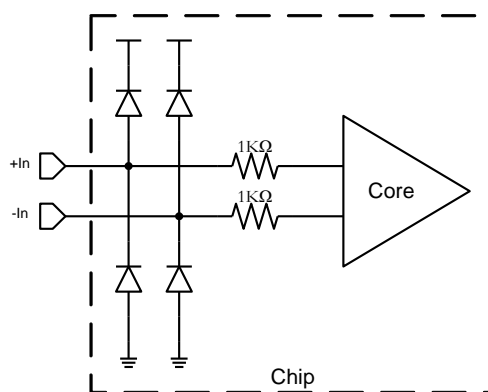

Figure 2. Equivalent Input Structure

The electrostatic discharge (ESD) protection input structure of two back-to-back diodes and 1kΩ series resistors are used to limit the differential input voltage applied to the precision input of the comparator by clamping input voltages that exceed supply voltages, as shown in Figure 2. Large differential voltages exceeding the supply voltage should be avoided to prevent damage to the input stage.

Internal Hysteresis

Most high-speed comparators oscillate in the linear region because of noise or undesired parasitic feedback. This tends to occur when the voltage on one input is at or equal to the voltage on the other input. To counter the parasitic effects and noise, the TP201x implements internal hysteresis.

The hysteresis in a comparator creates two trip points: one for the rising input voltage and one for the falling input voltage. The difference between the trip points is the hysteresis. When the comparator's input voltages are equal, the hysteresis effectively causes one comparator input voltage to move quickly past the other, thus taking the input out of the region where oscillation occurs. Figure 3 illustrates the case where IN- is fixed and IN+ is varied. If the inputs were reversed, the figure would look the same, except the output would be inverted.

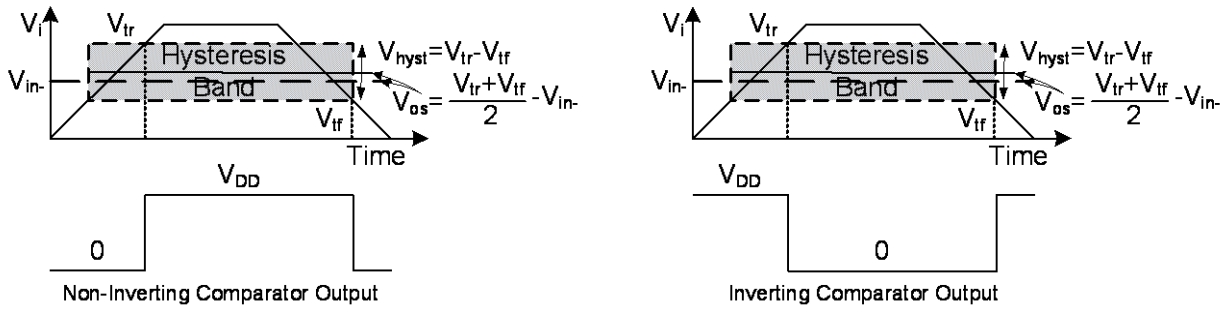

Figure 3. Comparator's hysteresis and offset

External Hysteresis

Greater flexibility in selecting hysteresis is achieved by using external resistors. Hysteresis reduces output chattering when one input is slowly moving past the other. It also helps in systems where it is best not to cycle between high and low states too frequently (e.g., air conditioner thermostatic control). Output chatter also increases the dynamic supply current.

Non-Inverting Comparator with Hysteresis

A non-inverting comparator with hysteresis requires a two-resistor network, as shown in Figure 4 and a voltage reference (V_r) at the inverting input.

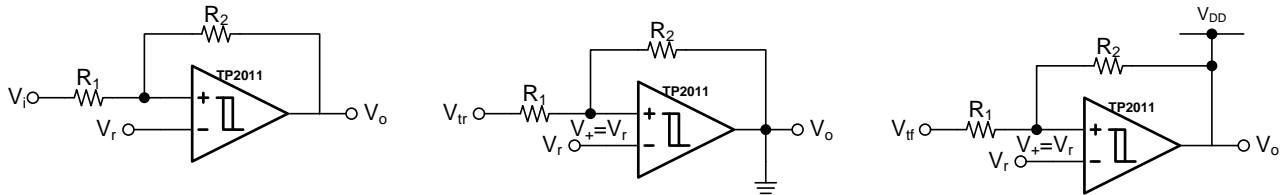

Figure 4. Non-Inverting Configuration with Hysteresis

When V_i is low, the output is also low. For the output to switch from low to high, V_i must rise up to V_{tr} . When V_i is high, the output is also high. In order for the comparator to switch back to a low state, V_i must equal V_{tf} before the non-inverting input V_+ is again equal to V_r .

$$V_r = \frac{R_2}{R_1 + R_2} V_{tr}$$

$$V_r = (V_{DD} - V_{tf}) \frac{R_1}{R_1 + R_2} + V_{tf}$$

$$V_{tr} = \frac{R_1 + R_2}{R_2} V_r$$

$$V_{tf} = \frac{R_1 + R_2}{R_2} V_r - \frac{R_1}{R_2} V_{DD}$$

$$V_{hyst} = V_{tr} - V_{tf} = \frac{R_1}{R_2} V_{DD}$$

Inverting Comparator with Hysteresis

The inverting comparator with hysteresis requires a three-resistor network that is referenced to the comparator supply voltage (V_{DD}), as shown in Figure 5.

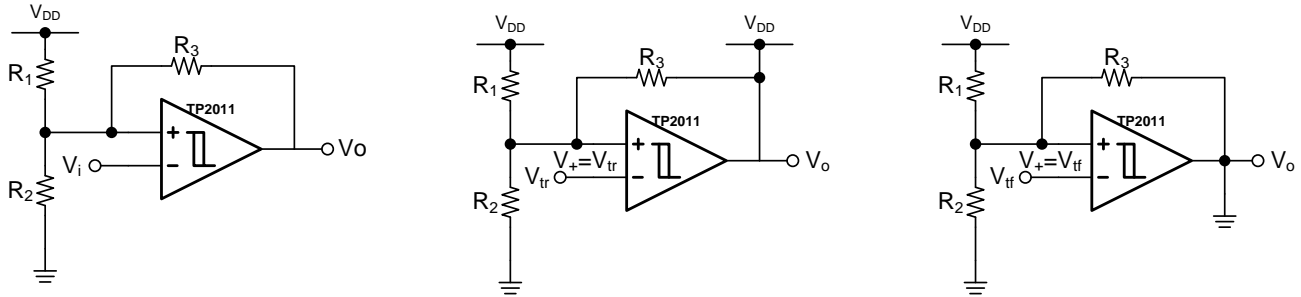

Figure 5. Inverting Configuration with Hysteresis

When V_i is greater than V_+ , the output voltage is low. In this case, the three network resistors can be presented as paralleled resistor $R_2 \parallel R_3$ in series with R_1 . When V_i at the inverting input is less than V_+ , the output voltage is high. The three network resistors can be represented as $R_1 \parallel R_3$ in series with R_2 .

$$V_{tr} = \frac{R_2}{R_1 \parallel R_3 + R_2} V_{DD}$$

$$V_{tf} = \frac{R_2 \parallel R_3}{R_2 \parallel R_3 + R_1} V_{DD}$$

$$V_{hyst} = V_{tr} - V_{tf} = \frac{R_1 \parallel R_2}{R_1 \parallel R_2 + R_3} V_{DD}$$

Low Input Bias Current

The TP201x family is a CMOS comparator family and features very low input bias current in pA range. The low input bias current allows the comparators to be used in applications with high resistance sources. Care must be taken to minimize PCB Surface Leakage. See below section on “PCB Surface Leakage” for more details.

PCB Surface Leakage

In applications where low input bias current is critical, Printed Circuit Board (PCB) surface leakage effects need to be considered. Surface leakage is caused by humidity, dust or other contamination on the board. Under low humidity conditions, a typical resistance between nearby traces is $10^{12}\Omega$. A 5V difference would cause 5pA of current to flow, which is greater than the TP201x’s input bias current at +27°C ($\pm 6\text{pA}$, typical). It is recommended to use multi-layer PCB layout and route the comparator’s -IN and +IN signal under the PCB surface.

The effective way to reduce surface leakage is to use a guard ring around sensitive pins (or traces). The guard ring is biased at the same voltage as the sensitive pin. An example of this type of layout is shown in Figure 6 for Inverting configuration application.

1. For Non-Inverting Configuration:

- a) Connect the non-inverting pin (V_{IN+}) to the input with a wire that does not touch the PCB surface.
- b) Connect the guard ring to the inverting input pin (V_{IN-}). This biases the guard ring to the same reference as the comparator.

2. For Inverting Configuration:

- a) Connect the guard ring to the non-inverting input pin (V_{IN+}). This biases the guard ring to the same reference voltage as the comparator (e.g., $V_{DD}/2$ or ground).
- b) Connect the inverting pin (V_{IN-}) to the input with a wire that does not touch the PCB surface.

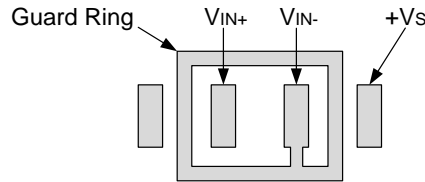

Figure 6. Example Guard Ring Layout for Inverting Comparator

Ground Sensing and Rail to Rail Output

The TP201x family implements a rail-to-rail topology that is capable of swinging to within 10mV of either rail. Since the inputs can go 300mV beyond either rail, the comparator can easily perform 'true ground' sensing.

The maximum output current is a function of total supply voltage. As the supply voltage of the comparator increases, the output current capability also increases. Attention must be paid to keep the junction temperature of the IC below 150°C when the output is in continuous short-circuit condition. The output of the amplifier has reverse-biased ESD diodes connected to each supply. The output should not be forced more than 0.5V beyond either supply, otherwise current will flow through these diodes.

ESD

The TP201x family has reverse-biased ESD protection diodes on all inputs and output. Input and output pins can not be biased more than 300mV beyond either supply rail.

Power Supply Layout and Bypass

The TP201x family's power supply pin should have a local bypass capacitor (i.e., 0.01 μ F to 0.1 μ F) within 2mm for good high frequency performance. It can also use a bulk capacitor (i.e., 1 μ F or larger) within 100mm to provide large, slow currents. This bulk capacitor can be shared with other analog parts.

Good ground layout improves performance by decreasing the amount of stray capacitance and noise at the comparator's inputs and outputs. To decrease stray capacitance, minimize PCB lengths and resistor leads, and place external components as close to the comparator's pins as possible.

Proper Board Layout

The TP201x family is a series of fast-switching, high-speed comparator and requires high-speed layout considerations. For best results, the following layout guidelines should be followed:

1. Use a printed circuit board (PCB) with a good, unbroken low-inductance ground plane.
2. Place a decoupling capacitor (0.1 μ F ceramic, surface-mount capacitor) as close as possible to supply.
3. On the inputs and the output, keep lead lengths as short as possible to avoid unwanted parasitic feedback around the comparator. Keep inputs away from the output.
4. Solder the device directly to the PCB rather than using a socket.
5. For slow-moving input signals, take care to prevent parasitic feedback. A small capacitor (1000 pF or less) placed between the inputs can help eliminate oscillations in the transition region. This capacitor causes some degradation to propagation delay when the impedance is low. The topside ground plane should be placed between the output and inputs.
6. The ground pin ground trace should run under the device up to the bypass capacitor, thus shielding the inputs from the outputs.

Typical Applications

IR Receiver

The TP2011 is an ideal candidate to be used as an infrared receiver shown in Figure 7. The infrared photo diode creates a current relative to the amount of infrared light present. The current creates a voltage across R_D . When this voltage level cross the voltage applied by the voltage divider to the inverting input, the output transitions. Optional R_o provides additional hysteresis for noise immunity.

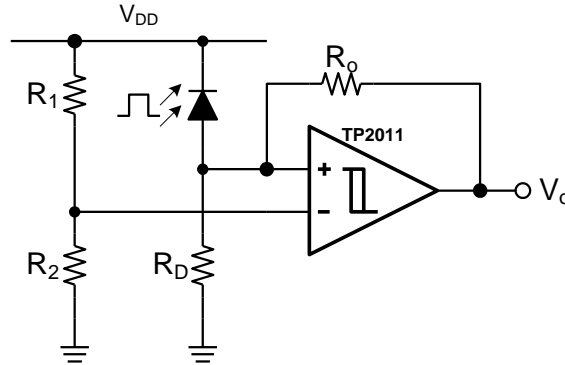

Figure 7. IR Receiver

Relaxation Oscillator

A relaxation oscillator using TP2011 is shown in Figure 8. Resistors R_1 and R_2 set the bias point at the comparator's inverting input. The period of oscillator is set by the time constant of R_4 and C_1 . The maximum frequency is limited by the large signal propagation delay of the comparator. TP2011's low propagation delay guarantees the high frequency oscillation.

If the inverted input (V_{C1}) is lower than the non-inverting input (V_A), the output is high which charges C_1 through R_4 until V_{C1} is equal to V_A . The value of V_A at this point is

$$V_{A1} = \frac{V_{DD} \cdot R_2}{R_1 \parallel R_3 + R_2}$$

At this point the comparator switches pulling down the output to the negative rail. The value of V_A at this point is

$$V_{A2} = \frac{V_{DD} \cdot R_2 \parallel R_3}{R_1 + R_2 \parallel R_3}$$

If $R_1=R_2=R_3$, then $V_{A1}=2V_{DD} /3$, and $V_{A2}= V_{DD}/3$

The capacitor C_1 now discharges through R_4 , and the voltage V_C decreases till it is equal to V_{A2} , at which point the comparator switches again, bringing it back to the initial stage. The time period is equal to twice the time it takes to discharge C_1 from $2V_{DD}/3$ to $V_{DD}/3$. Hence the frequency is:

$$\text{Freq} = \frac{1}{2 \cdot \ln 2 \cdot R_4 \cdot C_1}$$

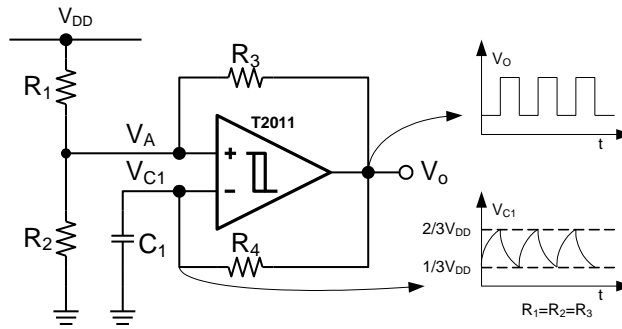

Figure 8. Relaxation Oscillator

Windowed Comparator

Figure 9. shows one approach to designing a windowed comparator using a single TP2012 chip. Choose different thresholds by changing the values of R1, R2, and R3. OutA provides an active-low undervoltage indication, and OutB gives an active-low overvoltage indication. ANDing the two outputs provides an active-high, power-good signal. When input voltage Vi reaches the overvoltage threshold VOH, the OutB gets low. Once Vi falls to the undervoltage threshold VUH, the OutA gets low. When VUH < Vi < VOH, the AND Gate gets high.

$$V_{OH} = V_r \cdot (R_1 + R_2 + R_3) / R_1$$

$$V_{UH} = V_r \cdot (R_1 + R_2 + R_3) / (R_1 + R_2)$$

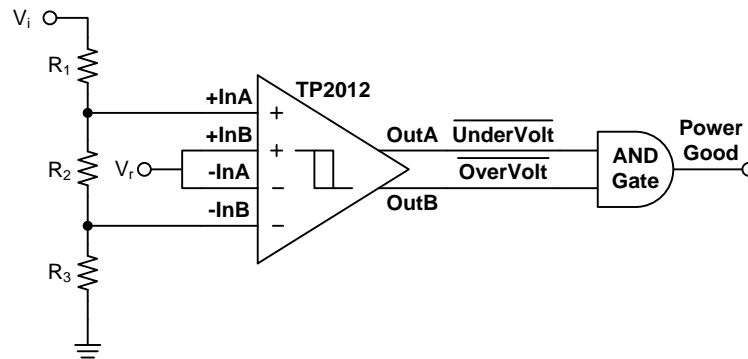

Figure 9. Windowed Comparator

Higher Vcm input range

When VDD is 2.2 or higher under 75°C, Vcm could be as high as 1.3V.

Package Outline Dimensions

SOT353 (SC70-5)

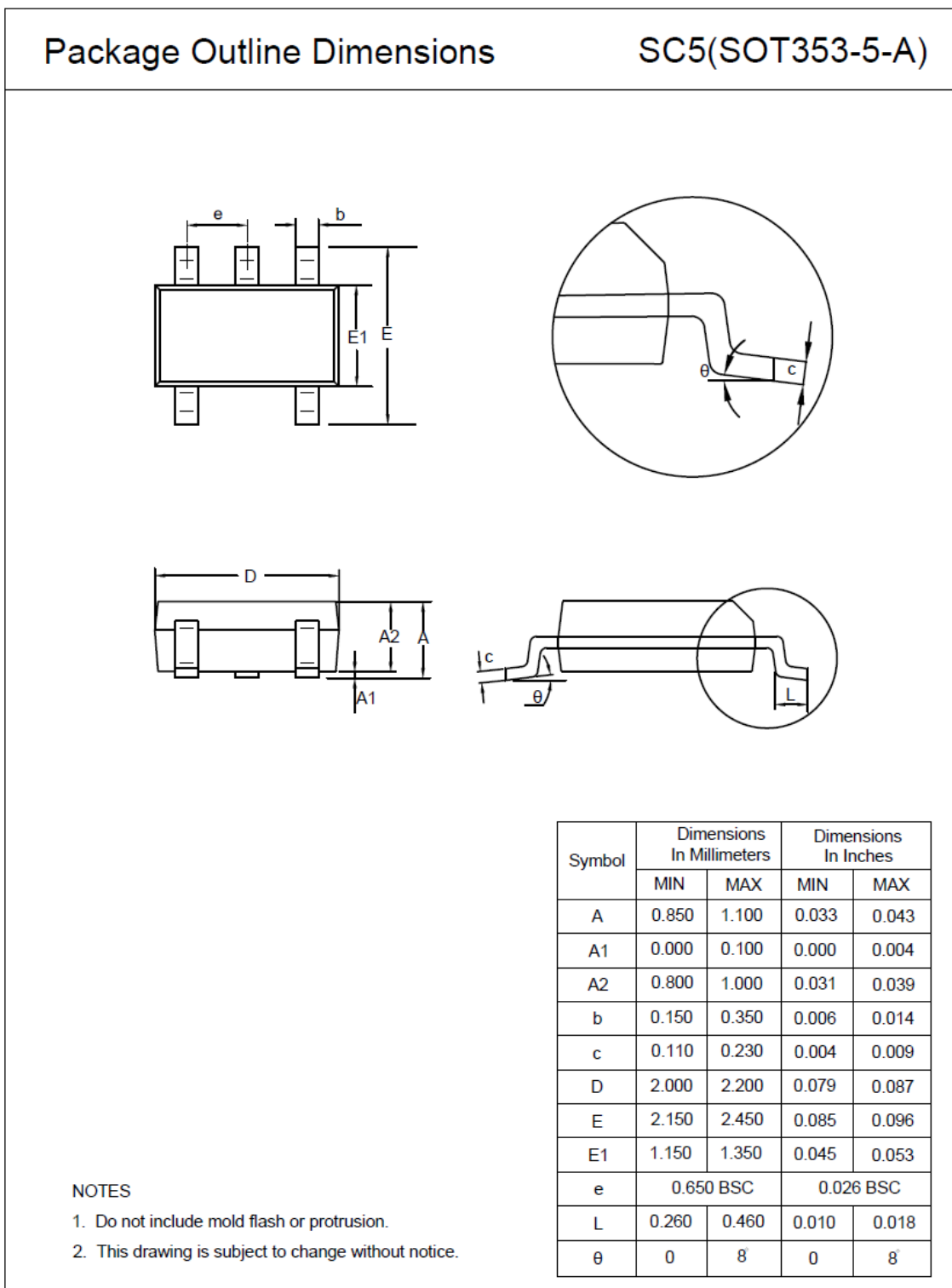

SOT23-5

Package Outline Dimensions

S5T(SOT23-5-A)

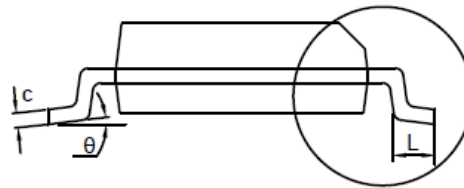
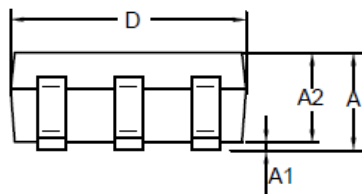
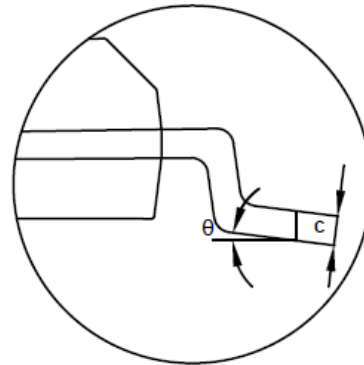
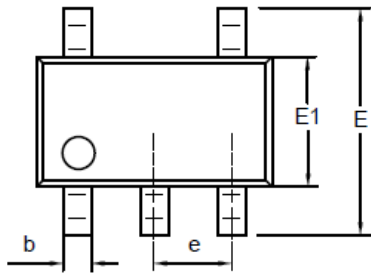

Symbol	Dimensions In Millimeters		Dimensions In Inches	
	MIN	MAX	MIN	MAX
A	1.050	1.250	0.041	0.049
A1	0.000	0.150	0.000	0.006
A2	1.000	1.200	0.039	0.047
b	0.280	0.500	0.011	0.020
c	0.100	0.230	0.004	0.009
D	2.820	3.020	0.111	0.119
E	2.600	3.000	0.102	0.118
E1	1.500	1.720	0.059	0.068
e	0.950 BSC		0.037 BSC	
L	0.300	0.600	0.012	0.024
θ	0	8°	0	8°

NOTES

1. Do not include mold flash or protrusion.
2. This drawing is subject to change without notice.

SOP8

Package Outline Dimensions

SO1(SOP-8-A)

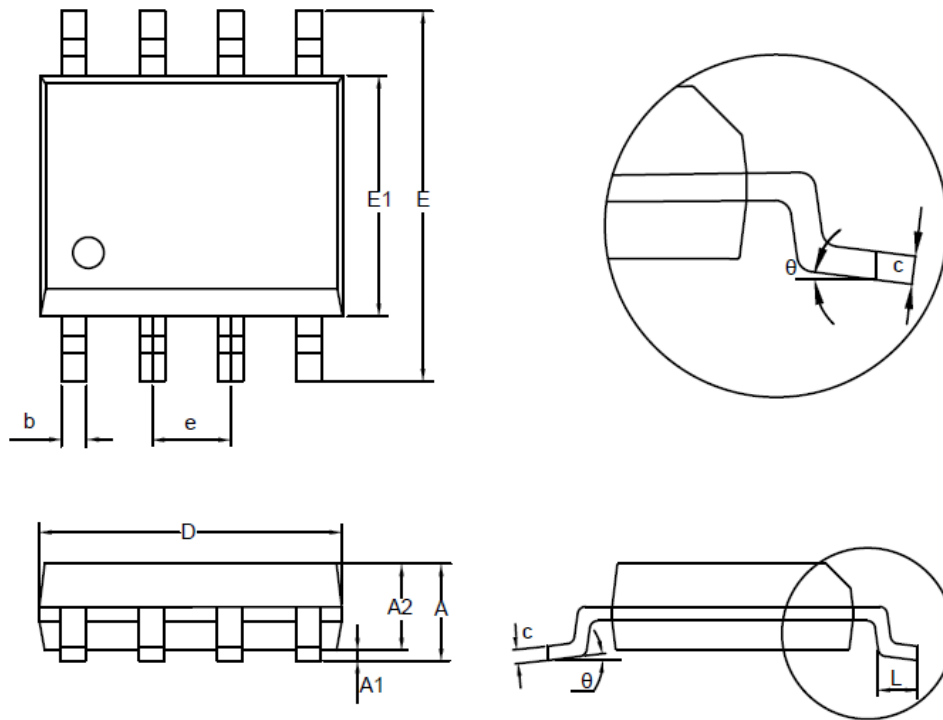

Symbol	Dimensions In Millimeters		Dimensions In Inches	
	MIN	MAX	MIN	MAX
A	1.350	1.750	0.053	0.069
A1	0.050	0.250	0.002	0.010
A2	1.250	1.550	0.049	0.061
b	0.330	0.510	0.013	0.020
c	0.170	0.250	0.007	0.010
D	4.700	5.100	0.185	0.201
E	5.800	6.200	0.228	0.244
E1	3.800	4.000	0.150	0.157
e	1.270 BSC		0.050 BSC	
L	0.400	1.000	0.016	0.039
θ	0	8°	0	8°

NOTES

1. Do not include mold flash or protrusion.
2. This drawing is subject to change without notice.

Package Outline Dimensions

MSOP-8

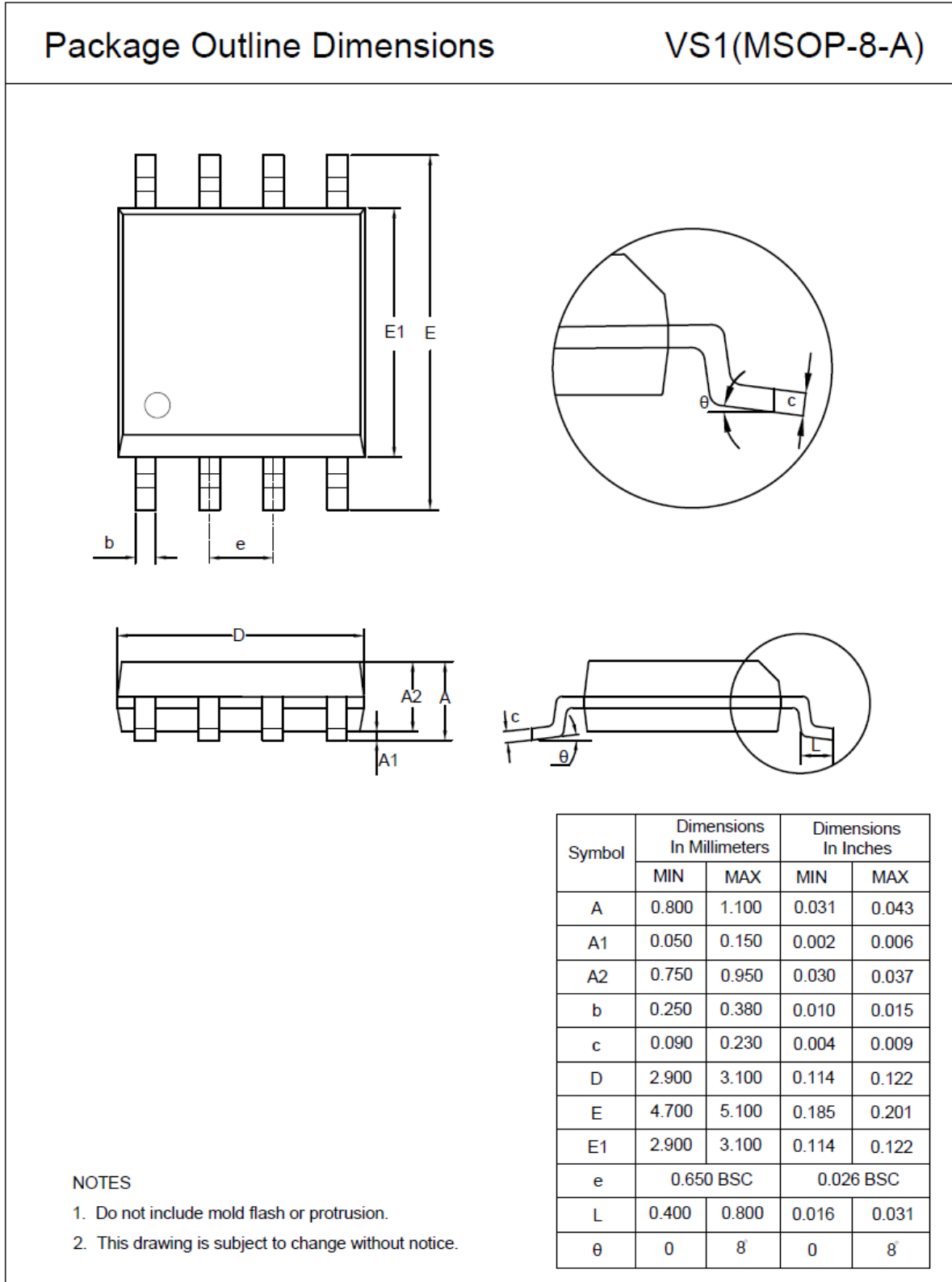

Revision History

Date	Revision	Notes
2022/4/28	1.9	Updated order information
2023/10/19	1.10.Pre	Updated the max of supply voltage from 5.5V to 6V, updated the absolute maximum ratings of supply voltage from 6V to 6.5V. The following updates are all about the new datasheet formats or typo, the actual product remains unchanged. Updated to new format of package dimensions.

IMPORTANT NOTICE AND DISCLAIMER

Copyright© 3PEAK 2012-2023. All rights reserved.

Trademarks. Any of the 思瑞浦 or 3PEAK trade names, trademarks, graphic marks, and domain names contained in this document /material are the property of 3PEAK. You may NOT reproduce, modify, publish, transmit or distribute any Trademark without the prior written consent of 3PEAK.

Performance Information. Performance tests or performance range contained in this document/material are either results of design simulation or actual tests conducted under designated testing environment. Any variation in testing environment or simulation environment, including but not limited to testing method, testing process or testing temperature, may affect actual performance of the product.

Disclaimer. 3PEAK provides technical and reliability data (including data sheets), design resources (including reference designs), application or other design recommendations, networking tools, security information and other resources "As Is". 3PEAK makes no warranty as to the absence of defects, and makes no warranties of any kind, express or implied, including without limitation, implied warranties as to merchantability, fitness for a particular purpose or non-infringement of any third-party's intellectual property rights. Unless otherwise specified in writing, products supplied by 3PEAK are not designed to be used in any life-threatening scenarios, including critical medical applications, automotive safety-critical systems, aviation, aerospace, or any situations where failure could result in bodily harm, loss of life, or significant property damage. 3PEAK disclaims all liability for any such unauthorized use.