

Features

- Wide Supply Voltage Range from 1.65 V to 5.5 V
- I/O Tolerance Inputs to 5.5 V
- All Inputs with Schmitt-Trigger Input
- CMOS Low Power Dissipation
- I_{OFF} Supports Partial Power-down Protection
- ESD Protection: ±4-kV HBM Model, ±1-kV CDM Model
- Latch-up Performance Exceeds 100 mA per JESD 78, Class II
- AEC-Q100 Qualified for Automotive Applications, Grade 1

Applications

- Automotive Body Electronics

Description

The T74L2G14Q is a dual Schmitt-Trigger inverter with V_{CC} supply from 1.65 V to 5.5 V. Schmitt-Trigger input with slower rise-and-fall times and better noise immunity. I_{OFF} circuits can prevent backflow current during power-down, thus supporting partial power-down protection.

The T74L2G14Q is available in the SOT363 package and is AEC-Q100 qualified for automotive applications.

Device Table

Device	Package	Body Size
T74L2G14Q-SC6R-S	SOT363	2.1 mm x 1.25 mm

Typical Application Circuit

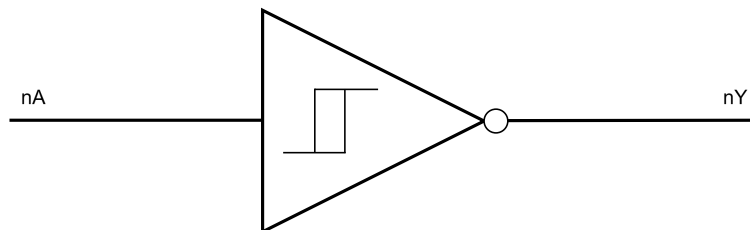

Table of Contents

Features	1
Applications	1
Description	1
Device Table	1
Typical Application Circuit	1
Revision History	3
Pin Configuration and Functions	4
Specifications	5
Absolute Maximum Ratings ⁽¹⁾	5
ESD, Electrostatic Discharge Protection.....	5
Recommended Operating Conditions.....	5
Thermal Information.....	6
Electrical Characteristics – DC Parameter.....	7
Electrical Characteristics – AC Parameter.....	8
Parameter Measurement Waveforms.....	9
Application and Implementation	10
Typical Application.....	10
Tape and Reel Information	11
Package Outline Dimensions	12
SOT363.....	12
Land Pattern	13
SOT363.....	13
Order Information	14
IMPORTANT NOTICE AND DISCLAIMER	15

Revision History

Date	Revision	Notes
2025-04-17	Rev.Pre.0	Initial version.
2026-01-21	Rev.A.0	Released version.

Pin Configuration and Functions

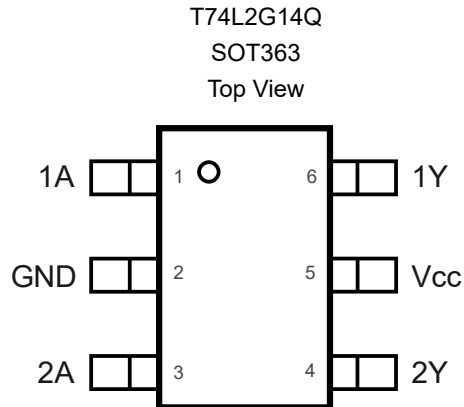

Table 1. Pin Functions

Pin No.	Name	I/O	Description
1	1A	I	Input 1A
2	GND	Power	Ground
3	2A	I	Input 2A
4	2Y	O	Output 2Y
5	V _{CC}	Power	Supply pin
6	1Y	O	Output 1Y

Function Table

Table 2. Truth Table

Input	Output
nA	nY
L	H
H	L

(1) H = High voltage level.

(2) L = Low voltage level.

(3) X = Don't care.

Specifications

Absolute Maximum Ratings ⁽¹⁾

Parameter		Min	Max	Unit
V _{CC}	Supply Voltage	-0.5	6.5	V
V _I	Input Voltage ⁽²⁾	-0.5	6.5	V
V _O	Output Voltage, in Power-off Mode ⁽²⁾	-0.5	6.5	V
V _O	Output Voltage, in Active Mode ⁽²⁾	-0.5	V _{CC} + 0.5	V
I _O	Continuous Output Current	-50	50	mA
I _{IK}	Input Clamp Current, V _I < 0	-50		mA
I _{OK}	Output Clamp Current, V _O < 0	-50		mA
	Continuous Current through V _{CC} or GND	-100	100	mA
T _J	Junction Temperature		150	°C
T _{STG}	Storage Temperature	-65	150	°C

(1) Stresses beyond those listed under Absolute Maximum Ratings may cause permanent damage to the device. These are stress ratings only, which do not imply functional operation of the device at these or any other conditions beyond those indicated under Recommended Operating Conditions. Exposure to absolute-maximum-rated conditions for extended periods may affect device reliability.

(2) The minimum input and output voltage ratings may be exceeded if the input and output current ratings are observed.

ESD, Electrostatic Discharge Protection

Symbol	Parameter	Condition	Minimum Level	Unit
HBM	Human Body Model ESD	AEC Q100-002, all pins ⁽¹⁾	±4,000	V
CDM	Charged Device Model ESD	AEC Q100-011, all pins	±1,000	V

(1) AEC Q100-002 indicates that HBM stress should conform to the ANSI/ESDA/JEDEC JS-001 specification.

Recommended Operating Conditions

All unused inputs of the device must be held at V_{CC} or GND to ensure proper device operation.

Parameter		Min	Typ	Max	Unit
V _{CC}	Supply Voltage	1.65		5.5	V
V _I	Input Voltage	0		5.5	V
V _O	Output Voltage	0		V _{CC}	V
T _A	Ambient Temperature	-40		125	°C

Thermal Information

Package Type	θ_{JA}	θ_{JC}	Unit
SOT363	230.1	62.7	°C/W

Automotive Dual Schmitt-Trigger Inverter
Electrical Characteristics – DC Parameter

All test conditions: $T_A = -40^{\circ}\text{C}$ to 125°C , all typical values are measured at $T_A = 25^{\circ}\text{C}$, unless otherwise noted.

Symbol	Parameter	Conditions	Min	Typ	Max	Unit
V_{IH}	High-Level Input Voltage	$V_{CC} = 1.8\text{ V}$	1.26			V
		$V_{CC} = 2.3\text{ V}$	1.4			V
		$V_{CC} = 3\text{ V}$	1.71			V
		$V_{CC} = 4.5\text{ V}$	2.36			V
		$V_{CC} = 5.5\text{ V}$	2.79			V
V_{IL}	Low-Level Input Voltage	$V_{CC} = 1.8\text{ V}$			0.46	V
		$V_{CC} = 2.3\text{ V}$			0.65	V
		$V_{CC} = 3\text{ V}$			0.88	V
		$V_{CC} = 4.5\text{ V}$			1.32	V
		$V_{CC} = 5.5\text{ V}$			1.58	V
V_{OH}	High-Level Output Voltage	$I_{OH} = -100\ \mu\text{A}$; $V_{CC} = 1.65\text{ V to }5.5\text{ V}$	$V_{CC} - 0.1$			V
		$I_{OH} = -4\text{ mA}$; $V_{CC} = 1.65\text{ V}$	0.95			V
		$I_{OH} = -8\text{ mA}$; $V_{CC} = 2.3\text{ V}$	1.7			V
		$I_{OH} = -12\text{ mA}$; $V_{CC} = 2.7\text{ V}$	1.9			V
		$I_{OH} = -24\text{ mA}$; $V_{CC} = 3\text{ V}$	2			V
		$I_{OH} = -32\text{ mA}$; $V_{CC} = 4.5\text{ V}$	3.4			V
V_{OL}	Low-Level Output Voltage	$I_{OL} = 100\ \mu\text{A}$; $V_{CC} = 1.65\text{ V to }5.5\text{ V}$			0.1	V
		$I_{OL} = 4\text{ mA}$; $V_{CC} = 1.65\text{ V}$			0.7	V
		$I_{OL} = 8\text{ mA}$; $V_{CC} = 2.3\text{ V}$			0.45	V
		$I_{OL} = 12\text{ mA}$; $V_{CC} = 2.7\text{ V}$			0.6	V
		$I_{OL} = 24\text{ mA}$; $V_{CC} = 3\text{ V}$			0.8	V
		$I_{OL} = 32\text{ mA}$; $V_{CC} = 4.5\text{ V}$			0.8	V
I_I	Input Leakage Current	$V_I = \text{GND or }5.5\text{ V}$; $V_{CC} = 0\text{ V to }5.5\text{ V}$	-1	± 0.1	1	μA
I_{OFF}	Power-off Leakage Current	V_I or $V_O = 5.5\text{ V}$; $V_{CC} = 0\text{ V}$	-1	± 0.1	1	μA
I_{CC}	Supply Current	$V_I = \text{GND or }V_{CC}$; $I_O = 0\text{ A}$; $V_{CC} = 1.65\text{ V to }5.5\text{ V}$		0.1	2	μA
ΔI_{CC}	Additional Supply Current	$V_I = V_{CC} - 0.6\text{ V}$; $I_O = 0\text{ A}$; $V_{CC} = 2.3\text{ V to }5.5\text{ V}$		0.1	10	μA
$C_i^{(1)}$	Input Capacitance			2.1		pF

(1) Spec limit is based on bench characterization and design simulation, not tested in production.

Electrical Characteristics – AC Parameter

All test conditions: $T_A = -40^{\circ}\text{C}$ to 125°C , all typical values are measured at $T_A = 25^{\circ}\text{C}$, unless otherwise noted.

Symbol ⁽¹⁾	Parameter	Conditions	Min	Typ	Max	Unit
t_{PD} ⁽²⁾	Propagation Delay at 30-pF C_{LOAD}	$C_{LOAD} = 30\text{ pF};$ $V_{CC} = 1.65\text{ V to }1.95\text{ V}$	3.2	8.8	15	ns
		$C_{LOAD} = 30\text{ pF};$ $V_{CC} = 2.3\text{ V to }2.7\text{ V}$	2	5.5	8.9	ns
	Propagation Delay at 50-pF C_{LOAD}	$C_{LOAD} = 50\text{ pF};$ $V_{CC} = 2.7\text{ V}$	2.3	5.4	8.3	ns
		$C_{LOAD} = 50\text{ pF};$ $V_{CC} = 3\text{ V to }3.6\text{ V}$	1.9	4.6	7.6	ns
		$C_{LOAD} = 50\text{ pF};$ $V_{CC} = 4.5\text{ V to }5.5\text{ V}$	1.6	3.6	6	ns
	C_{PD} ⁽³⁾	Power Dissipation Capacitance	$f = 10\text{ MHz};$ $V_{CC} = 3.3\text{ V}$		13	

(1) Spec limit is based on bench characterization and design simulation, not tested in production.

(2) t_{PD} is the same as t_{PLH} and t_{PHL} .

(3) C_{PD} is used to determine the dynamic power dissipation (PD in μW).

$$P_D = C_{PD} \times V_{CC}^2 \times f_i \times N + \Sigma(C_L \times V_{CC}^2 \times f_o)$$

Where:

f_i = Input frequency in MHz;

f_o = Output frequency in MHz;

C_L = Output load capacitance in pF;

V_{CC} = Supply voltage in Volts;

N = Number of inputs switching;

$\Sigma(C_L \times V_{CC}^2 \times f_o)$ = Sum of the outputs.

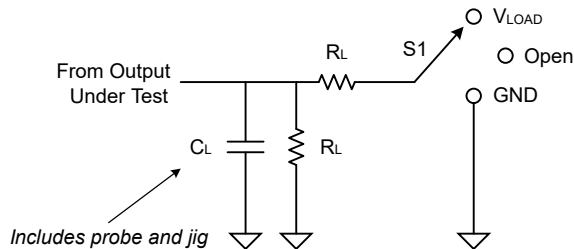
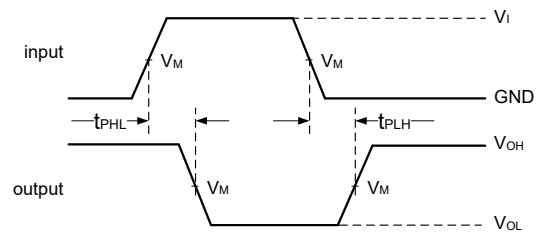
Parameter Measurement Waveforms

Figure 1. Timing Measurement Load Circuit

Figure 2. Propagation Delay Times
Table 3. Test Data

V _{CC}	Inputs		C _L	R _L	V _M	S1
	V _I	t _r /t _f				t _{PHL} /t _{PLH}
1.65 V to 1.95 V	V _{CC}	≤ 2 ns	30 pF	1 kΩ	0.5V _{CC}	Open
2.3 V to 2.7 V	V _{CC}	≤ 2 ns	30 pF	500 Ω	0.5V _{CC}	Open
2.7 V	2.7 V	≤ 2.5 ns	50 pF	500 Ω	1.5 V	Open
3 V to 3.6 V	2.7 V	≤ 2.5 ns	50 pF	500 Ω	1.5 V	Open
4.5 V to 5.5 V	V _{CC}	≤ 2.5 ns	50 pF	500 Ω	0.5V _{CC}	Open

Application and Implementation

Note

Information in the following application sections is not part of the 3PEAK's component specification and 3PEAK does not warrant its accuracy or completeness. 3PEAK's customers are responsible for determining suitability of components for their purposes. Customers should validate and test their design implementation to confirm system functionality.

Typical Application

Figure 3 shows the typical application schematic.

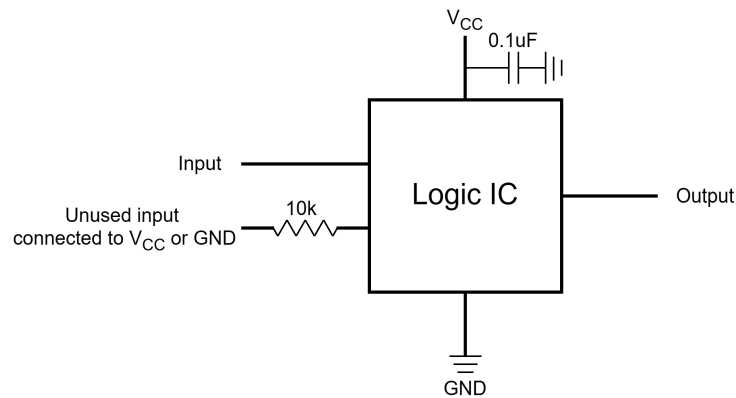
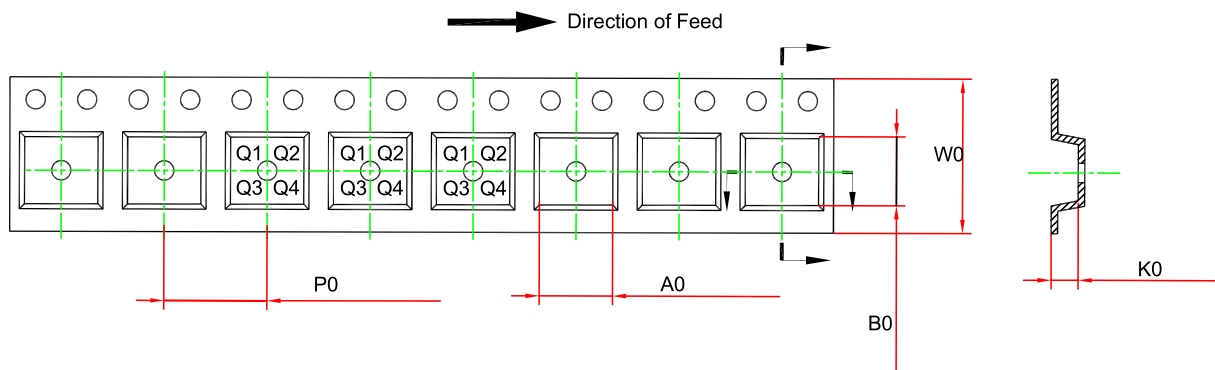
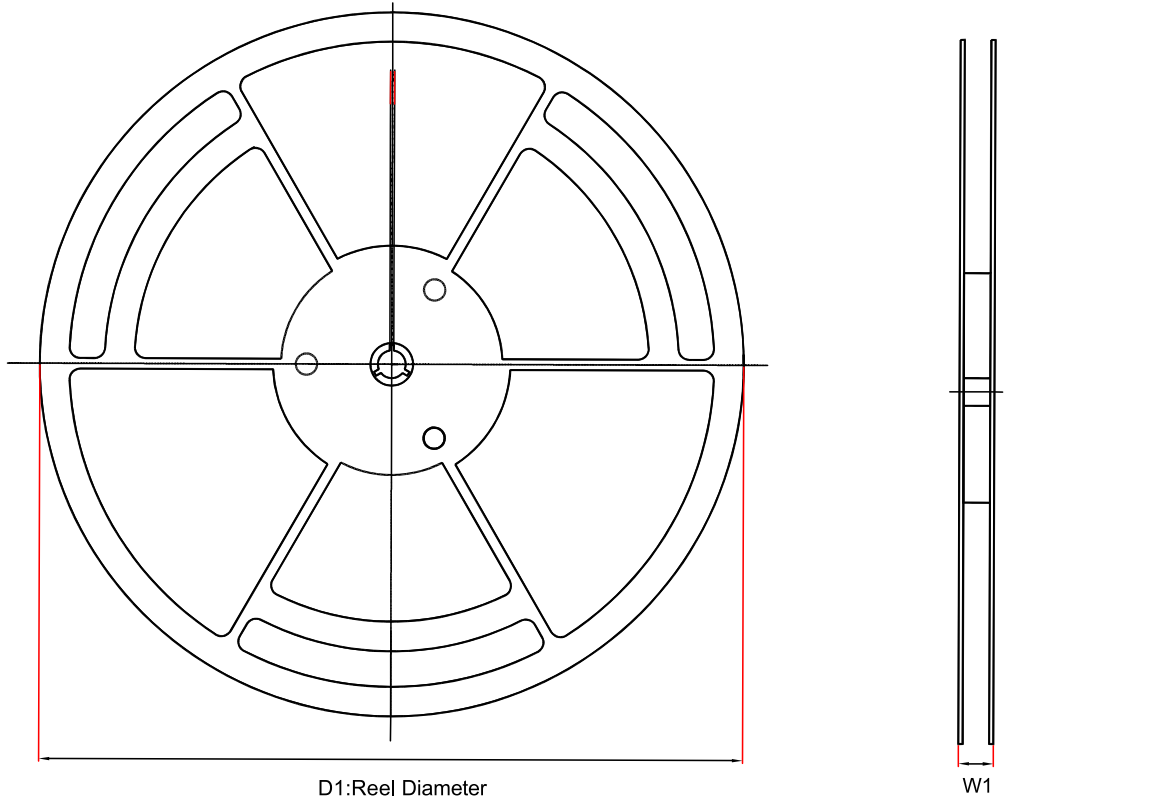

Figure 3. Typical Application Circuit

Tape and Reel Information

Order Number	Package	D1 (mm)	W1 (mm)	A0 (mm)	B0 (mm)	K0 (mm)	P0 (mm)	W0 (mm)	Pin1 Quadrant
T74L2G14Q-SC6R-S	SOT363	178	12.1	2.4	2.5	1.2	4	8	Q3

Package Outline Dimensions

SOT363

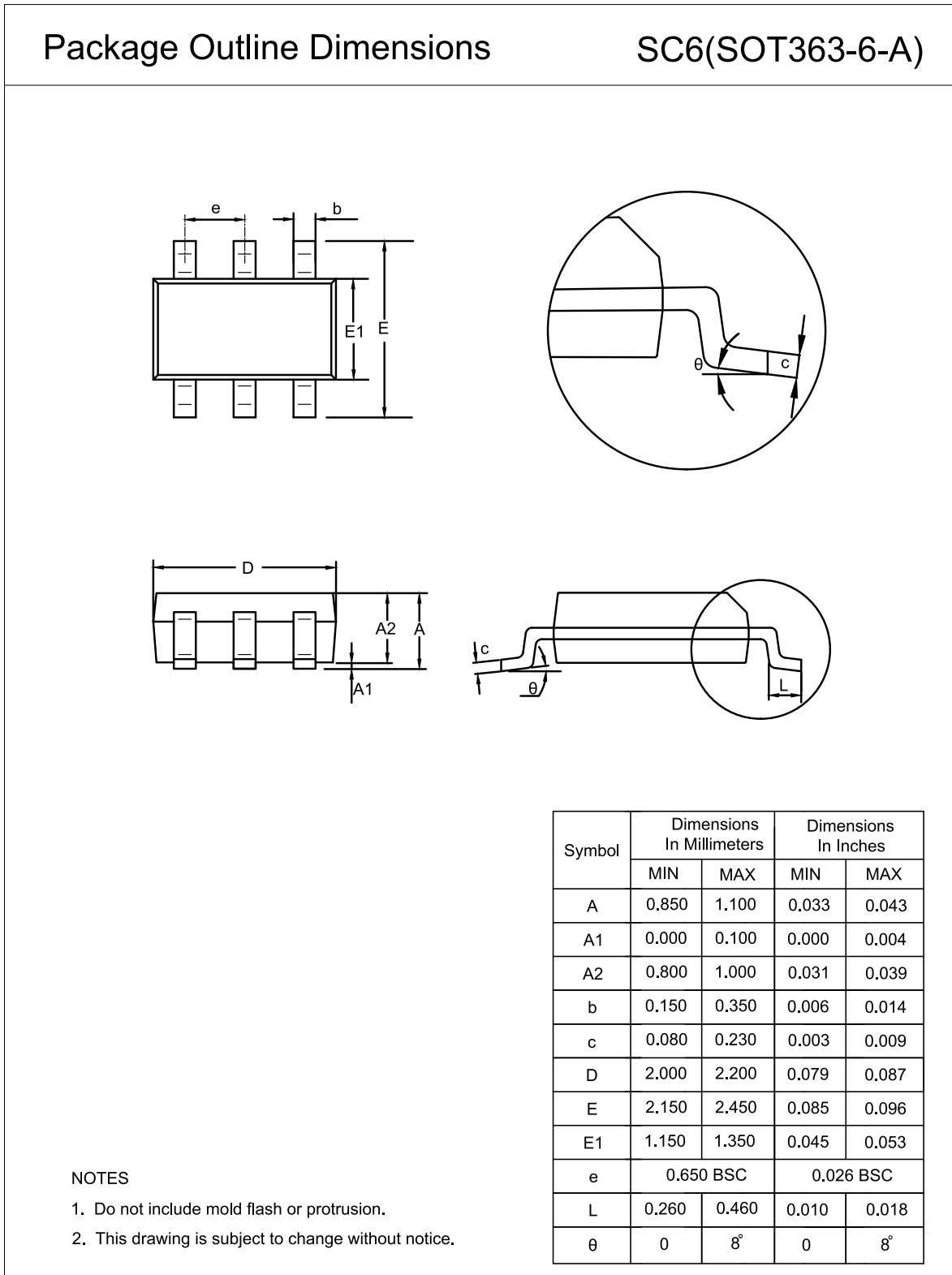

Land Pattern

SOT363

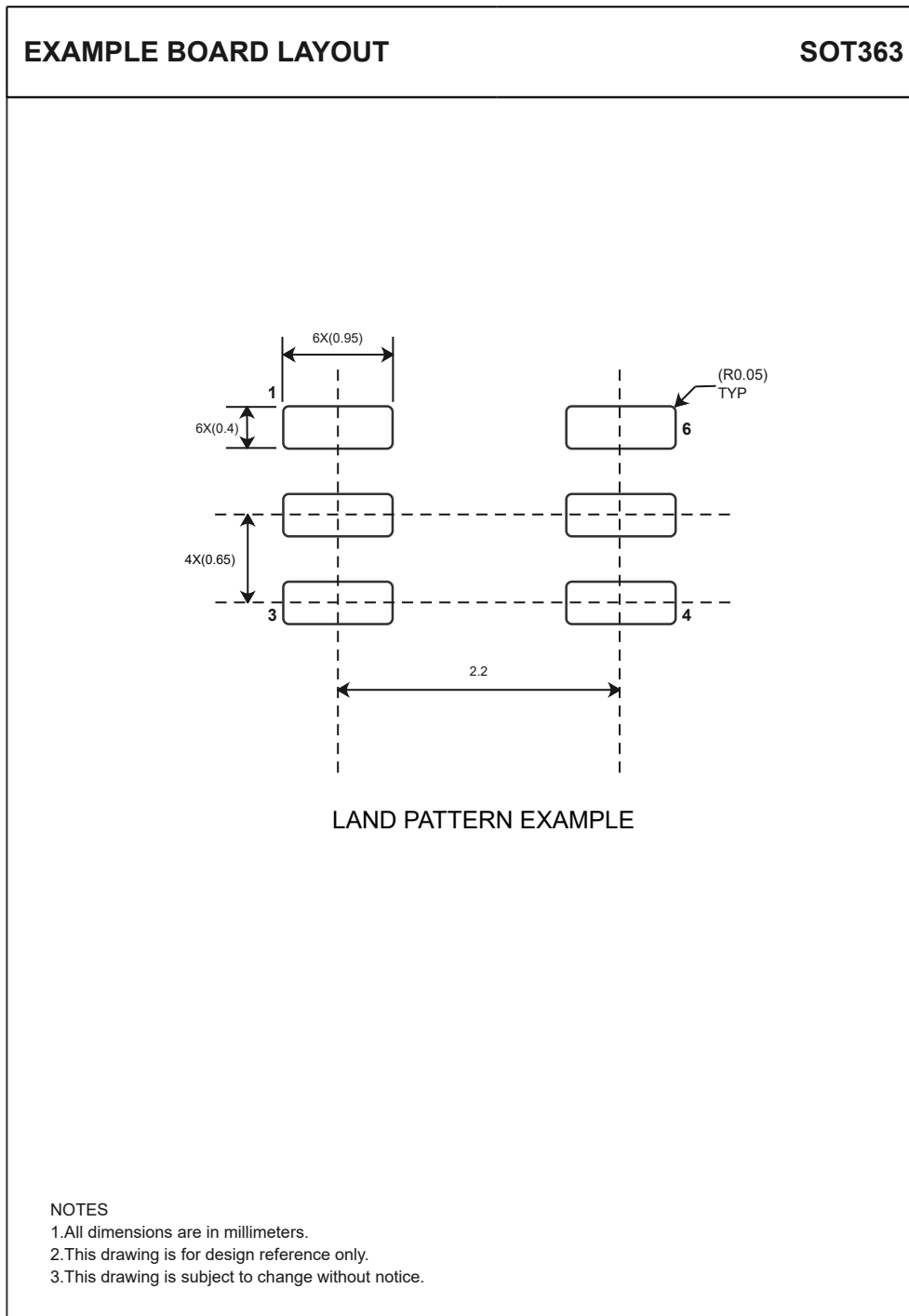

Order Information

Order Number	Operating Temperature Range	Package	Marking Information	MSL	Transport Media, Quantity	Eco Plan
T74L2G14Q-SC6R-S	-40 to 125°C	SOT363	VK	MSL1	Tape and Reel,3000	Green

Green: 3PEAK defines "Green" to mean RoHS compatible and free of halogen substances.

IMPORTANT NOTICE AND DISCLAIMER

Copyright© 3PEAK 2012-2026. All rights reserved.

Trademarks. Any of the 思瑞浦 or 3PEAK trade names, trademarks, graphic marks, and domain names contained in this document /material are the property of 3PEAK. You may NOT reproduce, modify, publish, transmit or distribute any Trademark without the prior written consent of 3PEAK.

Performance Information. Performance tests or performance range contained in this document/material are either results of design simulation or actual tests conducted under designated testing environment. Any variation in testing environment or simulation environment, including but not limited to testing method, testing process or testing temperature, may affect actual performance of the product.

Disclaimer. 3PEAK provides technical and reliability data (including data sheets), design resources (including reference designs), application or other design recommendations, networking tools, security information and other resources "As Is". 3PEAK makes no warranty as to the absence of defects, and makes no warranties of any kind, express or implied, including without limitation, implied warranties as to merchantability, fitness for a particular purpose or non-infringement of any third-party's intellectual property rights. Unless otherwise specified in writing, products supplied by 3PEAK are not designed to be used in any life-threatening scenarios, including critical medical applications, automotive safety-critical systems, aviation, aerospace, or any situations where failure could result in bodily harm, loss of life, or significant property damage. 3PEAK disclaims all liability for any such unauthorized use.

This page intentionally left blank